

MULTI V™



LG HVAC SOLUTION
MULTI V™

For Middle East & Africa



LG Electronics

<http://www.lg.com>
<http://partner.lge.com>

Distributed by

 LG | Business Solutions

INDEX



OUTDOOR UNITS

018 - 135

MULTI V 5	022
MULTI V S	086
MULTI V M	104
MULTI V WATER IV (HEAT PUMP / HEAT RECOVERY)	114

INDOOR UNITS

136 - 213

WALL MOUNTED UNIT	140
ROUND CASSETTE	154
CEILING MOUNTED CASSETTE	158
CEILING CONCEALED DUCT	176
FRESH AIR INTAKE UNIT	190
FLOOR STANDING UNIT	192
CEILING SUSPENDED UNIT	196
CONSOLE & FLOOR STANDING UNIT	202
COMPATIBILITY	210
FEATURE FUNCTIONS	213

HOT WATER SOLUTION

214 - 221

HYDRO KIT	216
-----------	-----

VENTILATION SOLUTIONS

222 - 237

ERV	224
ERV WITH DX COIL	236

CONTROL SOLUTIONS

238 - 293

INDIVIDUAL CONTROL	244
CENTRALIZED CONTROL	254
INTEGRATION DEVICE	266

ACCESSORIES

294 - 315

MECHANICAL ACCESSORIES	296
PIPING ACCESSORIES	304

LG Air Solution Production Sites

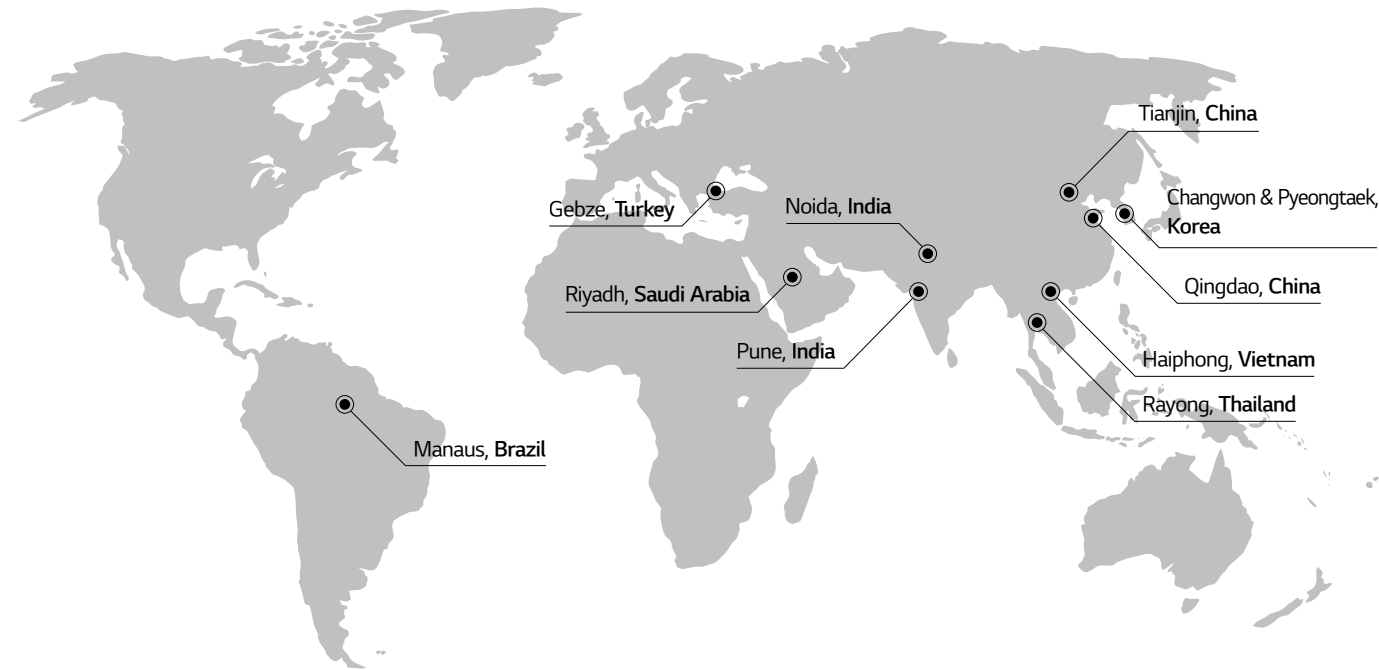

The LG Electronics Air Solution Business Unit is a provider of total HVAC and energy solution. The company offers a broad portfolio of air conditioner products that are compatible with any building anywhere, including compact residences, towering skyscrapers, massive factories and giant concert halls.

As a true total HVAC and energy solution provider, LG also supplies even the largest buildings and industrial facilities with central air conditioning systems such as chillers and efficient control solutions.

The history of the business unit goes back to 1968, when LG (then called GoldStar) rolled out Korea's first residential air conditioner.

As the company first began making chillers for large commercial buildings in 1970, the commercial air conditioning business has grown exponentially, especially within the last 20 years.

In 2008, LG sold its 100 millionth air conditioning unit, becoming the first company in the industry to reach that significant milestone.

The success of LG air conditioners has allowed the company to become one of the major players in the highly competitive HVAC industry.

By enhancing the industry's B2B infrastructure and finding further solutions for the HVAC sector, LG has risen to become a total HVAC solutions specialist.

The company has steadily increased its sales and market share by introducing energy efficient and reliable HVAC solutions and actively pursuing new opportunities wherever they arise.

This sustained, excellent performance is built on a solid foundation of global R&D and advanced manufacturing capabilities.

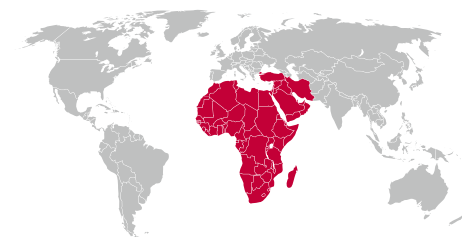
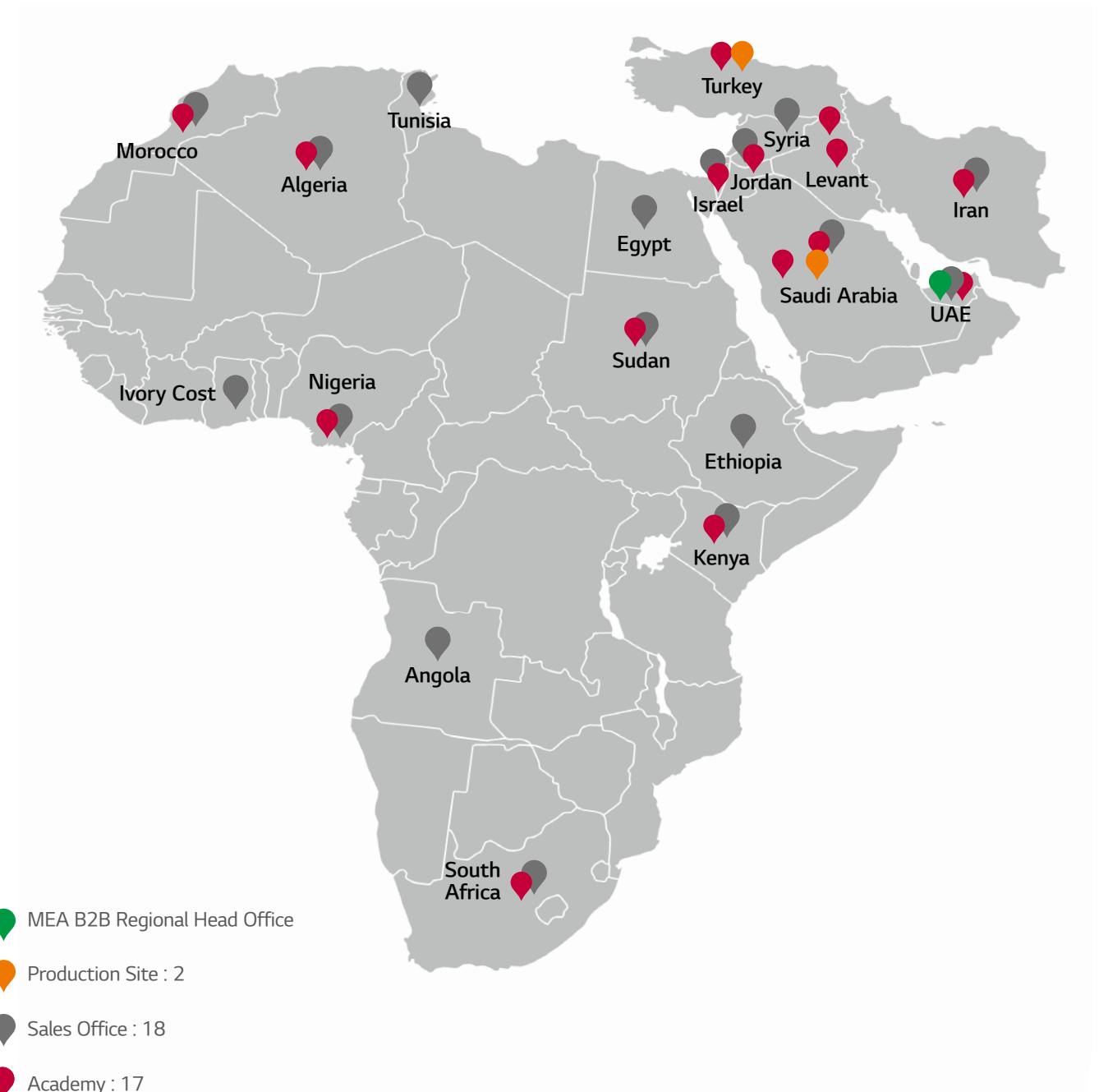

MULTI V BRAND HISTORY

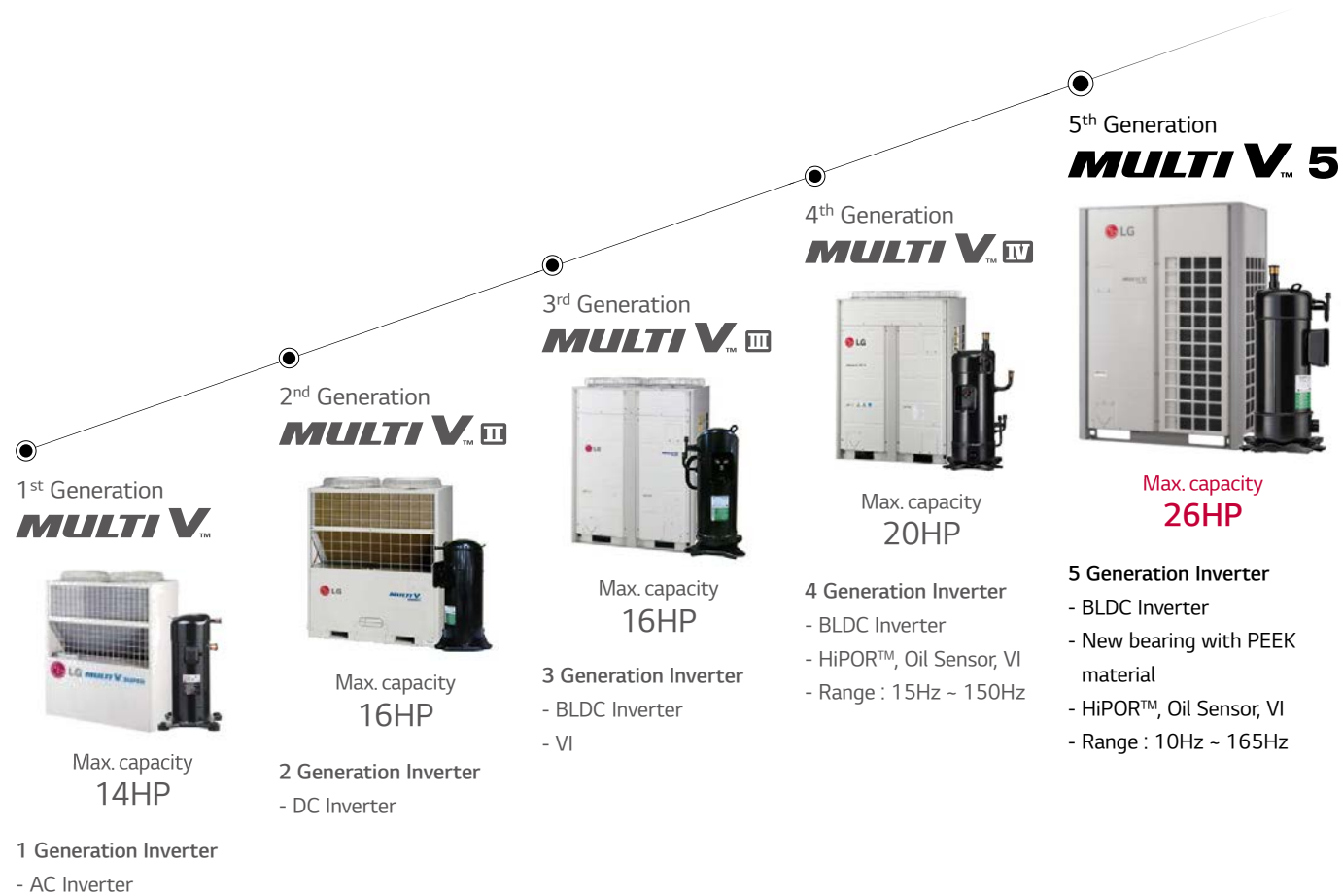

From the moment when LG introduced Korea's first residential air conditioner in 1968, the company has continuously enhanced its technological innovation and credibility. As a result of sustained improvement, LG VRF launched the first generation of MULTI V in 2006 and achieved significant development. With world's top class compressor and innovative technology competency applied on every part, cycle and controlling solutions, it has evolved to be one of the world's most efficient and reliable VRF solutions.

Following the first and second generations with Inverter technology and non-ozone depleting refrigerant, MULTI V III has advanced its efficiency with diverse cutting-edge technologies such as HiPOR™ that directly returns oil to compressor and Vapor Injection that allows double compression by adding mid-pressure refrigerant. The innovative technologies of 4th generation MULTI V secured MULTI V brand with product leadership based on efficient system. For example, Smart Load Control that controls operational load according to external temperature. The other technology is optimized to manage refrigerant and heat exchange for cooling or heating.

Moreover, MULTI V's wide range of VRF line-up satisfies various types and sizes of buildings; MULTI V S is the VRF with side discharge, designed for small to mid-sized building and MULTI V WATER is the water-cooled VRF solution with variable water flow controlling technology.

In 2017, the time has arrived for the ultimate VRF system, MULTI V 5. This generation has fully improved its technological potential with ever powerful and reliable yet economical LG's Ultimate Inverter Compressor, Ocean Black Fin with the most effective corrosion resistance performance and biomimetics technology-applied, enlarged fans. At the same time, the Dual Sensing Control offers users the most pleasant environment while minimizing the unnecessary energy loss with system that senses both the temperature and humidity to efficiently manage cooling, heating and part load operations.

With MULTI V 5 that has been solely designed for the ultimate efficiency, performance, flexibility, comfort and control, we are highly confident to bring the ultimate pleasant air experience.

LOCATION & ADDRESS

MIDDLE EAST	MEA RHQ	LG Electronics MEA AE RHQ 34 th Floor, Shatha Tower, Media City, P.O. Box 502535, Dubai, U.A.E. Phone: +971 4 279 9222
	GULF	LG Electronics Gulf 34 th Floor, Shatha Tower, Media City, P.O. Box 502535, Dubai, U.A.E. Phone: +971 4 279 9222
	TURKEY	LG Electronics Ticaret A.Ş. Kaptanpaşa Mah. Piyalepaşa Bulvarı No: 73 Ortadoğu Plaza Kat:7 34384 Okmeydanı, Şişli İstanbul Phone: +90 212 314 52 52
	LEVANT	LG Electronics Jordan Amman, Abdali Project, Rafik AL Hariri Avenue, The Boulevard, Central Square
		LG Electronics Iraq Erbil, 100m Street, Italain Village 1, Villa 332
		LG Electronics Lebanon Beirut, Saloumeh Highway, Sin El-Fil, Habib Center
		LG Electronics Syria Damascus, Abu Remaneh, Mahdi bn barakeh St., Ghabra and Hmami Building
	SAUDI ARABIA	LG Electronics KSA 3355 Sari st. - Al Khalidiyah dist., Jeddah 101 Building, 5 th Floor, P.O. Box 10876, Kingdom of Saudi Arabia Phone: +966 2 6166627
	ISRAEL	LG Electronics Levant, Tel-Aviv branch. P.O.Box 12169, Medinat Hayehudim 89 St., 4 th Floor, Hertzelia Pituach, Israel Phone: +972-9-973-4525
	IRAN	LG Electronics Tehran Liaison Office 2 nd Floor, No. 37, East Atefi Alley, Africa (Jordan) Blvd, Postal Code: 1917797495. Phone: +98 21 2620 5940
AFRICA	EGYPT	LG Electronics Egypt E5 Services Zone, First Aggregation, Moustafa Kamel Axis, From Cairo-Suez Highway, New Cairo City, Cairo, Zip Code: 11865 Phone: +20 2 26131050/54
	MOROCCO	LG Electronics Morocco Zenith Millenium, Immeuble no 3 et 4, 5eme etage - Lotissement ATTAOUFI Sidi Maarouf - Casablanca - Maroc Phone: +212 522 97 32 32
	ALGERIA	LG Electronics Algeria Sarl. 98, Rue Mohamed Boudiaf, Cheraga, Algiers Phone: +213 21 37 5050
	TUNISIA	LG Electronics Tunisia Immeuble LYS, 3eme Etage, Les Jardins du Lac, Les berges du Lac 2, 1053 Tunis, Tunisia Phone: +216 71 197 877
	SOUTH AFRICA	LG Electronics SA (Pty) Ltd. Raceway Industrial Park, Monte Carlo Drive, Gosforth Park, Germiston, South Africa, P.O. Box 1419 Phone: +27 11 3323 8000
	WEST AFRICA	LG Electronics West Africa (Nigeria) 1 st Floor, Left Wing CBC Towers, Off Abmiralty Way Adjacent, Adjacent Ebanu Super Market, Lekki Phase1, Lekki, Lagos, Nigeria Phone: +234 1 793 6511
		Belas Business Park, LG Electronics Branch Edificio Bengo Torre Aala 102. Municipio de Belas. Talatona. Luanda. Angola. +244 915 460 470
		LG Electronics West Africa (Ivory Cost) AMarcory Zone 4C, Rue Pierre & Marie curie - Adibjan Immeuble Continental Re, 2e Etage, P.O. Box 01 BP 8713, Abidjan 01 Phone: +225 2 022 5886
	EAST AFRICA	LG Electronics Africa Logistics FZE (Kenya) Hanover Tower Block, 4 th Floor, 14 Riverside, Off Riverside Drive, P.O. Box 505-00606 Phone: +254 20 2327363/65
LG Electronics Africa Logistics FZE (Sudan) Amarat 15 th Street, Central Building Khartoum - Sudan, P.O. Box 1220 Phone: +249 183483304/5		

ENGINEERING TOOLS & SUPPORT

From planning to service & maintenance and then to de-construction, an architectural project goes through many stages from the beginning to the end of its lifecycle. Along those stages, various engineering tools are applied to solve the diverse issues happening in each stage, with the most optimal solution possible. Given the usage of such tools, buildings are effectively designed, built, supervised, and maintained throughout their lifecycle.

Dedicated to provide the best HVAC engineering support, LG Electronics Air-Solution Business Unit offers several engineering tools and solutions focused on HVAC, during the overall lifecycle of a building, related to the three categories: I. Draft Energy Estimation & Energy Modeling, II. Model Selection & Design, and III. Installation Environment Simulation. Among them, the LATS* Program series has been developed to offer the best tool for LG HVAC systems, providing our customers a faster, easier, and a more accurate way in everyday duties of Model-selection, Draft Energy Estimation & Designing, and many more.

* LATS : LG Air-conditioner Technical Solution

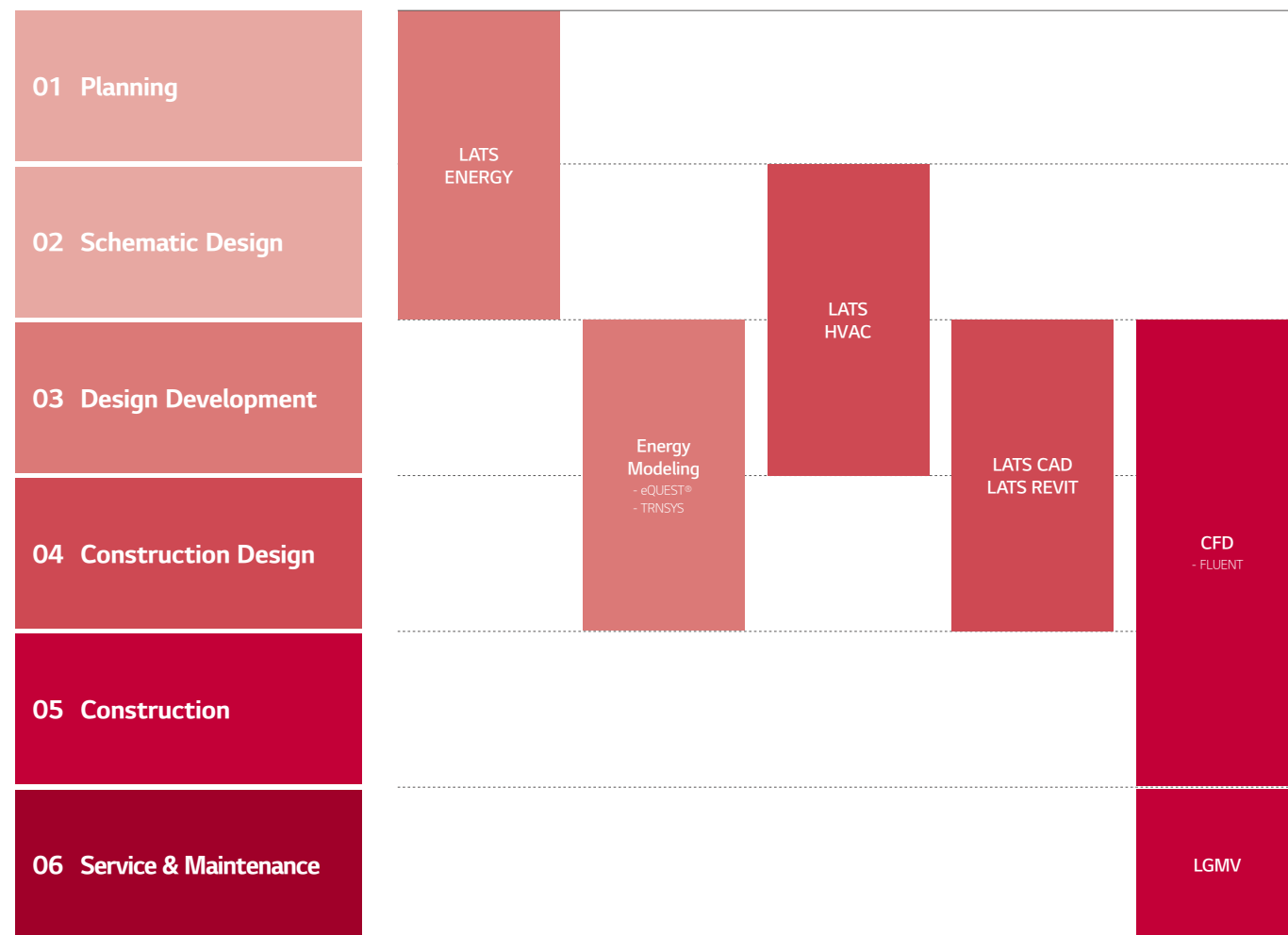
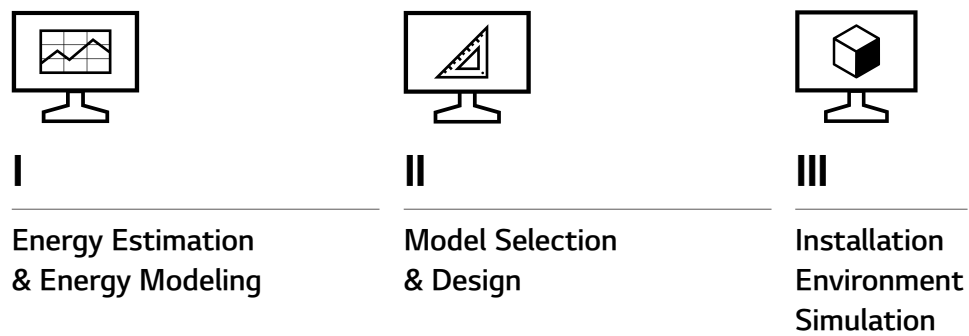

01 Draft Energy Estimation

LATS Energy

LATS Energy program is a draft energy estimation program, self-developed by LG. This program helps estimate the draft energy usage and analyzes the life cycle cost of LG VRF models during the early stage of a project.

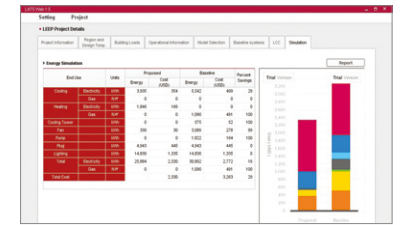

02 Building Energy Modeling

eQuest, EnergyPro, Trace700 and More

These are certified commercial programs which assess the HVAC system efficiency and building's annual energy saving for building standard or certification like LEED. LG HQ supports these programs for the project stages of Design Development and Construction Design wherein the overall designing is finished.

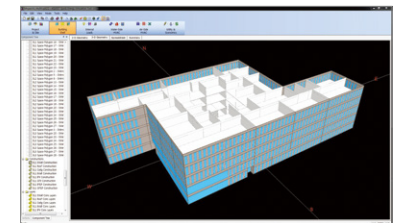

03 Model Selection

LATS HVAC

LATS HVAC is an integrated model selection program of LG HVAC products, enabling an accurate and quick selection on the best model suitable to each sites. In addition to model selection, faster estimation on refrigerant piping diameter and additional refrigerant is possible, along with auto printing of reports.

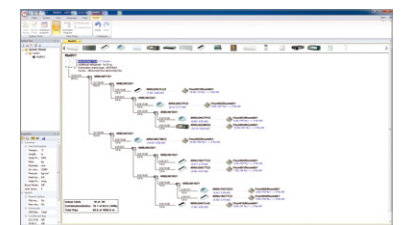

04 Design

LATS CAD

LATS CAD enables faster and more accurate 2D design of LG HVAC products. It also enables modules for quotation and installation review that minimize inherent problems appearing during installation.

* AutoCAD program is required.

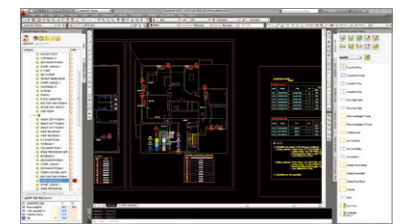

LATS Revit

LATS REVIT is developed to make 3D design of LG HVAC products.

* AutoCAD Revit program is required.

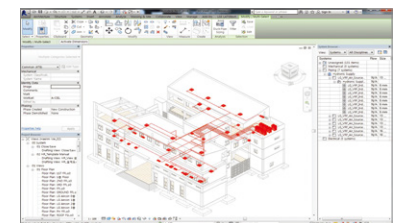

05 Environment Simulation

CFD Analysis

CFD Analysis is applied in areas of estimating: indoor airflow and temperature distribution while operating VRF products, outdoor airflow distribution, and noise level. By running a simulation before construction, engineers estimate possible issues and find optimal solutions of malfunction that could occur after construction.

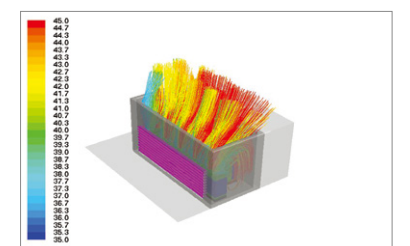

06 Service & Maintenance

LG MV

LG MV offers real-time MULTI V cycle monitoring. During start-up, it's possible to check whether it is normal operation or not. Also it helps to find causes of errors and solve the problem faster.

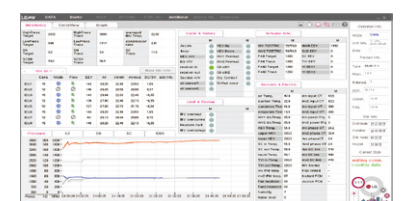

BENEFITS OF LG MULTI V

Benefits for Building owners



Efficient Management & Cost Reduction

- Fault Detection Diagnosis enables easy maintenance
- Requires no extra manpower does not require regular manpower for maintenance
- With diverse control systems, maintenance cost is minimized



Reliability Guaranteed in Every Aspect

- Ultimate Inverter Compressor developed and manufactured in Korea
- Corrosion resistant Ocean Black Fin for harsh condition operations
- Smart Oil management (Auto Oil Balancing and Active Oil return) decreases compressor damage



Customized Comfort and Solution

- Compatible option between Heat pump and Heat recovery system is possible



Benefits for Developers / Construction companies



Green Solutions

- Helps scoring LEED/BREAEM points
- Renewable energy solution provided through geothermal application



Maximizing Space Utilization

- Large Capacity in compact size enhances space utilization



Smart Building Solutions

- Easy interlock with Building Management System
- Wi-Fi control available for anytime anywhere (via mobile app)
- Energy management and control according to usage and planning is possible with LG's centralized control solution



Benefits for Consultants



Versatile Solutions

- Air-cooled, Water-cooled, Heating, and Air Handling Unit interlocked solutions



Professional Designing Support

- LATS(LG Air-conditioner Technical Solution) for draft energy estimation, model selection, HVAC design and 3D designing
- CFD Analysis to ensure suitable solutions and prevent malfunctions
- Energy simulation offered to find the optimal solution



Optimized Comfort in HVAC Designing

- Flexible and Longer piping length eases HVAC designing process
- Meets any type of customer requirements of diverse environment, design condition, and building applications



Benefits for End-users



Operation Cost Saving

- High efficiency is assured through all capacity and lineup
- Maximum 31% of cost saved through MULTI V 5 Smart Load Control*



Comfortable Cooling & Heating

- Smart Load Control maximizes indoor comfort level
- Dual sensing offers pleasant and comfortable cooling and heating environment
- Duration time of Continuous Heating is 11% longer than previous model**



Convenient Functions

- Low-noise operation provides a restful environment

* Dual Smart Load Control ESEER based, below 50% humidity, model ARUM260LTE5
 ** LG internal test result

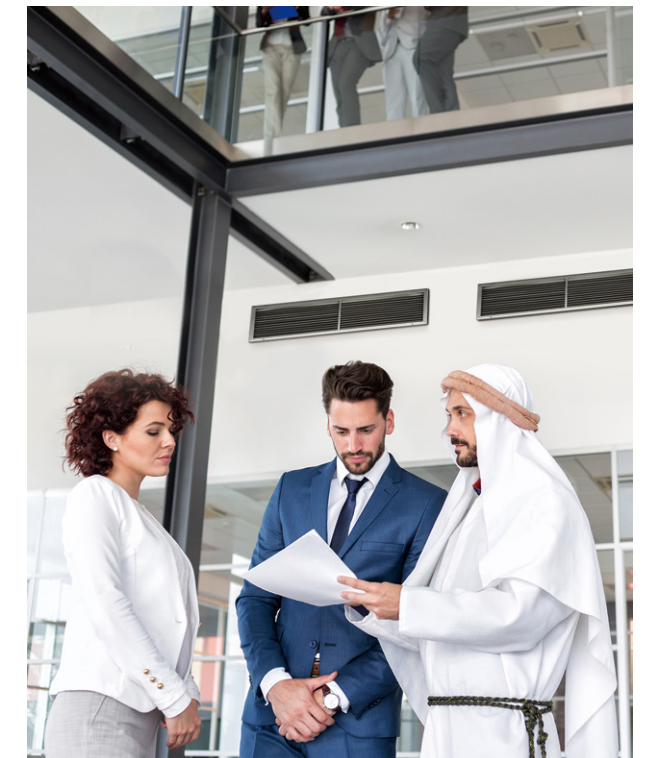

APPLICATION SOLUTIONS

Office Supporting efficiency with flexibility

High Rise Office Building



- MULTI V WATER IV
- High Static Duct
- Variable Water Flow Control Kit
- DX AHU
- PDI

Small to Medium sized Office Building



- MULTI V S / S
- 4 Way CST
- PDI

MULTI V series vitalizes the workspace with fresh air at all time, combined with its various indoor selection. The intelligent control solutions add comfort to the space.

Residential Home is where your comfort is

Condominium & Apartments



- MULTI V S HR
- 1/2 Way CST
- Hydro Kit
- 3rd Party Controller RTU Gateway

Single Family House & Villa



- MULTI V S
- Therma V
- ESS & PV Solar

Remarkably compact size and high static pressure of MULTI V S enables optimal space solution, providing comfort to every space through individual zone control and hot water solution

Commercial Maximize business, minimize costs

Shopping Mall



- MULTI V 5
- DX AHU

Retail



- MULTI V M
- ERV
- Convertible

QSR



- MULTI V M
- ERV
- Hydro Kit
- 4 Way CST

The highly efficient, energy saving MULTI V 5 and MULTI V M reduces operation costs, and provides comfort that suits any purpose and any space, helping to invest the extra space and expense to your business.

* CST : Cassette * PDI : Power Distribution Indicator

Hospitality Meeting diverse needs in every aspect

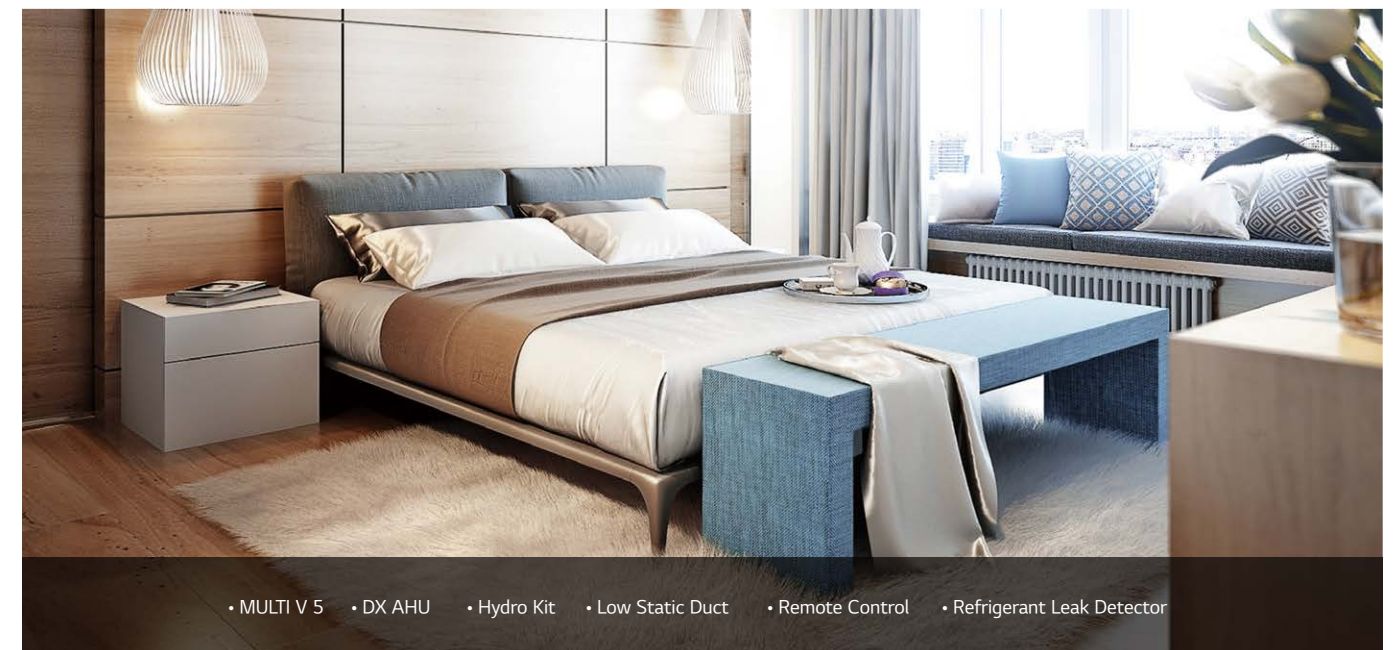

- MULTI V 5
- DX AHU
- Hydro Kit
- Low Static Duct
- Remote Control
- Refrigerant Leak Detector

The diverse applications that can be applied to MULTI V 5 helps bring just the right solution to a sophisticated hotel business.

* ESS : Energy Storage System * PV : Photovoltaics

DIVERSE INTEGRATED SOLUTION

Hot Water Solution

In order to save costs of providing hot water, using heat pump system is advised as water heating by heat pump is highly efficient compared to a boiler system. The Hydro Kit can be connected to MULTI V 5, and hot water temperatures up to 80°C can be provided. Also, energy savings can be increased when Hydro Kit is combined with MULTI V 5 Heat Recovery.

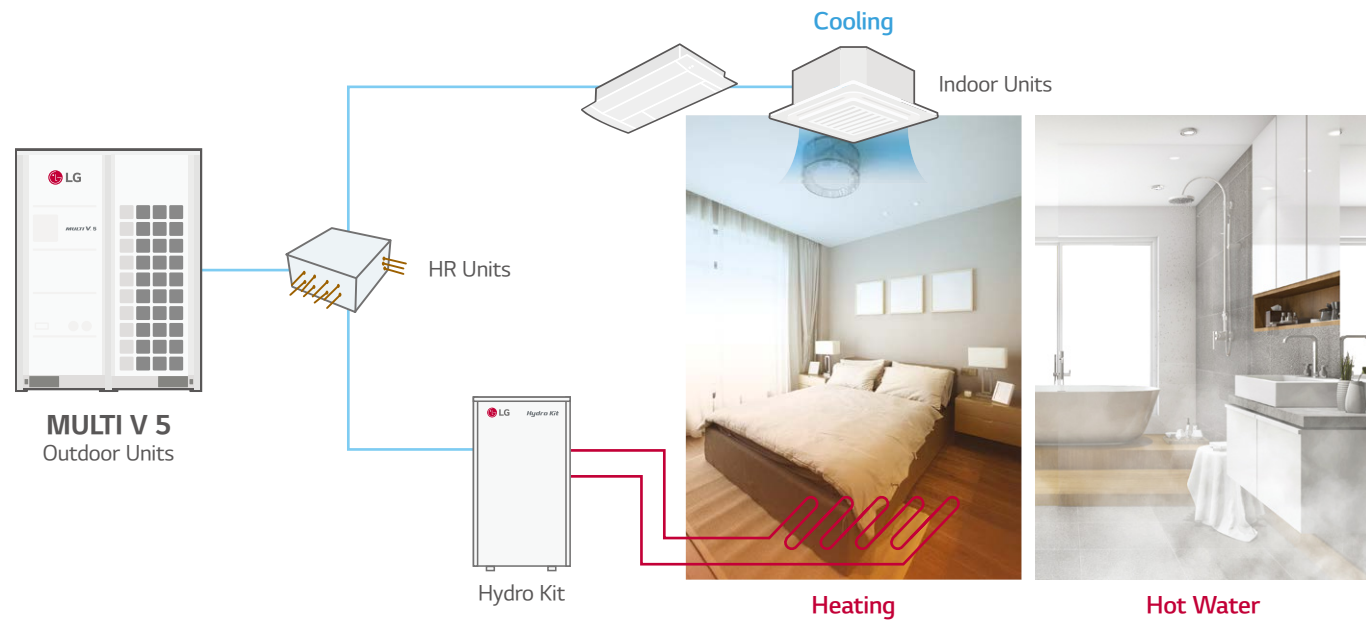

Refrigerant Leak Detection Solution

Real time refrigerant leak detection is needed for a safe environment. When the refrigerant concentration exceeds 6,000ppm for 5 seconds the indoor unit will stop operation and can also give an alarm using a buzzer or a light with the dry contact (option). The central controller can also display an error signal.

* When the solution for refrigerant leak detection is required, contact LG and discuss the requirement

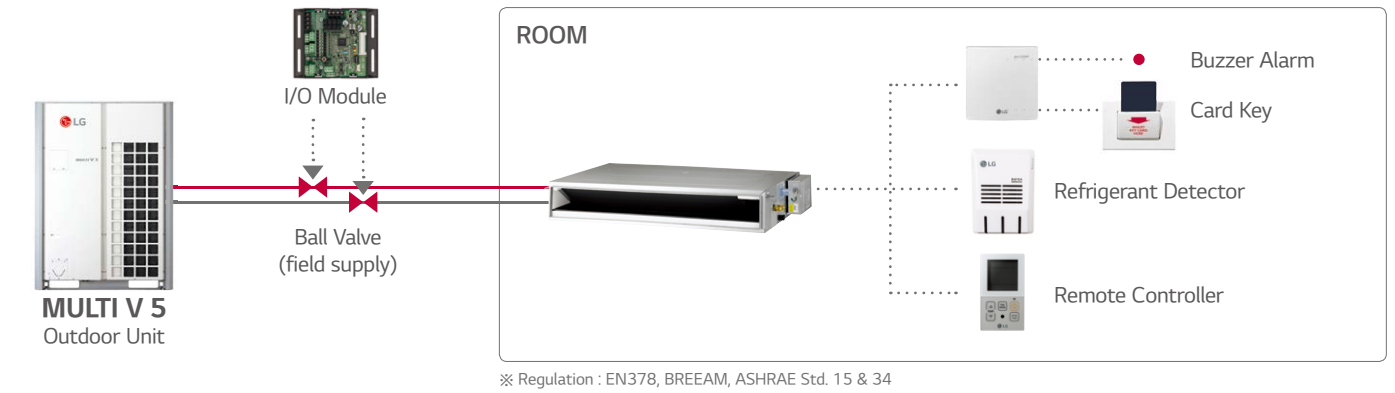

Air Handling Unit(AHU) Solution

An AHU is a solution that can control all air conditioning factors in a large space. With an LG AHU Comm. Kit (for both return air / supply air control) connected to the DX coil of the AHU, LG VRF system can be applied to deliver conditioned air.

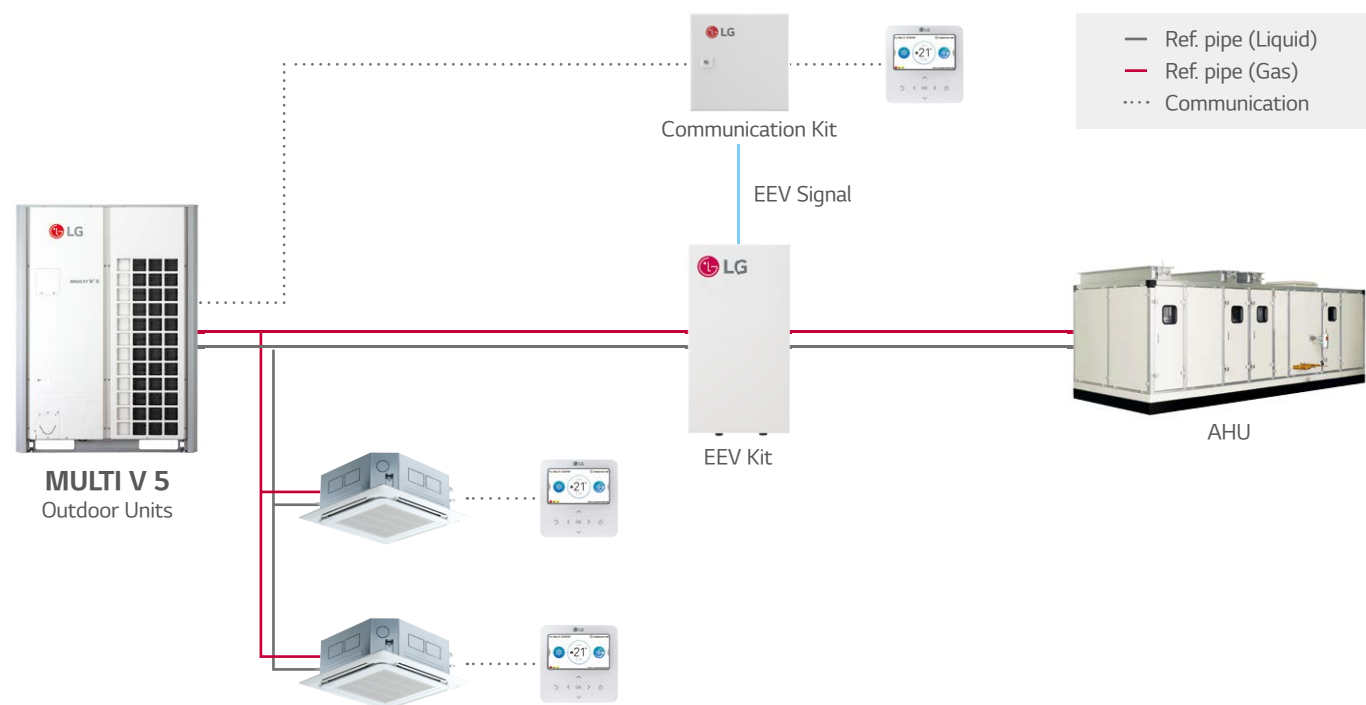

Power Consumption Distribution Solution

In case of shared power consumption in a building, a solution to distribute the power consumption amount per tenant might be necessary. Electricity charges can be billed to each tenant by using output from the LG Power Distributor Indicator (PDI). An administrator is able to check the power usage for each space and date as needed. If the PDI is used in conjunction with an LG central controller, the results can be exported to Excel.

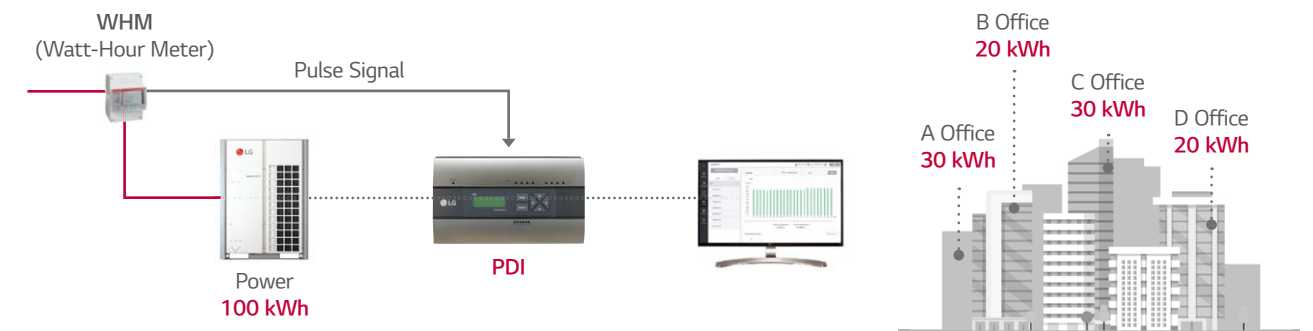

Total Control on Any of Devices

In order to manage multiple spaces and multiple buildings, the administrators should be able to control systems from wherever they are. The LG central controller can be controlled from any web browser that supports HTML5. Now through the implementation of HTML5, the interface will look great and perform well on any of your devices.



DIVERSE INTEGRATED SOLUTION

Energy Management Solution

Since HVAC systems have a significant portion of any building's total amount of energy, the energy saving functions of a controller can make a big difference. The energy navigation function enables you to set target values for energy consumption over a certain period of time. In addition, to achieve that value, the administrator can set the energy saving logic in 7 steps and predict the expected usage relative to the target value. Active self-management enables energy savings through out the building.



Interlocking Solution by Using ACS IO Module

It is costly to introduce a BMS system to control multiple devices or systems in a small building. With the ACS IO module, various IO contact points (DI, DO, UI, AO) can be interlocked and integrated control is possible from the LG central controller. This enables an efficient management of lighting, pumps and other devices in the building in onjunction with the HVAC system.

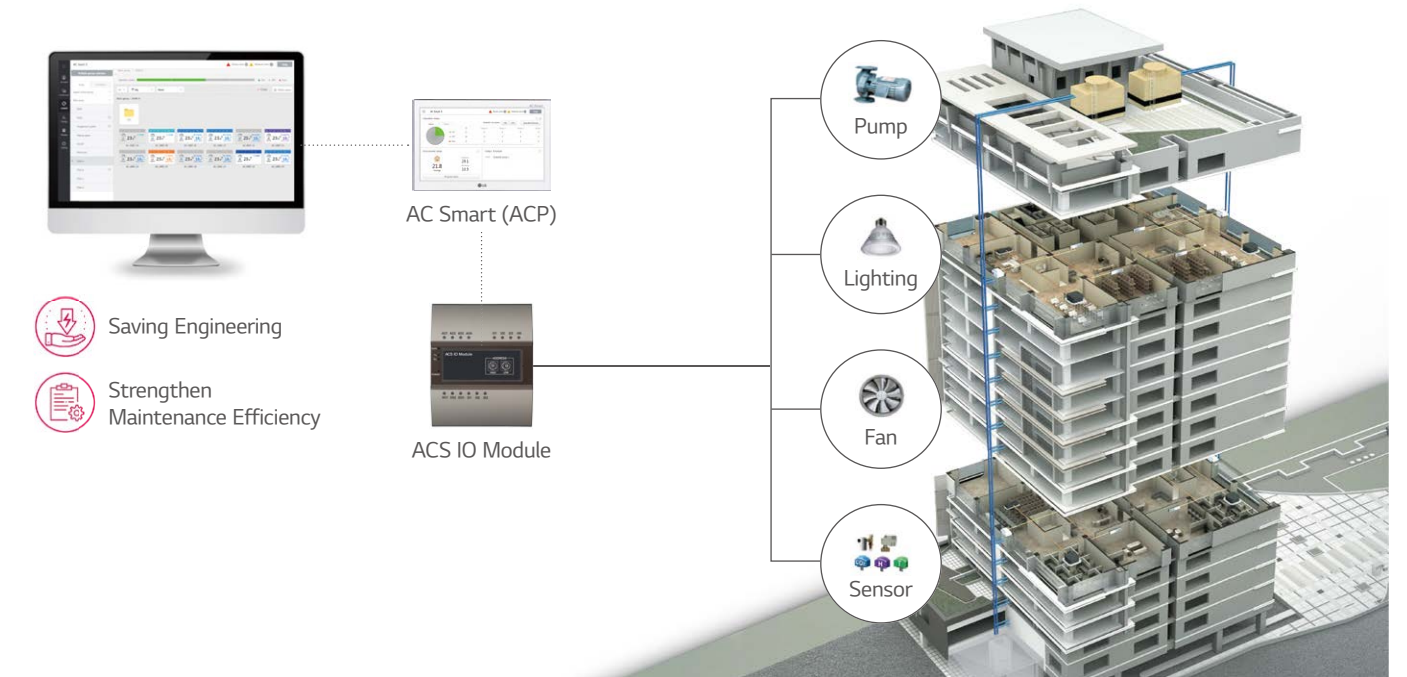

Integration Solution with BMS

There are many BMS protocols used for the control of buildings' various systems such as HVAC, lighting, power and security. LG has a wide range of gateway products for different protocols such as BACnet, Modbus, and LonWorks. In addition, LG gateways include Stand-alone central control capability to act as a back-up controller of the BMS if needed.

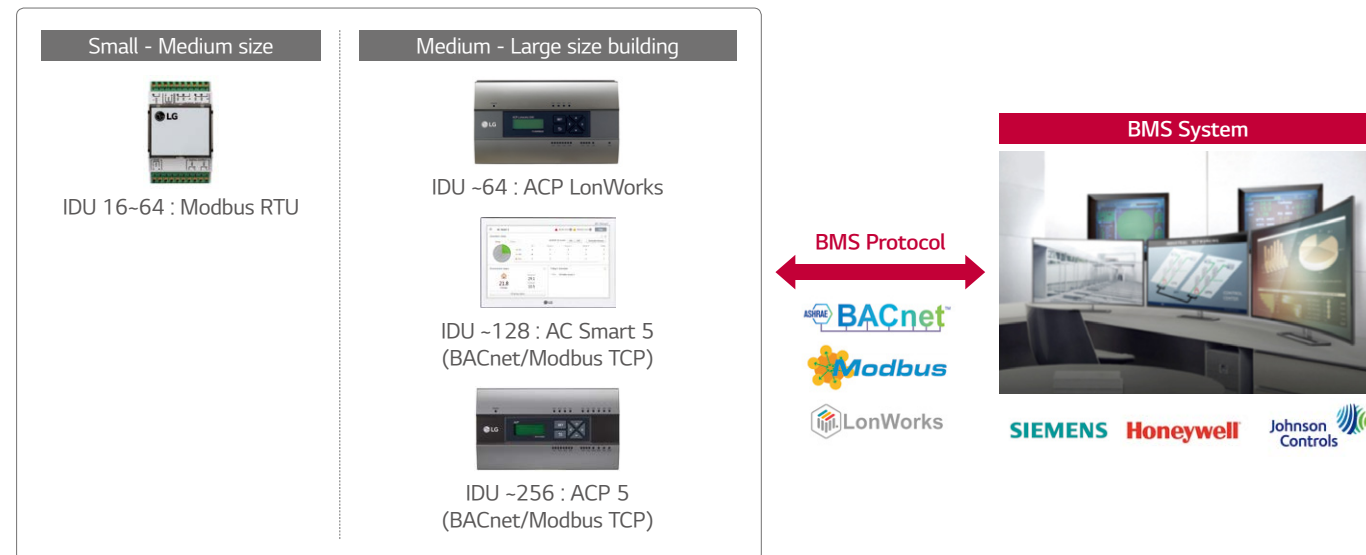

Interlocking Solution by Using Dry Contact

3rd party thermostats can be used to control LG air conditioners in a room by using a multi point dry contact. The dry contact enables basic control of air conditioners as well as making it possible to report the status and any errors impacting the indoor unit. The Standard III remote control has a DO port. With this DO port, it is possible to interlock the indoor unit with 3rd party devices such as lighting, a fan, or a radiator, based on things like operation mode or current temperature. The indoor unit can be interlocked with various types of input such as card key-tag, door sensor, human detection sensor etc. so that the air conditioner is automatically operated depending on situation. In addition, the dry contact option settings enable operation of air conditioner to maintain proper temperature when the occupant is absent. This solution makes sure that the room does not overheat or become too cold when unoccupied so that energy cost can be saved.



OUTDOOR UNITS

MULTI V 5 / MULTI V S / MULTI V M

MULTI V WATER IV (HEAT PUMP / HEAT RECOVERY)



OCEAN BLACK FIN HEAT EXCHANGER

Strong durability regardless of external environment



Ocean Black Fin

What benefits do you offer?

-  Extended Product Life Cycle
-  Minimal Environmental Pollution
-  Efficient Operation
-  Reduced Maintenance Costs





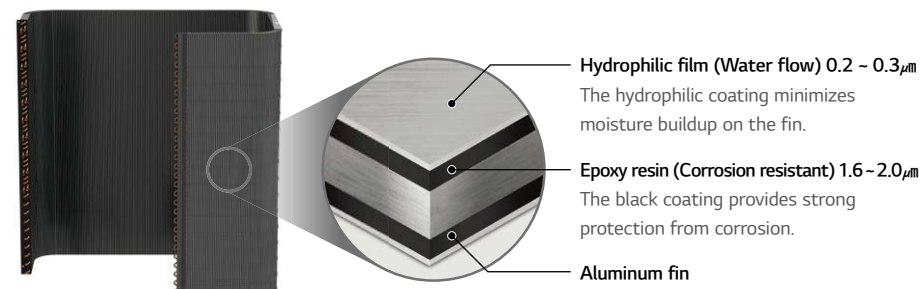

LG's exclusive "Ocean Black Fin" heat exchanger is specially designed for durable and long-lasting performance even in corrosive environments. The black coating is applied for protection from various corrosive external conditions and the hydrophilic film keeps water from accumulating on the heat exchanger's fin, minimizing moisture buildup. This improvement in durability prolongs the product's lifespan and lowers both the operational and maintenance costs.

Heat Exchanger with Ocean Black Fin for Corrosion Resistance

The black coating is applied for protection from various corrosive external conditions and the hydrophilic film keeps water from accumulating on the heat exchanger's fin, minimizing moisture buildup.

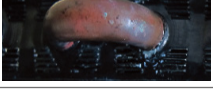

Condition of salt spray test

Heat Exchanger	Test Period (hr)		
	1 000	2 000	3 000
Previous Fin			
Black Fin			

* Based on in-house testing.
* Test conditions: KS (D 9502), ASTM - B117, Temp: 35+°C / NaCl Concentration: 5% / Avg. spray rate: 1.5 + 0.5 ml / hr

Corrosion Resistance Proven by Certified Tests

LG Corrosion Resistance solution passed ISO accelerated corrosion test conducted by an independent test organization and the result has been certified by prestigious global certification organization, UL (Underwriters Laboratories).

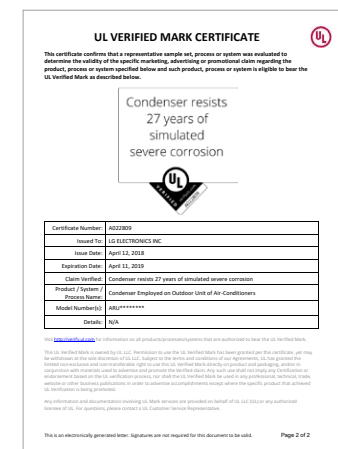

* Certificates can be updated.
* TUV certification will be obtained in March 19

DUAL SENSING CONTROL

Energy savings and optimized cooling through temperature and humidity control

Previous VRF

Hot day

SINGLE SENSING CONTROL



Temperature

MULTI V. 5

Hot & Wet day



DUAL SENSING CONTROL



Humidity + Temperature

Hot & Dry day

What benefits do you offer?

-  Energy Reduction
-  Pleasant Indoor Environment
-  Convenient Monitoring with PREMTB100 / PREMTBB10

The cooling load is based on the amount of both sensible heat load and latent heat load. Most importantly, the cooling load is kept low, and thus, greatly affected by external humidity, rather than the outdoor temperature. For this reason, MULTI V 5's Dual Sensing Control applied function senses both temperature and humidity and applies sensed data for load control in order to obtain in-depth understanding of sensible heat load and latent heat load. This helps preventing excessive cooling load supply and offers the most pleasant and comfortable cooling environment the users want combined with reduction in energy consumption.

Smart Load Control (SLC)

Smart Load Control function enables comprehensive understanding of environmental conditions in order to optimize energy efficiency and maximize indoor comfort level. This technology allows active control of discharge refrigerant temperature which eventually increases the ESEER up to 21% for maximum 26 HP and 15% for average outdoor units in comparison to the previous models.

ESEER Up to 21% ↑
(vs. standard mode at 26HP)

ESEER Up to 15% ~ ESEER Up to 31%
(High humidity) (Low humidity)

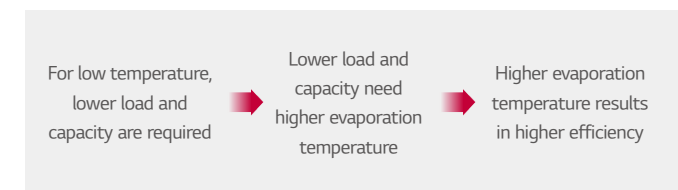

Comfort Cooling

Without stopping in between operations, this function allows MULTI V 5 to maintain operation at mild cooling mode around the set temperature by sensing both temperature and humidity with Dual Sensing Control. By preventing both cold draft and repeated turn on/off's previously required to match the set temperature, users can experience more comfortable indoor environment.

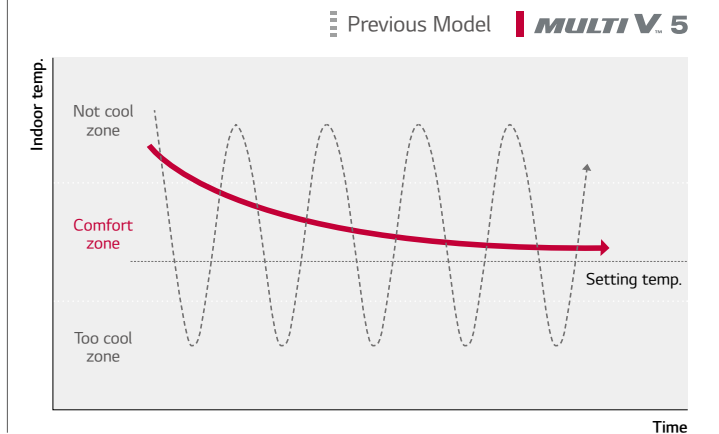

OUTDOOR UNITS / INDOOR UNITS / HOT WATER SOLUTION / VENTILATION SOLUTIONS / CONTROL SOLUTIONS / ACCESSORIES

BIOMIMETICS TECHNOLOGY FAN

Maximum capacity and efficiency

10% Improved Air Flow Rate

20% Reduce Power Consumption

LARGE CAPACITY
WITH BIOMIMETICS TECH

What benefits do you offer?

- Large Capacity
- Low Noise
- Energy Saving

Increased Air Flow Rate (80 mm)

Humpback Whale Design

Clam Shell Pattern

Enhanced core parts like biomimetics technology-based fans, 4-sided heat exchanger as opposed to 3-sided heat exchanger of previous model and compressor with increased efficiency and capacity allow large capacity for outdoor units. A single unit of MULTI V 5 can provide up to 26HP

Larger Capacity ODU with Biomimetics Technology Fan

1 Humpback Whale Design
Inspired by the bumps on the humpback whale's flipper, the tubercles on the back side increased wind power by reducing flacking.

2 Clam Shell Pattern
Like the clam shell textures, the range difference created by moire pattern reduced noise level.

3 Increased Air Flow Rate
With extended shroud, discharged air current is stabilized and power consumption is reduced.

Enhanced Performance with Newly Developed Fan

Based on the biomimetics technology, the fans of MULTI V 5 increased air flow rate by 10% in comparison to previous model and reduced its power consumption up to 20%. This eventually results in maximized performance with large capacity.

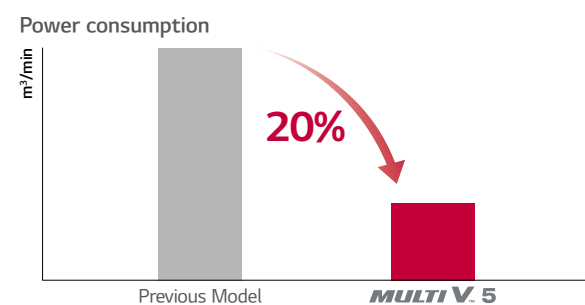
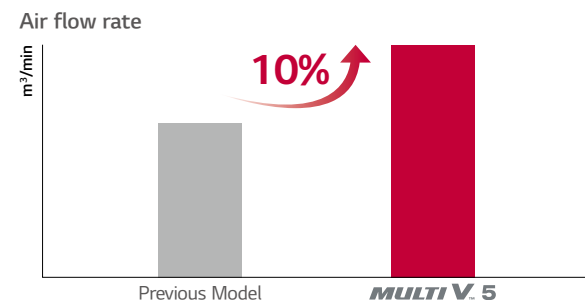

ULTIMATE INVERTER COMPRESSOR

The best durability and efficiency

UI ULTIMATE INVERTER COMPRESSOR

01. HiPOR™ (High Pressure Oil Return)

02. Smart Oil Management

03. Wide Operation Range from 10 to 165Hz

04. Enhanced Bearing with PEEK Material

Up to 15% Operating time without oil supply

Down to 3dB Noise Level (Max. Sound Pressure)

05. Vapor Injection

10% Improved Energy Efficiency

What benefits do you offer?

- High Efficiency
- Low Vibration
- Low Noise
- Excellent Durability

As the core technology of the air conditioning system, the Ultimate Inverter Compressor of MULTI V 5 boasts its ultimate efficiency and durability, designed based on the unique technology and innovation of LG HVAC.

HiPOR™ (High Pressure Oil Return)

Resolve compressor efficiency loss caused by oil return.

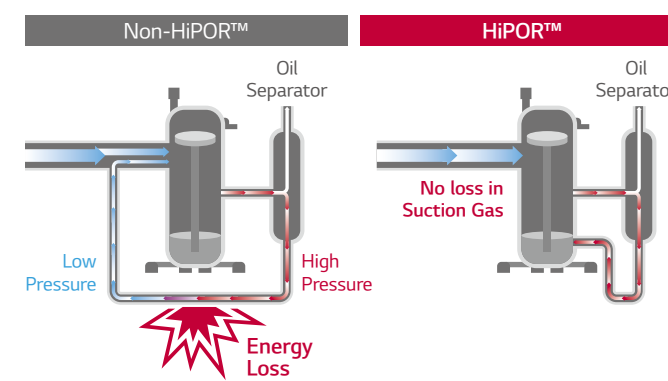

Wide Operation Range from 10 to 165Hz

Wide operation range allows precise control. So improved part load efficiency at all operation ranges.

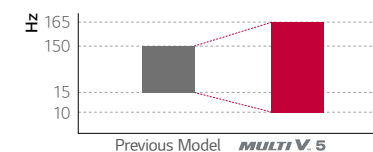

Enhanced Bearing with PEEK Material

Newly invented system motivated by PEEK (Polyetheretherketone) bearing used for aero engine to increase operation range and durability.

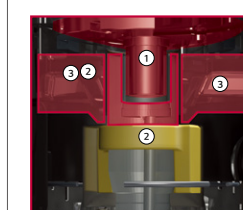

- ① Material : PEEK (Polyetheretherketone)
Strong material used in airplanes
- ①+② Structure : New Outer Bearing
- ③ Supporter : High speed operation with reduction of bearing load and vibration

Smart Oil Management

Compressor reliability and efficiency are improved with an oil sensor that allows oil balancing and oil return.

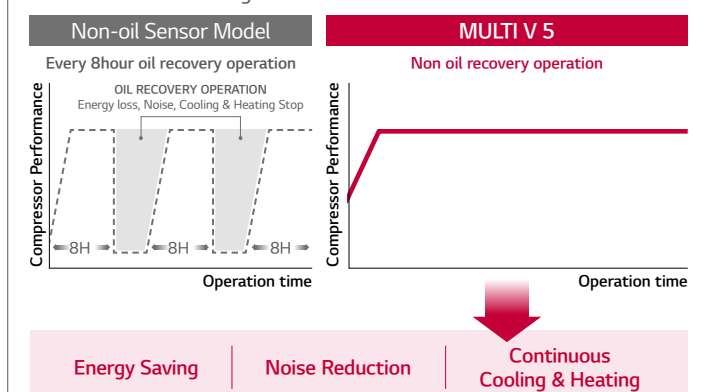

Vapor Injection

Maximize heating capacity via two-stage compression

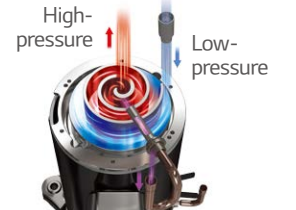

CONTINUOUS HEATING

Efficient even in low-temperature, high-humidity environments

* Only for applied ARUMXXX model.

CONTINUOUS HEATING

Dual Sensing Control | **Partial Defrost** | **Smart Oil Management**

What benefits do you offer?

- Operational Efficiency
- Energy Reduction
- Effective in Various Environments

Improved technologies such as Dual Sensing Control, Partial Defrost and Smart Oil Management enhance Continuous Heating for increased heating capacity and indoor comfort. The delayed and partial defrost technologies minimize unnecessary operational consumption to provide consistent heating.

Partial Defrost

Unlike the previous model that stopped heating operation for one-time defrost, MULTI V 5 partially defrosts the heat exchanger by dividing it to lower and upper parts in order to provide consistent heating for the indoor environment and improve heating capacity.

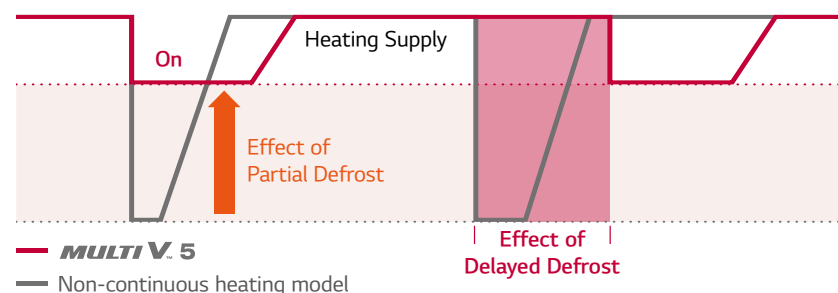

↑ Heating Operation Time Per Day **Up to 11%**
↓ Power Input **Down to 7%**

* LG internal test result
* Test condition : Outdoor 2/1°C, Indoor 20/15°C, Humidity 83%

Delayed Defrost via Humidity Sensor of Dual Sensing Control

By controlling the evaporation temperature considering the humidity, heating operation time is improved.



Smart Oil Management

Oil sensor of the Ultimate Inverter (UI) Compressor enables smart oil management to provide enhanced heating operation without periodic oil recovery operation.

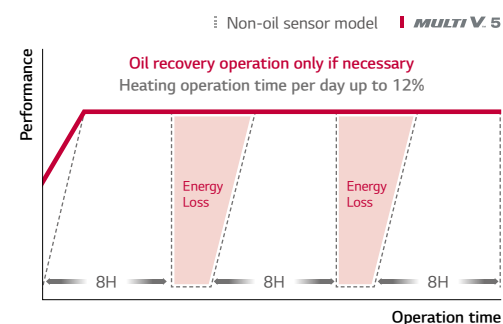

AUTO DUST REMOVAL

TROPICAL MODEL

Enhanced stability from environmental constraints

Auto Dust Removal

What benefits do you offer?

- Stable Operation
- Response to Certain Natural Environments
- Enhanced Durability
- Reduced Maintenance Costs

This feature in MULTI V 5 removes dust on outdoor unit heat exchanger. The outdoor unit fan(s) rotate reversely to blow off the dust. Once the accumulated dust on the heat exchanger is removed, the fan(s) rotates normally and unit goes back to normal operation.

Technology Mechanism

Fan rotates **reversely** to run sand dust free operation

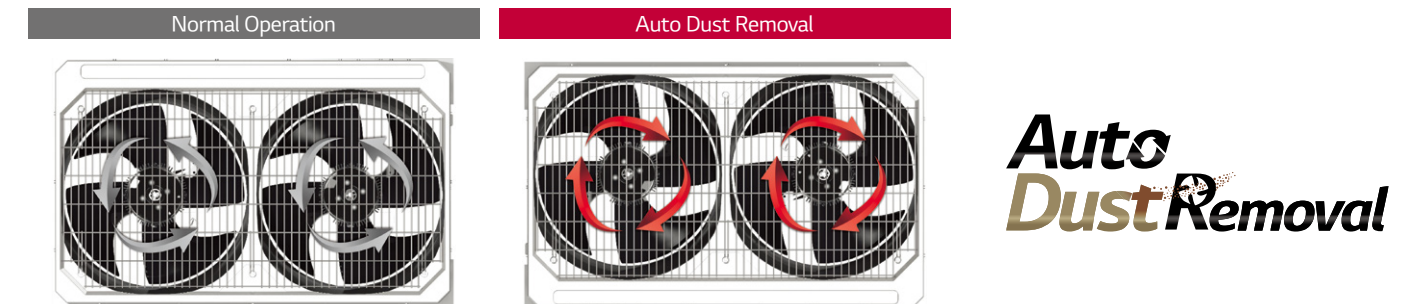

Performance Comparison



MULTI V 5

Piping Length

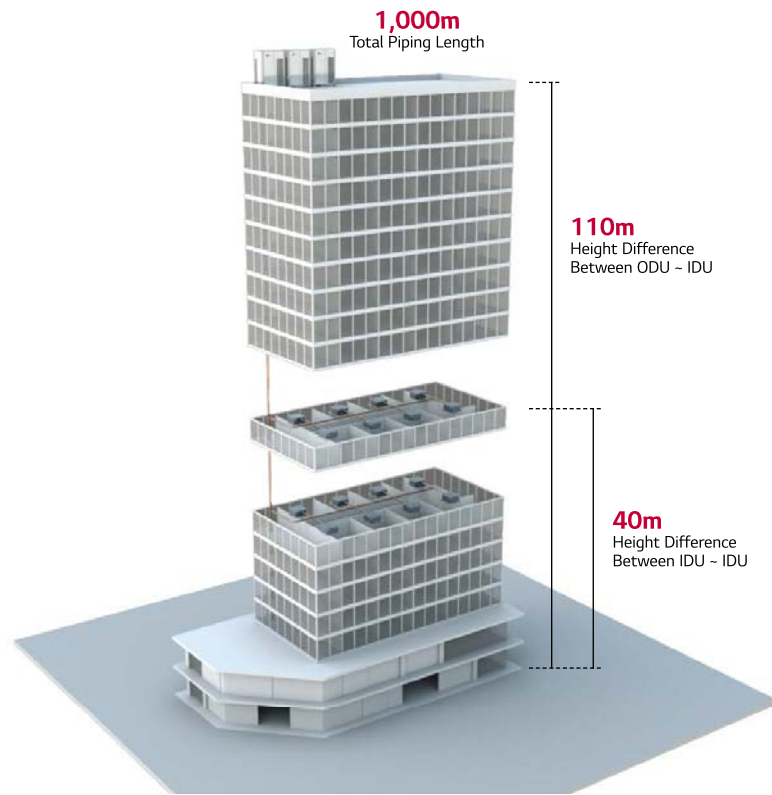

Total Piping Length	1,000m
Actual longest piping length (Equivalent)	200m (225m)
Longest piping length after 1 st branch (conditional application)	40m (90m)
Height between ODU - IDU	110m
Height between IDU - IDU	40m
Height between ODU - ODU	5m

Variable Path Heat Exchanger

Optimized system efficiency & continuous heating

MULTI V 5 outdoor units are manufactured with horizontally split ODU coil consisting of two independently circuited sections. Each half the coil is independently controlled. This split coil feature makes it possible for MULTI V 5 to provide continuous heating during defrost. The coil circuiting and valve arrangement also makes it possible for the MULTI V 5 controller to change the flow path of refrigerant through one of the two coils only, or through both coils in either a series or parallel arrangement. Based on system pressures, ambient temperature conditions, and mode of operation, the system controller may modify the selected path at any time.

What are the benefits?

Optimizes system efficiency irrelevant of operating modes as ambient weather conditions change. Customizes the area of outdoor units heat transfer surface in use dynamically.

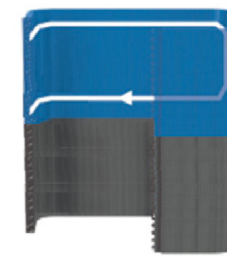

Low ambient cooling and / or light building load

- Half active
- Lower idle



Full load cooling

- Upper & lower active
- Series circuited
- High velocity refrigerant flow



Heating - all conditions

- Upper & lower active
- Parallel circuited
- Low velocity refrigerant flow

Active Refrigerant Control

Stable operation & Sustaining most efficient operation

The accumulator in the outdoor unit has a storage tank mounted inside accumulator known as the receiver tank. The receiver tank is equipped with inlet and outlet valves that are electronically opened and closed. Refrigerant is being passed between the accumulator and the receiver tank on a continuous basis. MULTI V 5 active refrigerant control algorithm goal is to minimize the amount of refrigerant in circulation. The lower the volume in circulation the lower the cost to move it around the system and the higher the stability of the refrigeration cycle. It accomplishes this by constantly monitoring the system operating pressures and temperatures and a variety of other vital control metrics of the refrigeration cycle. When the cycle is out of balance, an adjustment in the amount of circulating refrigerant occurs.

What are the benefits?

Widens the ambient temperature range at which stable operation occurs. Sustains most efficient system operation irrelevant of outdoor weather conditions, operating mode, or building load.

Technology mechanism

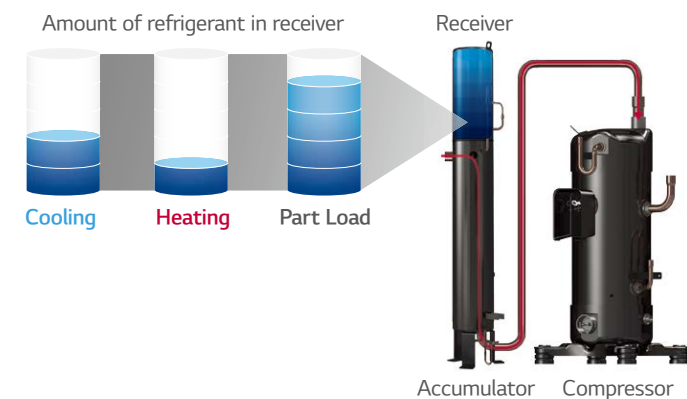

Efficiency performance

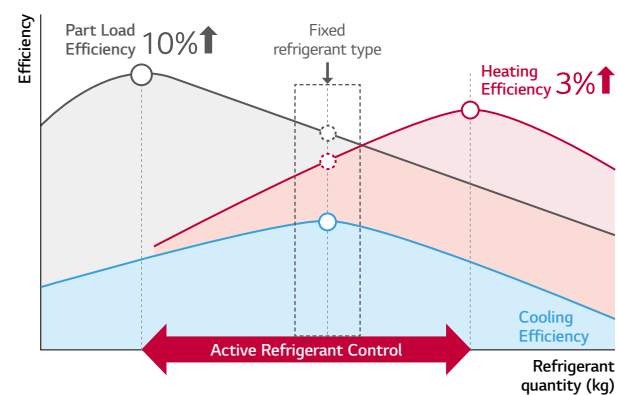

Efficiency

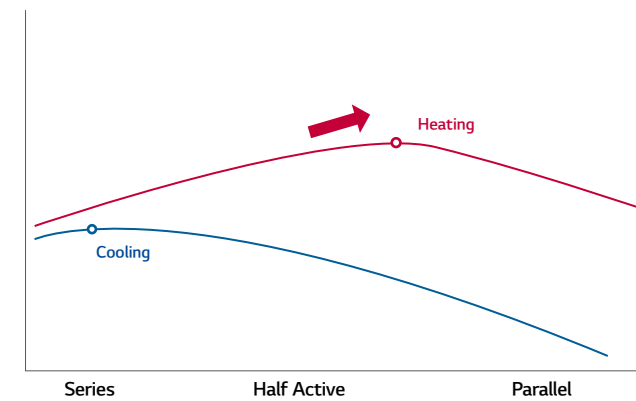

Continuous Heating

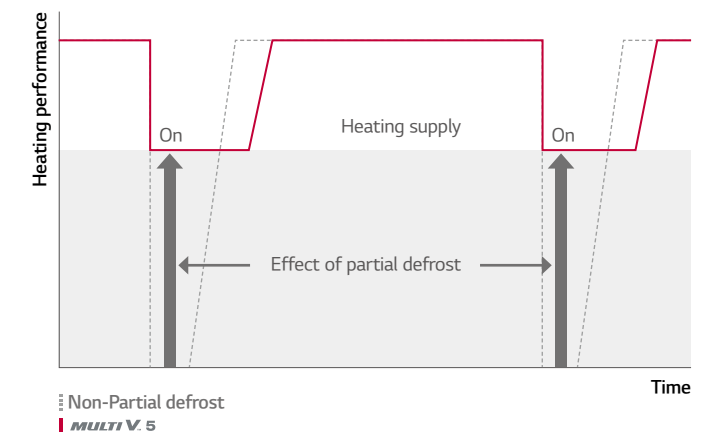

MULTI V 5

Low-Noise Operation

Unlike the previous model which enables Low-Noise Operation only during night after judgment time, the Low-Noise Operation of MULTI V 5 can function regardless of the time at the noise sensitive areas.

Automatic

Noise automatically adjusted



Manual

Choose preferred settings with remote based on noise conditions



* Indoor unit set up available with Standard III Remote Controller

Flexible Installation Space with Large Capacity Outdoor Units

Large capacity outdoor units of MULTI V 5 minimizes installation space that spares valuable floor space and significantly decreases total installed weights. This allows users the flexible design potential and better use of the saved space.

Comparison on installation space



Installation space area comparison

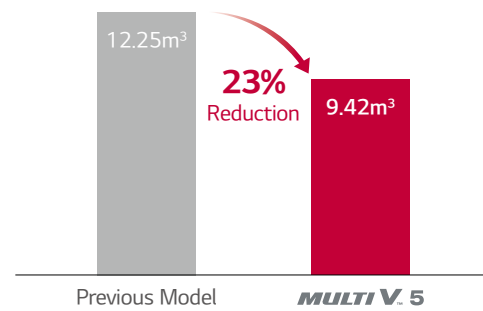

Product weight comparison

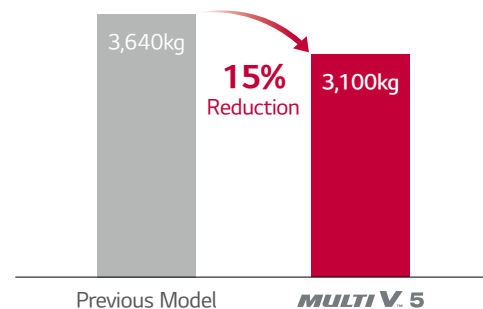

Dual Sensing SLC (Smart Load Control)

Enhanced energy saving & Increased indoor comfort

Cooling loads vary according to both temperature and humidity. With Dual sensing SLC, the proper amount of work can be exerted to meet the load not only depending on current temperature, but also on humidity. As a result, less work will be needed at the same temperature when humidity is lower. It influences the VRF system main processor's decision on where to set the system's target high or low system pressure values.

Smart Load Control monitors two inputs

- 1) Outdoor ambient dry bulb temperature
- 2) Outdoor ambient relative humidity (when enabled)

Cooling Indoor Units - adjusts target low pressure

Raises the target low pressure value as cooling load falls and/or ambient temperature falls.
Lowers the target low pressure value as cooling load rises and/or ambient temperature rises.

Heating Indoor Units - adjusts target high pressure

Lowers the target head pressure as heating load falls and/or ambient temperature rises.
Raises the target head pressure as heating load rises and/or ambient temperature falls.

What are the benefits?

Enhanced energy savings

- Cooling Mode

By raising the target low pressure during off-peak cooling operation, the compressor lift is reduced. This slows compressor's speed which leads to a decrease in compressor's power consumption.

- Heating Mode

By lowering the target high pressure during off-peak heating operation, the compressor lift is reduced. This slows compressor's speed which leads to a decrease in compressor's power consumption.

Increased indoor comfort

Smart Load Control uses one (or two) sensors to measure changing outdoor weather conditions and prepares the VRF system for operation under the revised weather conditions before the changed conditions have a chance to impact indoor comfort.

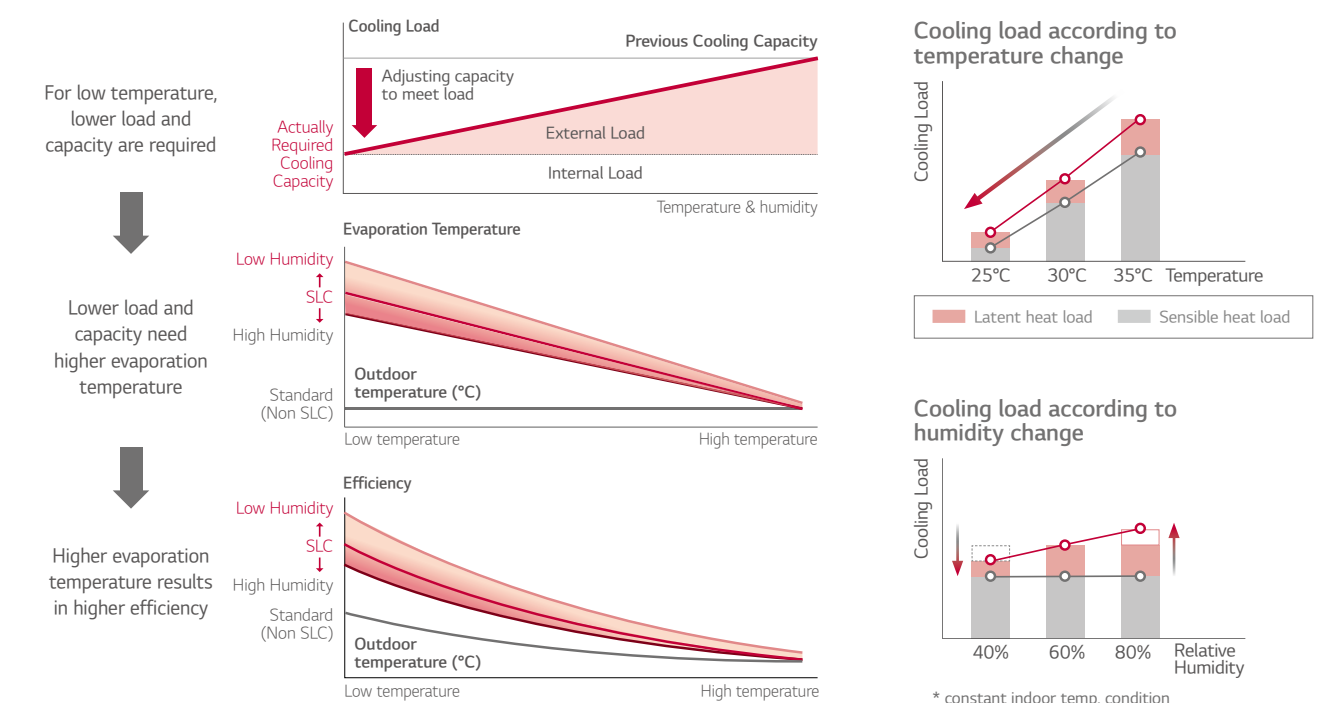

MULTI V 5

Comfort Cooling

Increased indoor comfort & Enhanced operating efficiency

When the IDU is operating in a season when its load is less than design, the comfort cooling algorithm moderates the indoor unit's coil superheat, thus raising the leaving air temperature as the space temperature is approaching set point. MULTI V 5's comfort control algorithm monitors the outdoor air temperature and humidity conditions. When changing weather conditions are deteriorating and there is a high potential the indoor unit's load will remain stable or may increase, comfort cooling delays or abandons raising the target superheat as the room temperature approaches set-point. When changing weather conditions are favorable to raising target superheat, target superheat is moderated.

What are the benefits?

Increased indoor comfort

If comfort cooling is turned off, and the temperature of the leaving air is not raised, when the fan speed is reduced to low speed, there is a potential that occupants located directly under a cassette IDU or supply air registers could feel cold air falling on them resulting in a lower overall comfort experience. With comfort cooling turned on, the leaving air temperature is moderated. When the IDU controller reduces the fan speed, the potential for cold air falling on occupants located under the cassette IDU or supply air registers is reduced.

Enhanced operating efficiency

Raising superheat reduces refrigerant volume flowing through the coil. As flow decreases, demand on the compressor decreases and the compressor speed will be reduced, thus saving energy.

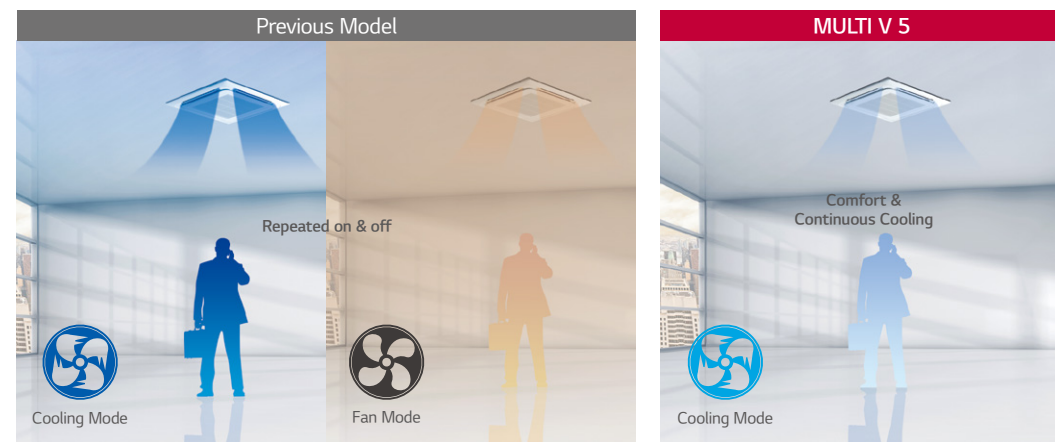

* Indoor unit set up available with Standard III Remote Controller

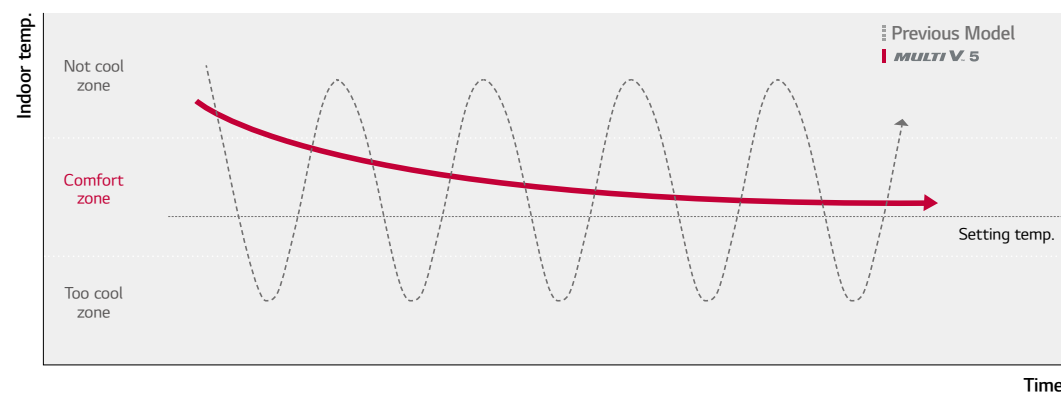

Intelligent Defrost

Increased heating run-hours

MULTI V 5 provides the same user selected defrost mode and method provided by LG's Intelligent Defrost based on current outdoor ambient temperature. With the addition of the outdoor air humidity sensor, MULTI V 5 Intelligent Defrost just got smarter. MULTI V 5 computes the current ambient air dew point temperature - the temperature at which frost will form on the outdoor unit coil in winter operation. MULTI V 5 makes continuous adjustments to the refrigeration cycle operating parameters to keep the outdoor coil surface temperature above actual dew point which can be calculated by using dry bulb Temp. and relative humidity. When the refrigeration cycle operating parameters can be adjusted no further without sacrificing heating comfort, further adjustment is stopped and frost is allowed to build on the coil.

What are the benefits?

The Intelligent Defrost algorithm increases the VRF system's heating run-hours and reduces the number of defrost cycles required to maintain optimum heating performance irrelevant of the mode and method of defrost selected.

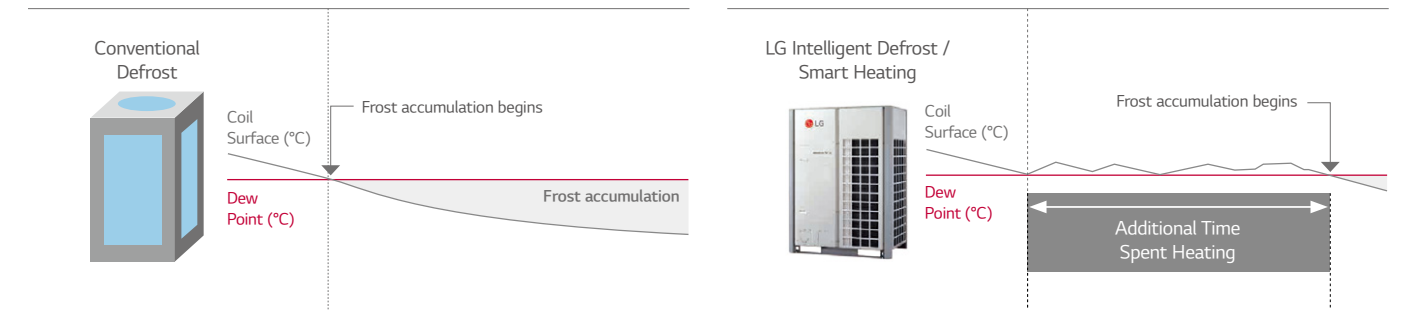

Increased heating operation time per day : Up to 17%
 • LG Internal Test result,
 • Test condition (MULTI V 5 vs MULTI V IV, 22HP)
 - Outdoor : 2/1°C , Indoor : 20/15°C - Humidity : 83%, Dew Point : -0.5°C

HiPOR™

Maximized reliability & efficiency of compressor

HiPOR™ is a trademark for LG's High Performance Oil Return apparatus. It consists of an oil separator, oil drain line between the separator and the compressor. HiPOR™ technology enables oil to return directly into the compressor, instead of returning through the refrigerant suction pipe. This does not waste energy when oil flows between the separator and the compressor. Because the operating pressure in the chamber containing the oil sump of the compressor and the pressure in the oil separator are nearly equal, there is no loss in compressor efficiency.

What are the benefits?

Maximizes reliability and efficiency of the compressor

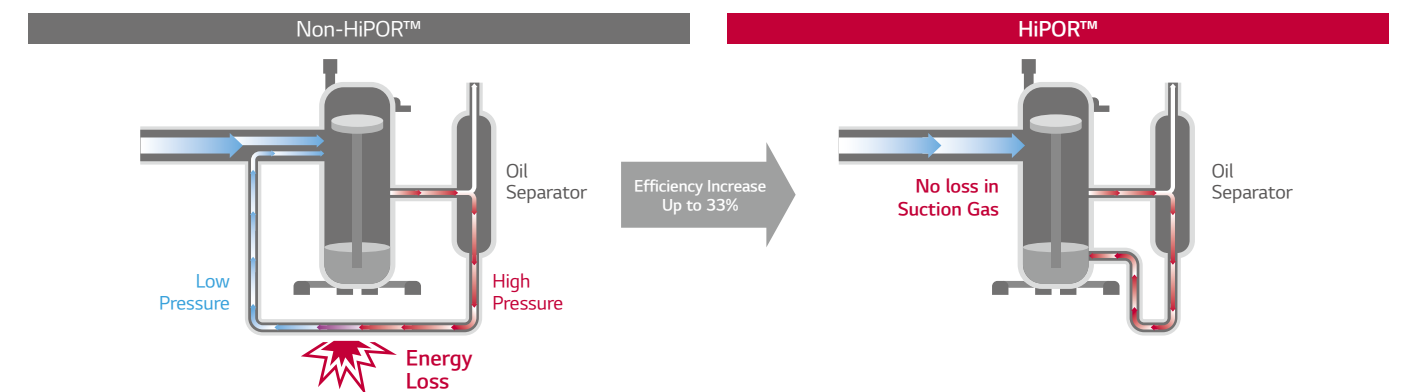

• LG Internal Test result,
 • Test condition - 15Hz Rating Condition : TC = 37.9°C , Te : 7.2°C

MULTI V 5

Smart Oil Management

Energy saving, Enhanced heating & increased compressor reliability

MULTI V 5 performs oil return on an as needed basis under normal operating conditions. An oil level sensor is provided in every LG VRF compressor. If the sensor indicates the compressor oil level is low, the main system processor is notified that an oil return cycle is necessary. Oil balancing cycle occurs every hour and does not hamper system performance. It balances the oil level deposit between both compressors in multi-compressor frames. Older VRF technology protects compressors from oil loss based on timed oil return logic because there was no way to know if the oil level in any one compressor was low. LG's unique oil level measuring sensor actively monitors the oil level in each compressor.

What are the benefits?

Energy savings compared with other systems. Fewer oil return cycles eliminates unnecessary energy consumption. Increases system heating run-time during winter operation. Increases compressor reliability.

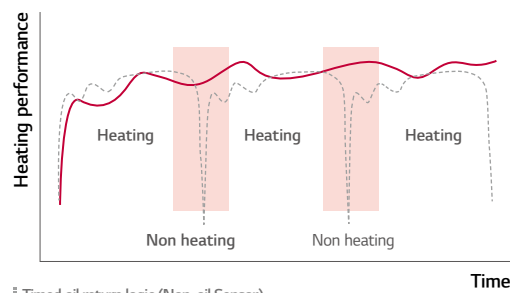

Timed oil return logic (Non_oil Sensor)
MULTI V. 5

- Increased heating operation time per day : Up to 12%
- LG Internal Test result,
- Test condition
- without oil level sensor : every 8hour oil recovery operation
- with oil level sensor : non oil recovery operation

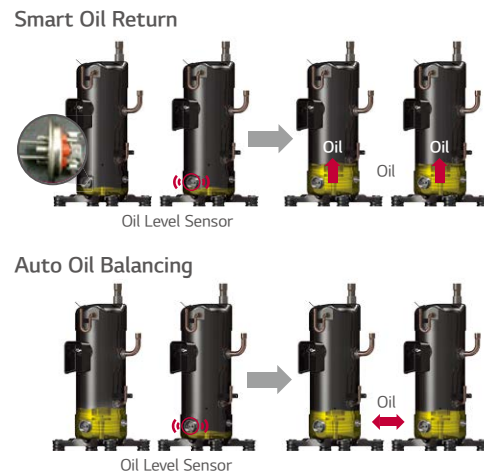

Sub-cooling & Vapor Injection

Increased heating performance

MULTI V 5 is equipped with advanced sub-cooler and vapor injection control system. The sub-cooler algorithm sub-cools liquid refrigerant just enough so that it can travel to the farthest IDU in the system operating in cooling mode without changing state. During low ambient operation down to -25°C, the sub-cooler provides medium temperature refrigerant gas to the compressor's vapor injection system. When injected into the compression chamber, system mass flow increases which stabilizes the system's suction pressure. In all cases the vapor injection increases the compressors cycle efficiency and reduces operating cost.

What are the benefits?

Provides stable refrigeration cycle operation over a wide range of outdoor ambient operating conditions. Increases compressor efficiency when compared to systems without vapor injection technology.

Technology Mechanism

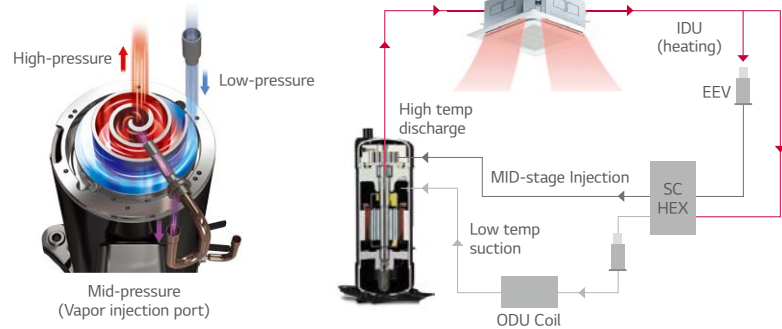

Performance Comparison

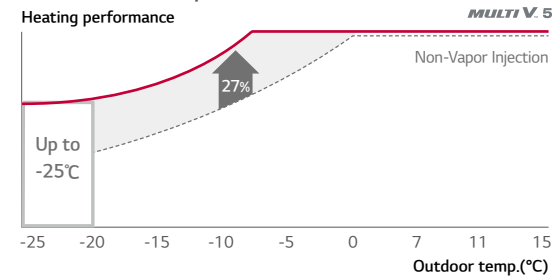

* Improved heating performance by 27%
* Comparison tested on 10HP model

Ocean Black Fin

Improved durability

The black coating with enhanced epoxy resin is applied for strong protection from various corrosive external conditions such as salt contamination and air pollution including fumes from factories. Moreover, the hydrophilic film keeps water from accumulating on the heat exchanger's fin, minimizing moisture buildup and eventually making it even more corrosion resistant. LG Corrosion Resistance solution passed ISO accelerated corrosion test conducted by an independent test organization and the result has been certified by prestigious global certification organization, UL (Underwriters Laboratories).

What are the benefits?

This improvement in durability prolongs the product's lifespan and lowers both the operational and maintenance costs.

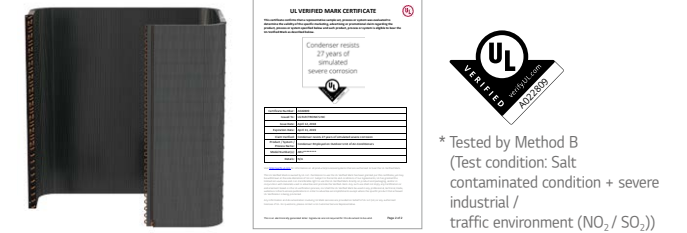
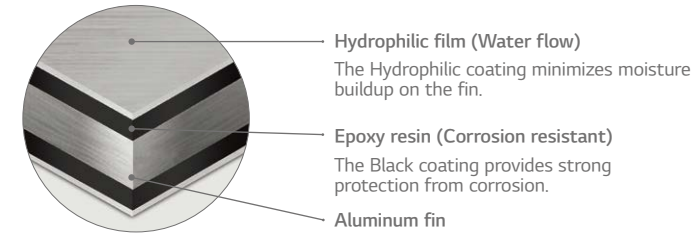

Condition of salt spray test

Temperature	35°C
Mist of 5% NaCl (mass fraction) solution	

Condition of gas exposure test

Temp.	Relative Humidity	Gas Volume Fraction	
		NO ₂	SO ₂
25°C	95%	10 x 10 ⁻⁶	5 x 10 ⁻⁶

Biomimetic Fan

Maximized performance

MULTI V 5 outdoor units fans have been upgraded. The moire pattern from external texture of clam shells has been applied on fans to create the range difference that results in reduction of noise level. At the same time, unlike the fans installed in previous products that generate separation of flow due to absence of tubercles, the bumpy back design inspired by the bumps on the humpback whale's flipper is applied as the tubercles on the back side of the fans, increasing wind power by reducing flacking. In addition to the biomimetic technology-based fans, extended shroud of MULTI V 5 allows more high static pressure and helps fans to blow higher air volume for efficient operation. With wider air guide, discharged air current is stabilized and noise level is reduced.

What are the benefits?

Based on the biomimetic technology, the fans of MULTI V 5 increased air flow rate by 10% in comparison to previous model and reduced its power consumption up to 20% when compared with the fan blade design on MULTI V IV. This eventually results in maximized performance with large capacity.



Air Flow Rate

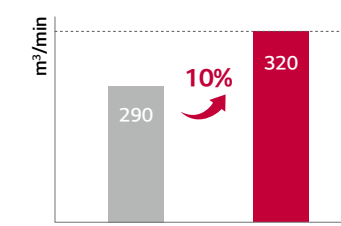

* Comparison based on 20HP model

Power Consumption

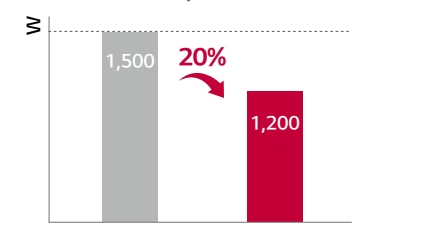

* Comparison based on air volume of 290m³/min

MULTI V 5

One Unified Model

Heat pump / Heat recovery with one platform

LG MULTI V 5 satisfies users' various needs with just one platform. Heat Pump System works for the sites where either cooling or heating operation is needed, while Heat Recovery System fits perfectly to the sites wherein both the cooling and heating operations are simultaneously needed or locations installed with Hot Water Solution to provide hot water and heating via radiator. By providing suitable solutions that cater to any building types and their requirements, MULTI V 5 offers the best HVAC system.

What are the benefits?

MULTI V 5 allows the building previously installed with Heat Pump System to switch to the Heat Recovery System for changing purpose of the building or remodeling reasons via simple piping construction.

Heat Pump System

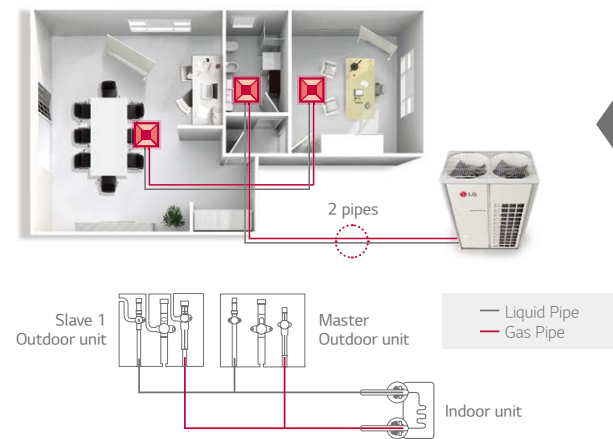

Heat Recovery System

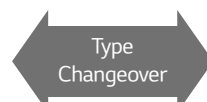
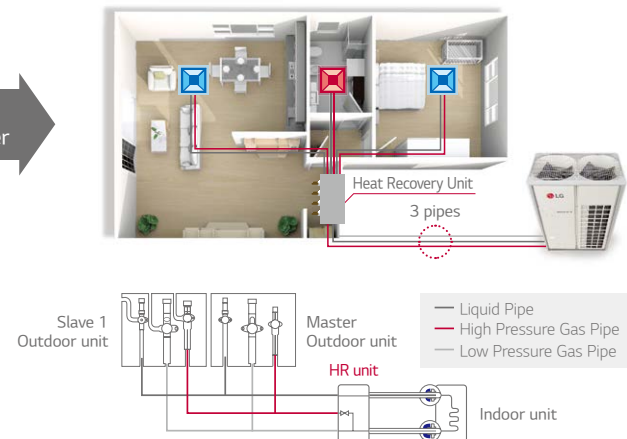

Wider Operation Range

Able to operate at extreme conditions

With enhanced inverter compressor and control technology coming from improved inverter cooling technology, sub-cooling and vapor injection, MULTI V 5 extended range of cooling and heating operations. For heating, it can operate at as low as -25°C to perform properly even at very cold environment. It is improved perfectly to fully function at extreme conditions such as performing cooling operation at -15°C, making the product adequate for uses in specialized venues like technical rooms. Moreover, MULTI V 5's cycle technology with enhanced durability enables optimal cooling performance at high temperature that increases up to 48°C.

Non TROPICAL MODEL

Heating

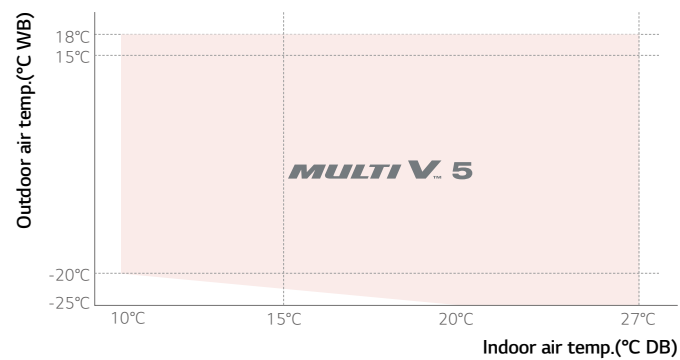

Cooling

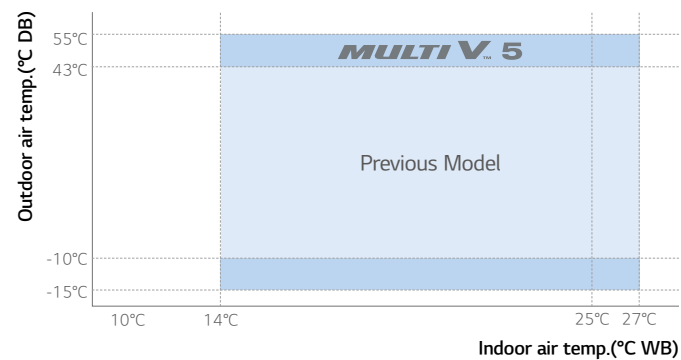

TROPICAL MODEL

Heating

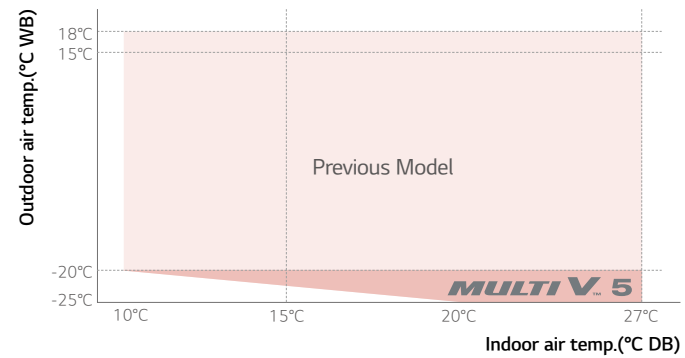

Cooling

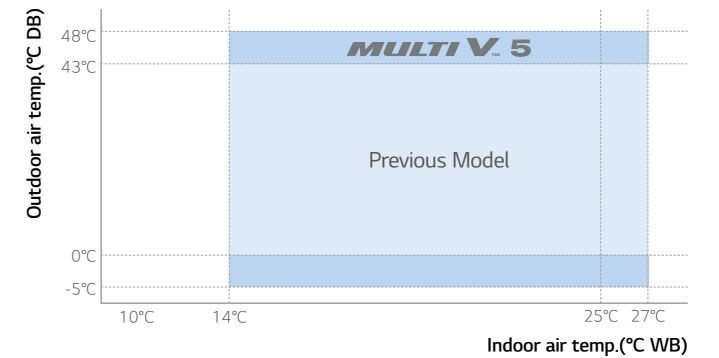

※ If it is not Tropical Model, please refer to the product spec sheet.

Simple Test Run via LGMV

Increased overall efficiency in installation

To make sure that the product functions properly, conducting a test run is recommended. For previous product, professional engineer who is wellaware of more than 40 different functional settings and more than 200 error codes had to check main parts in order to make sure that the test run had succeeded. With Mobile LGMV of MULTI V 5, fast and accurate auto test run can be executed and the professional installer running the test can receive test results via email, which shortens installation hours and increases overall efficiency in installation processes.

Previous



MULTI V 5



Wi-Fi MV Module

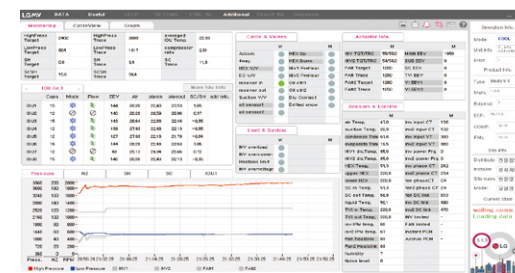

LGMV

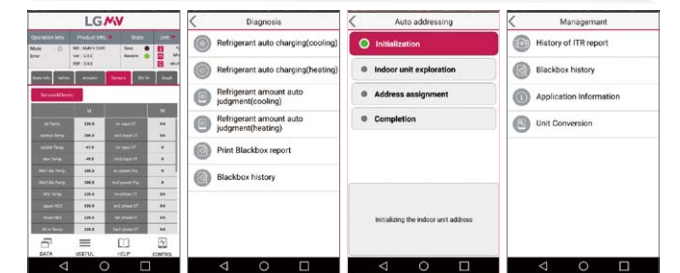

Cycle Monitoring Diagnosis Installation Smart Management

MULTI V 5

Outside Units Function

Category	Functions	MULTI V 5				
		Non-Tropical		Tropical		
		High Efficiency	Standard	High Efficiency	Standard	
Key Refrigerant components	Variable Path of Outdoor Units HEX	○	-	-	-	
	HiPOR™ (High Pressure Oil Return)	○	○	○	○	
	Humidity Sensor	○	○	○	○	
	Anti Corrosion Black Fin	○	○	○	○	
	Oil Sensor	○	○	○	○*	
Useful Function	Dual Sensing	○	○	○	○	
	Low Noise Operation	○	○	○	○	
	High Static Mode of Outdoor Units Fan	○	○	○	○	
	Partial Defrosting	○	-	-	-	
	Auto Dust Cleaning of Outdoor Units (Fan Reverse Rotation)	○	○	○	○	
	Indoor Cooling Comfort Mode Based Outdoor Temperature	○	○	○	○	
	Smart Load Control (SLC) (Changing Indoor Discharge Air Temperature According to Load)	○	○	○	○	
Reliability	Outdoor Unit Control Refer to Humidity	○	○	○	○	
	Defrost / Deicing	○	○	○	○	
	High Pressure Switch	○	○	○	○	
	Phase Protection	○	○	○	○	
	Restart Delay (3-minutes)	○	○	○	○	
	Self Diagnosis	○	○	○	○	
	Soft Start	○	○	○	○	
	Test Run Function	○	○	○	○	
	Central Controller	AC Ez (Simple Controller)	PQCSZ250S0	PQCSZ250S0	PQCSZ250S0	PQCSZ250S0
		AC Ez Touch	PACEZA000	PACEZA000	PACEZA000	PACEZA000
AC Smart IV		PACS4B000	PACS4B000	PACS4B000	PACS4B000	
AC Smart 5		PACS5A000	PACS5A000	PACS5A000	PACS5A000	
ACP (Advanced Control Platform) IV		PACP4B000	PACP4B000	PACP4B000	PACP4B000	
ACP (Advanced Control Platform) 5		PACP5A000	PACP5A000	PACP5A000	PACP5A000	
AC Manager 5		PACM5A000	PACM5A000	PACM5A000	PACM5A000	
BNU (Building Network Unit)	ACP Lonworks	PLNWKB000	PLNWKB000	PLNWKB000	PLNWKB000	
	ACP BACnet	PQNFB17C0	PQNFB17C0	PQNFB17C0	PQNFB17C0	
Installation	Refrigerant Charging Kit	PRAC1	PRAC1	PRAC1	PRAC1	
	Variable Water Flow Valve Control Kit	-	-	-	-	
PDI (Power Distribution Indicator)	Standard	PPWRDB000	PPWRDB000	PPWRDB000	PPWRDB000	
	Premium	PQNUD1S40	PQNUD1S40	PQNUD1S40	PQNUD1S40	
Cool / Heat Selector		PRDSBM	PRDSBM	PRDSBM	PRDSBM	
Low Ambient Kit		PRVC2	PRVC2	PRVC2	PRVC2	
IO Module (ODU Dry Contact)		PVDSMN000	PVDSMN000	PVDSMN000	PVDSMN000	
Cycle Monitoring Device	LGMV	PRCTILO	PRCTILO	PRCTILO	PRCTILO	
	Mobile LGMV	PLGMVW100	PLGMVW100	PLGMVW100	PLGMVW100	

Note
 ○ : Product internal function, - : Not applied
 Option: Refer to model name in table
 * 8HP, 10HP Models are without oil sensor

Dimension

ARUM080LTE5 / ARUM100LTE5 / ARUM120LTE5

[Unit : mm]

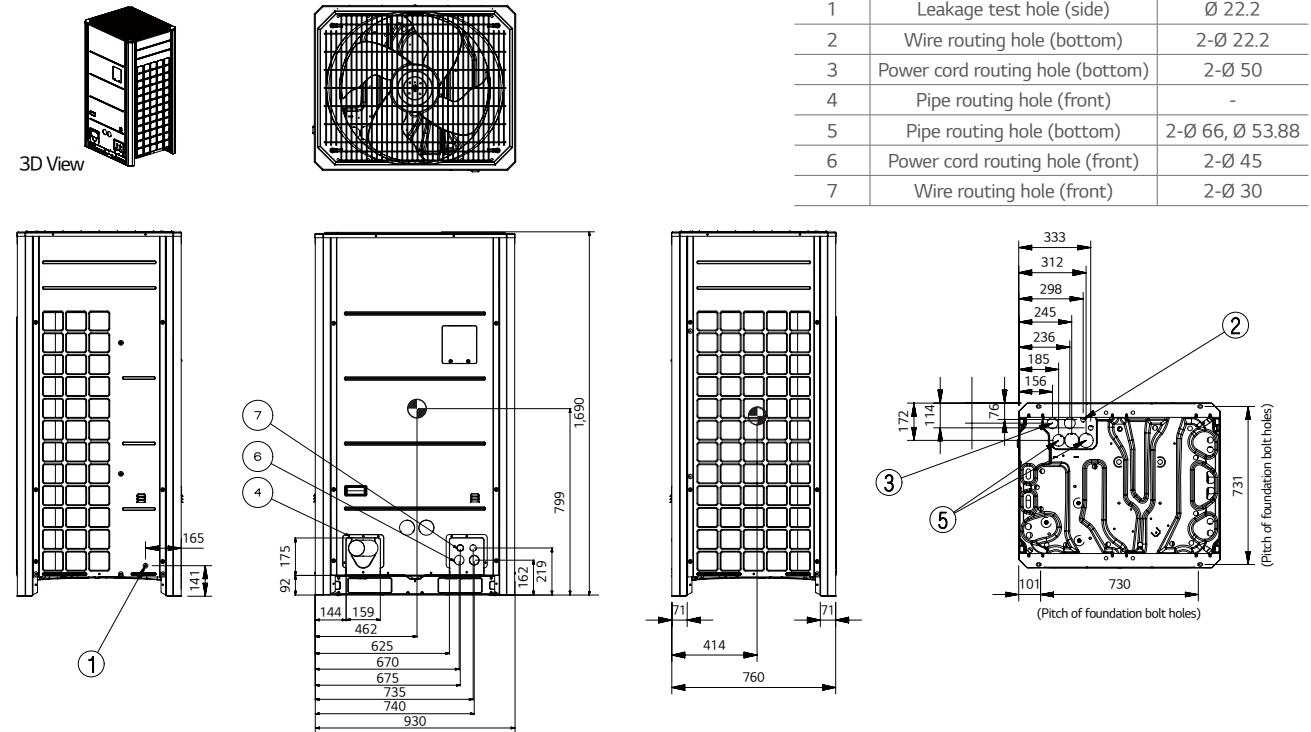

ARUM140LTE5 / ARUM160LTE5 / ARUM180LTE5 / ARUM200LTE5 / ARUM220LTE5 / ARUM240LTE5 / ARUM260LTE5

[Unit : mm]

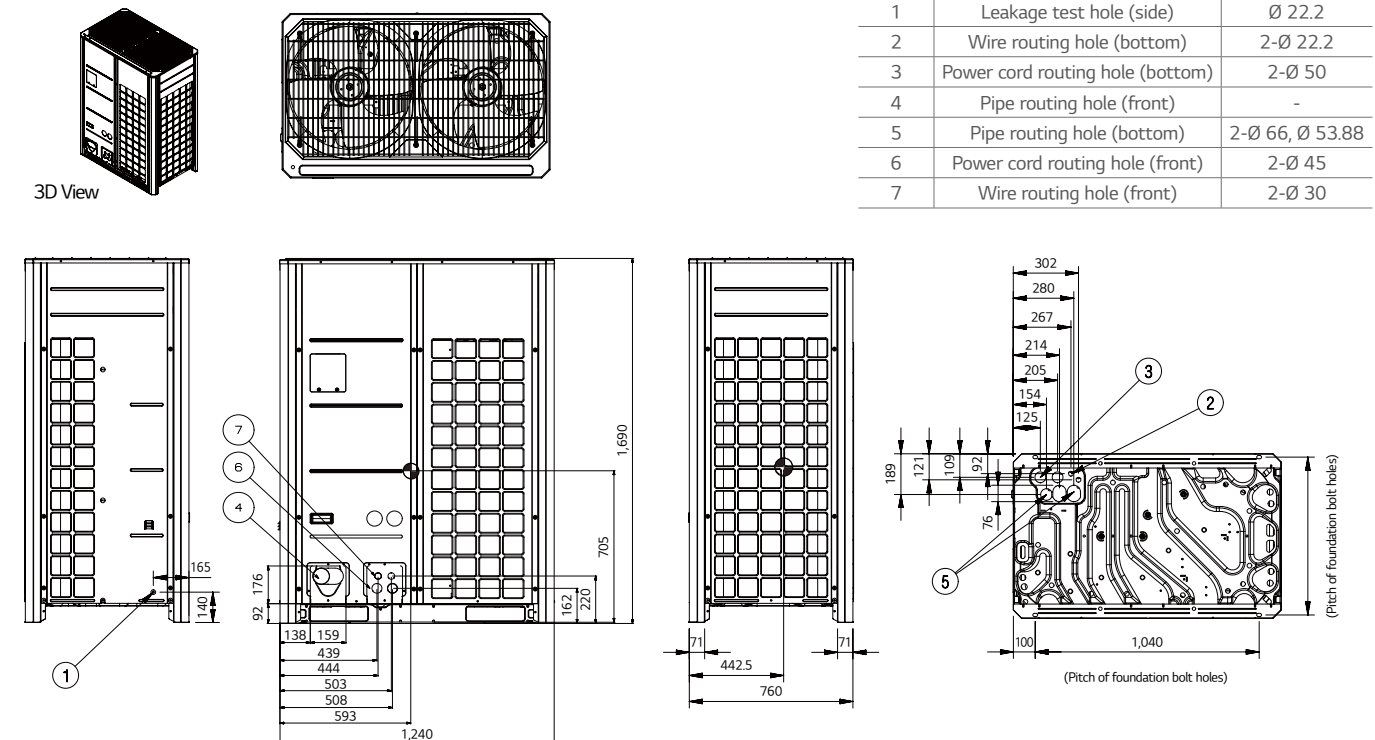

MULTI V 5

Wider Operation Range

Simultaneous Cooling / Heating Operation

Cooling

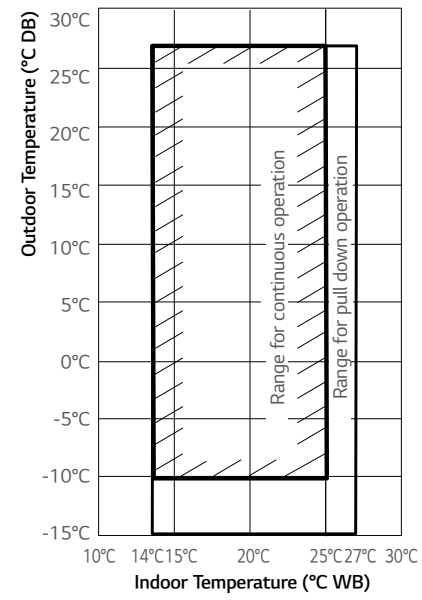

Heating

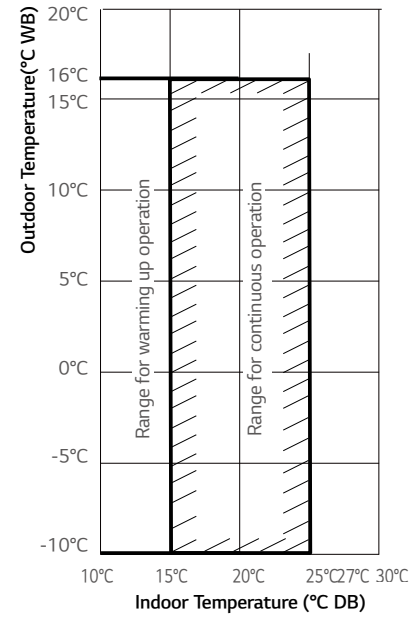

Note

1. These figures assume the following operating conditions : Equivalent piping length : 7.5m
Level difference : 0m
2. Range of pull down operation : If the relative humidity is too high, cooling capacity can be decreased by the sensible heat reduction.

MULTI V 5

Q1 What is the differences between MULTI V 5 Function by region?

A1 The portion of cooling operation hours at low humidity condition (below 50% RH) is big. The cooling load of this condition is less than the load at standard(50~70% RH) or high(over 70% RH) humidity condition even in the same outdoor air temperature. MULTI V 5 raises the evaporating Temp. up at low load(low humidity) condition to enable energy saving and prevent over-cooling which can happen when the system is controlled only by using outdoor air Temp.

Category	MULTI V IV H/P (ARUN***LTE4)	MULTI V 5 H/P & H/R (ARUM***LTE5)
Vapor Injection	○	○
HiPOR™	○	○
Smart Oil Control (Oil Level Sensor)	○	○
Active Refrigerant Control	○	○
Variable Heat Exchanger Circuit	○	○
Continuous Heating	○	○
Smart Load Control	○	○
Dual sensing (humidity sensor)	-	○
Comfort Cooling	○	○
Ocean Black Fin	-	○
Maximum Capacity (1 Unit / 4 Unit)	20 HP / 80 HP	26 HP / 96 HP
Height Difference (ODU - IDU / IDU - IDU)	110m / 40m	110m / 40m
Cooling Operating range(OAT, °CDB)	-10 ~ 43	-15 ~ 48
Heating Operating range(OAT, °CWB)	-25 ~ 18	-25 ~ 18
Combination ratio of IDU	1 Unit	50 ~ 200%
	2 Unit	50 ~ 160%
	3 or 4 Units	50 ~ 130%

Q2 Can MULTI V 5 ODU be connected with the 2 series indoor unit?

A2 Yes, MULTI V 5 ODU can be connected with the 2 series indoor unit. In this case, the ODU DIP Switch No.3 should be "OFF" which is default setting. Refer to the below table.

ODU	IDU	Compatibility	ODU DIP Switch No. 3	If dip switch setting is not correct	Ref.
Multi V IV Multi V 5	Gen. 2 (ARNU*2)	○	Must be OFF (factory default)	Can not communicate between Indoor & Outdoor unit (System will not be operated)	
	Gen. 4 (ARNU*4)	○	Must be ON to enable gen. 4 functions	When Dip Switch No. 3 is OFF, System can be operated, but some function of Gen. 4 is not available	
	Gen. 2 + Gen. 4	○	Must be OFF (factory default)	When Dip Switch No. 3 is ON, Can not communicate between Gen. 2 Indoor & Outdoor unit (Gen 2 units are not operated), only Gen 4 Units are operated.	Some function of Gen. 4 is not available

ODU dip switch setting procedure (No.3)

ODU main PCB dip switch is all "OFF" at default state

(1) Check and make sure that all connected indoor units are 4 series. (ARNU*****4.)

(2) Change Dip switch No. 3 from OFF → ON

(3) Push the reset button.

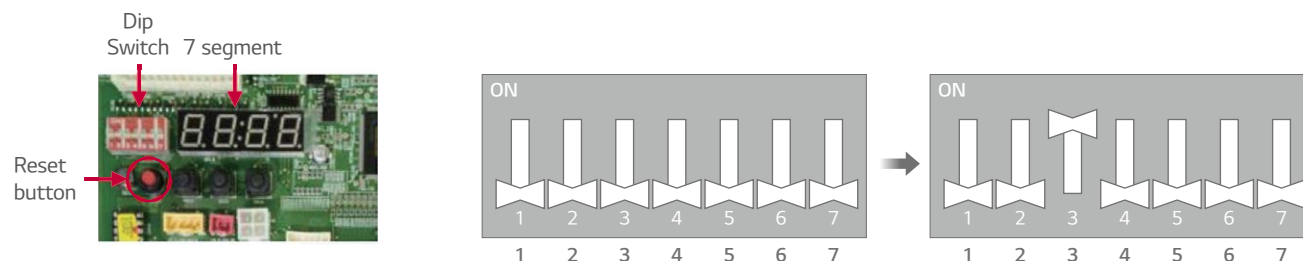

Q3 How does MULTI V 5 operate when humidity reference of the dual sensing SLC is that of the outdoor?

A3 During dual sensing SLC, outdoor unit changes target pressure of the system referring to temperature and humidity in cooling mode.

- When the humidity of outdoor side is higher than that of indoor side, outdoor unit will lower target pressure to remove humidity, thus outdoor unit will consume more energy and indoor will be more cooled compared to SLC operation but more efficiency than normal operation

Outdoor humidity is higher than indoor units

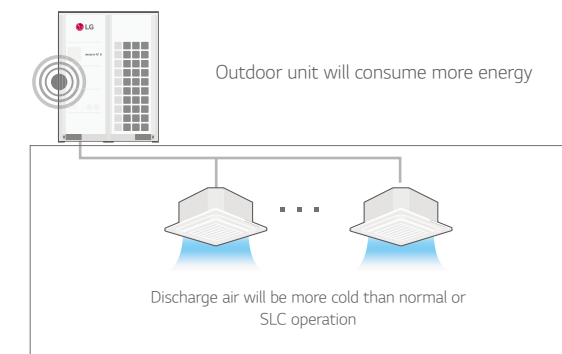

Evaporation temperature & efficiency

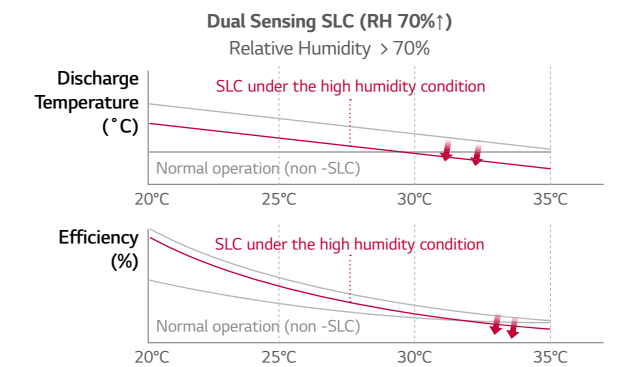

- When the humidity of outdoor side is lower than that of indoor side, outdoor unit will rise target pressure to save energy and keep comfort, but indoor humidity will be less removed compared to normal operation.

Outdoor humidity is lower than indoor units

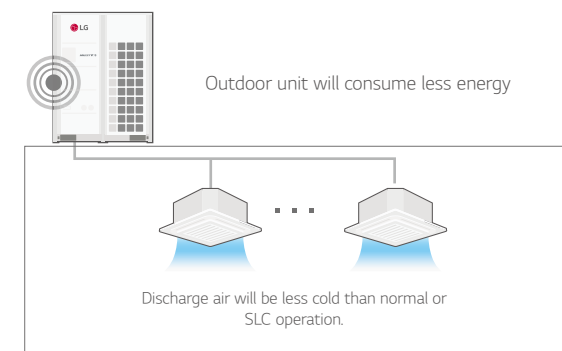

Evaporation temperature & efficiency

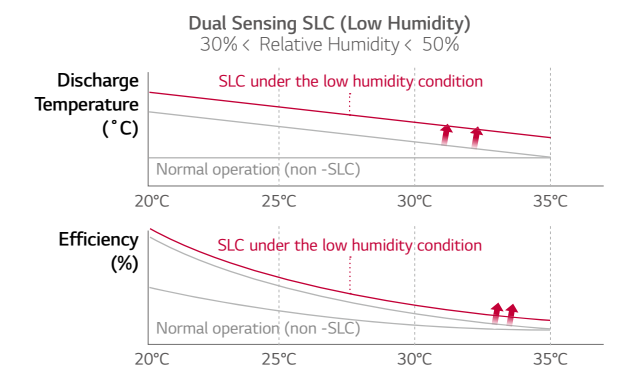

To keep comfort and save energy you may turn off outdoor units humidity sensing or propose to install new standard remote controller in order to sensing indoor humidity.

Sensing point

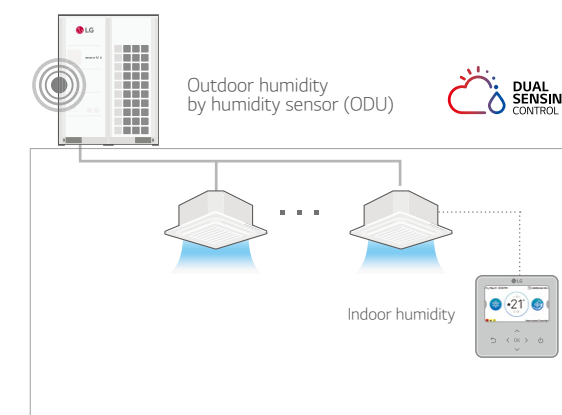

SLC Setting

CASE 1. Dual Sensing SLC with Outdoor humidity sensor in ODU Setting

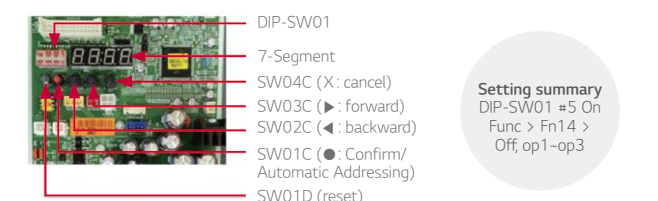

CASE 2. Dual Sensing SLC with Indoor humidity sensor in New Standard R/C setting (PREMTB100)



NOTE : User can turn off humidity control in ODU Setting (humidity reference) <Setting summary> ODU DIP-SW01 #5 On > Func > Fn16 > Off

MULTI V 5

Q4 What is the principle and accuracy of humidity sensor?

A4 Total Tolerance(%) = Sensor measurement tolerance(%) + Location of sensor tolerance(%)

The capacitive measurement principle established and proved itself as a standard in the past. For this principle, the sensor element is built out of a capacitor. The dielectric is a polymer which absorbs or releases water proportional to the relative environmental humidity, and thus changes the capacitance of the capacitor. This change in capacitance can be measured by an electronic circuit. For humidity sensors with CMOSens® technology, a “micro-machined” finger electrode system with different protective and polymer cover layers forms the capacitance for the sensor chip, and, in addition to providing the sensor property, simultaneously protects the sensor from interference in ways previously not achieved.

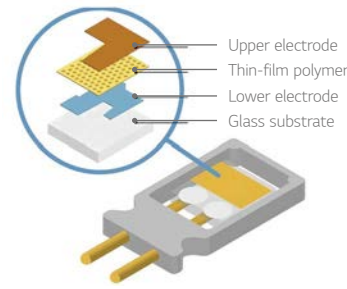

Model	Humidity Sensor of Outdoor	Humidity Sensor of R/Controller
Size (mm)	3 x 3 x 1.1	2.5 x 2.5 x 0.9
Supply voltage range	2.1 to 3.6 V	2.4 to 5.5 V
RH operating range	0 - 100% RH	0 - 100% RH
T operating range	-40 to +125°C (-40 to +257°F)	-40 to +125°C (-40 to +257°F)
RH response time	8 sec (tau 63%)	8 sec (tau 63%)

Q5 What is difference in refrigerant piping connection between MULTI V IV and MULTI V 5

A5 From MV 5, Low pressure gas pipe in heat pump operation changes to high pressure gas pipe in heat recovery operation due to internal cycle. So for heat pump cycle, no. 1, 3 pipe should be connected and for heat recovery operation, No. 1,2,3 pipe is connected. (For the heat pump operation, DO NOT connect No.2 pipe)

* Only for applied ARUMXXXLTES

Heat Recovery Installation

8HP	9.52	19.05	15.88
10HP	9.52	22.2	19.05
20HP	15.88	28.58	22.2

Heat Pump Installation

8HP	9.52	No Use	19.05
10HP	9.52	No Use	22.2
20HP	15.88	No Use	28.58

Reducer for Gas Pipe

15.88	→	19.05
19.05	→	22.2
22.2	→	28.58

※ For using as Heat Pump, Reducer for Gas pipe should be used. Reducer is included in outdoor unit.

Other Questions

Item	Question	Answer
Fan	The static pressure of MULTI V 5 is Max. 8 mmAq as MULTI V IV??	Yes, the static pressure of MULTI V 5 is the same with MULTI V IV.
Compressor	Is the limitation of Compressor max. Hz applied by the capacity of outdoor unit?	No, the limitation of comp Hz is not applied for default. But, it can be set by option for limitation of max Hz (or current).
4Way V/V	The usage of main & sub 4 way valve for MULTI V 5 ?	MULTI V 5 has the function of both H/P and H/R by one unit. Main valve has a function to change the operation mode. (cooling ↔ heating) Sub. Valve has a functions to change the product type (H/P ↔ H/R)
VI	In case of vapor injection, how much is the middle pressure?	The optimal middle pressure for vapor injection is 1.2 PS. PS : Suction pressure of compressor
VI	By how much is heating capacity increased by vapor injection?	Generally, the heating capacity is increased up to 15~20%.
Humidity Sensor	Where is Indoor Humidity sensor?	It is placed inside of the RS3 remote controller.
Remote Controller	Does remote controller show the humidity information (status) as well?	Yes. It shows the current humidity information on screen. (for RS3 Only) But has no function to control the humidity
Remote Controller	Is it possible to connect the local humidity sensor with Remote controller (RS3)?	No. All of RS3 remote controller can not be connected with local humidity sensor.
SLC	Does dual sensing SLC function control the humidity ratio?	No. There is no control of humidity ratio.
SLC	Is SLC fully used on Eurovent? Isn't humidity fixed for the test? What about AHRI?	Eurovent (RH 47%) and AHRI (RH 51%) have fixed humidity test condition.
Comfort Cooling	Why is not the comfort heating applied in product?	Comfort cooling need super heating controlled and Comfort heating need sub cooling controlled. In case of controlling EEV for sub cooling, noise and stable operation may be affected and critical.
Installation	Does the IDU – Central controller direct connection for communication cable is possible? (Flat connection)	No, it is not possible.

MULTI V 5

Non TROPICAL MODEL

HIGH EFFICIENCY

ARUM080LTE5 / ARUM100LTE5 / ARUM120LTE5 / ARUM140LTE5 / ARUM160LTE5

LG participates in the ECP programme for EUROVENT VRF program. Check ongoing validity of certification : www.eurovent-certification.com



HP			8	10	12	14	16
Model Name	Combination Unit		ARUM080LTE5	ARUM100LTE5	ARUM120LTE5	ARUM140LTE5	ARUM160LTE5
	Independent Unit		ARUM080LTE5	ARUM100LTE5	ARUM120LTE5	ARUM140LTE5	ARUM160LTE5
Capacity	Cooling (Rated)	kW	22.4	28.0	33.6	39.2	44.8
	Heating (Rated)	kW	22.4	28.0	33.6	39.2	44.8
	Heating (Max)	kW	25.2	31.5	37.8	44.1	50.4
Input	Cooling (Rated)	kW	4.49	5.80	7.58	8.68	10.89
	Heating (Rated)	kW	3.97	4.92	6.85	8.13	10.28
	Heating (Max)	kW	4.78	5.92	8.26	9.72	12.39
EER		4.99	4.83	4.43	4.52	4.11	
ESEER		8.41	8.13	7.47	7.33	6.59	
ESEER (SLC)		9.46	9.15	8.60	8.26	7.79	
COP	COP (Rated)		5.64	5.69	4.91	4.82	4.36
	COP (Max)		5.27	5.32	4.58	4.54	4.07
Casing Color		Warm Gray / Dawn Gray	Warm Gray / Dawn Gray	Warm Gray / Dawn Gray	Warm Gray / Dawn Gray	Warm Gray / Dawn Gray	
Heat Exchanger		Ocean Black Fin	Ocean Black Fin	Ocean Black Fin	Ocean Black Fin	Ocean Black Fin	
Compressor	Motor Output x Number	W x No.	4,200 x 1	5,300 x 1	5,300 x 1	5,300 x 1	5,300 x 1
	Type		Propeller fan	Propeller fan	Propeller fan	Propeller fan	Propeller fan
Fan	Air Flow Rate (High)	m ³ /min	240 x 1	240 x 1	240 x 1	320 x 1	320 x 1
	Drive		DC INVERTER	DC INVERTER	DC INVERTER	DC INVERTER	DC INVERTER
	Liquid Pipe	mm(inch)	9.52(3/8)	9.52(3/8)	12.7(1/2)	12.7(1/2)	12.7(1/2)
Low Pressure Gas Pipe	mm(inch)	19.05(3/4)	22.2(7/8)	28.58(1-1/8)	28.58(1-1/8)	28.58(1-1/8)	
High Pressure Gas Pipe	mm(inch)	15.88(5/8)	19.05(3/4)	19.05(3/4)	22.2(7/8)	22.2(7/8)	
Dimensions (W x H x D)	mm	(930 x 1,690 x 760) x 1	(930 x 1,690 x 760) x 1	(930 x 1,690 x 760) x 1	(1,240 x 1,690 x 760)x1	(1,240 x 1,690 x 760)x1	
Net Weight	kg	198 x 1	215 x 1	215 x 1	237 x 1	237 x 1	
Sound Pressure Level	Cooling	dB(A)	58.0	58.0	59.0	60.0	60.5
	Heating	dB(A)	59.0	59.0	60.0	61.0	61.5
Sound Power Level	Cooling	dB(A)	84.0	85.0	86.0	89.0	90.0
	Heating	dB(A)	87.0	88.0	89.0	93.0	94.0
Communication Cable	No. x mm ² (VCTF-SB)	2C x 1.0 - 1.5	2C x 1.0 - 1.5	2C x 1.0 - 1.5	2C x 1.0 - 1.5	2C x 1.0 - 1.5	
Refrigerant	Refrigerant Name		R410A	R410A	R410A	R410A	R410A
	Precharged Amount in factory	kg	7.5	9.5	9.5	13.5	13.5
		lbs	16.5	20.9	20.9	29.8	29.8
	GWP		2087.5	2087.5	2087.5	2087.5	2087.5
	t-CO ₂ eq		15.7	19.8	19.8	28.2	28.2
Control		Electronic Expansion Valve	Electronic Expansion Valve	Electronic Expansion Valve	Electronic Expansion Valve	Electronic Expansion Valve	
Refrigerant Oil	Type		FVC68D(PVE)	FVC68D(PVE)	FVC68D(PVE)	FVC68D(PVE)	FVC68D(PVE)
	Charge	cc	3,900	3,900	3,900	3,900	3,900
Power Supply		∅, V, Hz	380-415, 3, 50	380-415, 3, 50	380-415, 3, 50	380-415, 3, 50	380-415, 3, 50
			380, 3, 60	380, 3, 60	380, 3, 60	380, 3, 60	380, 3, 60
Number of Maximum Connectable Indoor Units		13(20)	16(25)	20(30)	23(35)	26(40)	

* This product contains Fluorinated Greenhouse Gases. (R410A)

Non TROPICAL MODEL

HIGH EFFICIENCY

ARUM180LTE5 / ARUM200LTE5 / ARUM220LTE5
ARUM221LTE5 / ARUM240LTE5

LG participates in the ECP programme for EUROVENT VRF program. Check ongoing validity of certification : www.eurovent-certification.com



HP			18	20	22	22'	24
Model Name	Combination Unit		ARUM180LTE5	ARUM200LTE5	ARUM220LTE5	ARUM221LTE5	ARUM240LTE5
	Independent Unit		ARUM180LTE5	ARUM200LTE5	ARUM220LTE5	ARUM120LTE5 ARUM100LTE5	ARUM240LTE5
Capacity	Cooling (Rated)	kW	50.4	56.0	61.6	61.6	67.2
	Heating (Rated)	kW	50.4	56.0	61.6	61.6	67.2
	Heating (Max)	kW	56.7	63.0	69.3	69.3	74.3
Input		Btu/h	193,500	215,000	236,500	236,500	253,400
	Cooling (Rated)	kW	10.91	12.77	15.70	13.4	17.40
	Heating (Rated)	kW	10.12	12.20	14.15	11.8	15.89
	Heating (Max)	kW	11.94	14.69	16.76	14.2	18.80
EER		4.62	4.39	3.92	4.60	3.86	
ESEER		7.40	7.03	6.68	7.76	6.57	
ESEER (SLC)		8.11	7.70	7.87	8.84	8.05	
COP	COP (Rated)		4.98	4.59	4.35	5.23	4.23
	COP (Max)		4.75	4.29	4.13	4.89	3.95
Casing Color		Warm Gray / Dawn Gray	Warm Gray / Dawn Gray	Warm Gray / Dawn Gray	Warm Gray / Dawn Gray	Warm Gray / Dawn Gray	
Heat Exchanger		Ocean Black Fin	Ocean Black Fin	Ocean Black Fin	Ocean Black Fin	Ocean Black Fin	
Compressor	Motor Output x Number	W x No.	5,300 x 1 + 4,200 x 1	5,300 x 1 + 4,200 x 1	5,300 x 1 + 4,200 x 1	5,300 x 2	5,300 x 2
	Type		Propeller fan	Propeller fan	Propeller fan	Propeller fan	Propeller fan
Fan	Air Flow Rate (High)	m ³ /min	320 x 1	320 x 1	320 x 1	(240 x 1) + (240 x 1)	320 x 1
	Drive		DC INVERTER	DC INVERTER	DC INVERTER	DC INVERTER	DC INVERTER
	Liquid Pipe	mm(inch)	15.88(5/8)	15.88(5/8)	15.88(5/8)	15.88(5/8)	15.88(5/8)
Low Pressure Gas Pipe	mm(inch)	28.58(1-1/8)	28.58(1-1/8)	28.58(1-1/8)	28.58(1-1/8)	34.9(1-3/8)	
High Pressure Gas Pipe	mm(inch)	22.2(7/8)	22.2(7/8)	28.58(1-1/8)	28.58(1-1/8)	28.58(1-1/8)	
Dimensions (W x H x D)	mm	(1,240 x 1,690 x 760) x1	(1,240 x 1,690 x 760) x1	(1,240 x 1,690 x 760) x1	(930 x 1,690 x 760) x 1 + (930 x 1,690 x 760) x 1	(1,240 x 1,690 x 760) x1	
Net Weight	kg	300 x 1	300 x 1	300 x 1	(215 x 1) + (215 x 1)	310 x 1	
Sound Pressure Level	Cooling	dB(A)	61.0	62.0	64.5	61.5	65.0
	Heating	dB(A)	62.0	64.5	65.5	62.5	67.0
Sound Power Level	Cooling	dB(A)	92.0	93.0	93.0	88.5	95.0
	Heating	dB(A)	95.0	96.0	97.0	91.5	99.0
Communication Cable	No. x mm ² (VCTF-SB)	2C x 1.0 - 1.5	2C x 1.0 - 1.5	2C x 1.0 - 1.5	2C x 1.0 - 1.5	2C x 1.0 - 1.5	
Refrigerant	Refrigerant Name		R410A	R410A	R410A	R410A	R410A
	Precharged Amount in factory	kg	16.0	16.0	16.0	19.0	17.0
		lbs	35.3	35.3	35.3	41.9	37.5
	GWP		2087.5	2087.5	2087.5	2087.5	2087.5
	t-CO ₂ eq		33.4	33.4	33.4	39.7	35.5
Control		Electronic Expansion Valve	Electronic Expansion Valve	Electronic Expansion Valve	Electronic Expansion Valve	Electronic Expansion Valve	
Refrigerant Oil	Type		FVC68D(PVE)	FVC68D(PVE)	FVC68D(PVE)	FVC68D(PVE)	FVC68D(PVE)
	Charge	cc	5,200	5,200	5,200	7,800	5,200
Power Supply		∅, V, Hz	380-415, 3, 50	380-415, 3, 50	380-415, 3, 50	380-415, 3, 50	380-415, 3, 50
			380, 3, 60	380, 3, 60	380, 3, 60	380, 3, 60	380, 3, 60
Number of Maximum Connectable Indoor Units		29(45)	32(50)	35(44)	35(44)	39(48)	

* This product contains Fluorinated Greenhouse Gases. (R410A)

MULTI V 5

Non TROPICAL MODEL

HIGH EFFICIENCY

ARUM260LTE5 / ARUM241LTE5 / ARUM261LTE5
ARUM280LTE5 / ARUM300LTE5



LG participates in the ECP programme for EUROVENT VRF program.
Check ongoing validity of certification
: www.eurovent-certification.com

HP			24'	26	26'	28	30
Model Name	Combination Unit		ARUM241LTE5	ARUM260LTE5	ARUM261LTE5	ARUM280LTE5	ARUM300LTE5
	Independent Unit		ARUM120LTE5 ARUM120LTE5	ARUM260LTE5	ARUM140LTE5 ARUM120LTE5	ARUM160LTE5 ARUM120LTE5	ARUM180LTE5 ARUM120LTE5
Capacity	Cooling (Rated)	kW	67.2	72.8	72.8	78.4	84.0
	Heating (Rated)	kW	67.2	67.2	72.8	78.4	84.0
	Heating (Max)	kW	75.6	74.3	81.9	88.2	94.5
		Btu/h	257,900	253,400	279,400	300,900	322,400
Input	Cooling (Rated)	kW	15.2	20.20	16.3	18.5	18.5
	Heating (Rated)	kW	13.7	15.99	15.0	17.1	17.0
	Heating (Max)	kW	16.5	19.15	18.0	20.7	20.2
EER			4.43	3.60	4.48	4.24	4.54
ESEER			7.47	6.34	7.39	6.94	7.43
ESEER (SLC)			8.60	7.62	8.41	8.12	8.29
COP	COP (Rated)		4.91	4.20	4.86	4.58	4.95
	COP (Max)		4.58	3.88	4.56	4.27	4.68
Casing Color			Warm Gray / Dawn Gray	Warm Gray / Dawn Gray	Warm Gray / Dawn Gray	Warm Gray / Dawn Gray	Warm Gray / Dawn Gray
Heat Exchanger			Ocean Black Fin	Ocean Black Fin	Ocean Black Fin	Ocean Black Fin	Ocean Black Fin
Compressor	Motor Output x Number	W x No.	5,300 x 2	5,300 x 2	5,300 x 2	5,300 x 2	(5,300 x 2) + (4,200 x 1)
	Type		Propeller fan	Propeller fan	Propeller fan	Propeller fan	Propeller fan
Fan	Air Flow Rate (High)	m ³ /min	(240 x 1) + (240 x 1)	320 x 1	(320 x 1) + (240 x 1)	(320 x 1) + (240 x 1)	(320 x 1) + (240 x 1)
	Drive		DC INVERTER	DC INVERTER	DC INVERTER	DC INVERTER	DC INVERTER
	Liquid Pipe	mm(inch)	15.88(5/8)	19.05(3/4)	19.05(3/4)	19.05(3/4)	19.05(3/4)
Low Pressure Gas Pipe	mm(inch)	34.9(1-3/8)	34.9(1-3/8)	34.9(1-3/8)	34.9(1-3/8)	34.9(1-3/8)	
High Pressure Gas Pipe	mm(inch)	28.58(1-1/8)	28.58(1-1/8)	28.58(1-1/8)	28.58(1-1/8)	28.58(1-1/8)	
Dimensions (W x H x D)	mm	(930 x 1,690 x 760) x 1 + (930 x 1,690 x 760) x 1	(1,240 x 1,690 x 760) x 1	(1,240 x 1,690 x 760) x 1 + (930 x 1,690 x 760) x 1	(1,240 x 1,690 x 760) x 1 + (930 x 1,690 x 760) x 1	(1,240 x 1,690 x 760) x 1 + (930 x 1,690 x 760) x 1	(1,240 x 1,690 x 760) x 1 + (930 x 1,690 x 760) x 1
Net Weight	kg	(215 x 1) + (215 x 1)	310 x 1	(237 x 1) + (215 x 1)	(237 x 1) + (215 x 1)	(300 x 1) + (215 x 1)	
Sound Pressure Level	Cooling	dB(A)	62.0	65.0	62.5	62.8	63.1
	Heating	dB(A)	63.0	67.0	63.5	63.8	64.1
Sound Power Level	Cooling	dB(A)	89.0	95.0	90.8	91.5	93.0
	Heating	dB(A)	92.0	99.0	94.5	95.2	96.0
Communication Cable	No. x mm ² (VCTF-SB)		2C x 1.0 - 1.5	2C x 1.0 - 1.5	2C x 1.0 - 1.5	2C x 1.0 - 1.5	2C x 1.0 - 1.5
Refrigerant	Refrigerant Name		R410A	R410A	R410A	R410A	R410A
	Precharged Amount in factory	kg	19.0	17.0	23.0	23.0	25.5
		lbs	41.9	37.5	50.7	50.7	56.2
	GWP		2087.5	2087.5	2087.5	2087.5	2087.5
	t-CO ₂ eq		39.7	35.5	48.0	48.0	53.2
Control		Electronic Expansion Valve	Electronic Expansion Valve	Electronic Expansion Valve	Electronic Expansion Valve	Electronic Expansion Valve	
Refrigerant Oil	Type		FVC68D(PVE)	FVC68D(PVE)	FVC68D(PVE)	FVC68D(PVE)	FVC68D(PVE)
	Charge	cc	7,800	5,200	7,800	7,800	9,100
Power Supply	∅, V, Hz		380-415, 3, 50	380-415, 3, 50	380-415, 3, 50	380-415, 3, 50	380-415, 3, 50
			380, 3, 60	380, 3, 60	380, 3, 60	380, 3, 60	380, 3, 60
Number of Maximum Connectable Indoor Units			39(48)	42(52)	42(52)	45(56)	49(60)

* This product contains Fluorinated Greenhouse Gases. (R410A)

Non TROPICAL MODEL

HIGH EFFICIENCY

ARUM320LTE5 / ARUM340LTE5 / ARUM360LTE5
ARUM380LTE5 / ARUM400LTE5



HP			32	34	36	38	40
Model Name	Combination Unit		ARUM320LTE5	ARUM340LTE5	ARUM360LTE5	ARUM380LTE5	ARUM400LTE5
	Independent Unit		ARUM200LTE5 ARUM120LTE5	ARUM220LTE5 ARUM120LTE5	ARUM240LTE5 ARUM120LTE5	ARUM240LTE5 ARUM140LTE5	ARUM240LTE5 ARUM160LTE5
Capacity	Cooling (Rated)	kW	89.6	95.2	100.8	106.4	112.0
	Heating (Rated)	kW	89.6	95.2	100.8	106.4	112.0
	Heating (Max)	kW	100.8	107.1	112.1	118.4	124.7
		Btu/h	343,900	365,400	382,300	403,800	425,300
Input	Cooling (Rated)	kW	20.4	23.3	25.0	26.1	28.3
	Heating (Rated)	kW	19.1	21.0	22.7	24.0	26.2
	Heating (Max)	kW	22.9	25.0	27.1	28.5	31.2
EER			4.40	4.09	4.04	4.08	3.96
ESEER			7.19	6.94	6.85	6.83	6.58
ESEER (SLC)			8.01	8.11	8.22	8.11	7.94
COP	COP (Rated)		4.70	4.53	4.43	4.43	4.28
	COP (Max)		4.39	4.28	4.14	4.15	4.00
Casing Color			Warm Gray / Dawn Gray	Warm Gray / Dawn Gray	Warm Gray / Dawn Gray	Warm Gray / Dawn Gray	Warm Gray / Dawn Gray
Heat Exchanger			Ocean Black Fin	Ocean Black Fin	Ocean Black Fin	Ocean Black Fin	Ocean Black Fin
Compressor	Motor Output x Number	W x No.	(5,300 x 2) + (4,200 x 1)	(5,300 x 2) + (4,200 x 1)	5,300 x 3	5,300 x 3	5,300 x 3
	Type		Propeller fan	Propeller fan	Propeller fan	Propeller fan	Propeller fan
Fan	Air Flow Rate (High)	m ³ /min	(320 x 1) + (240 x 1)	(320 x 1) + (240 x 1)	(320 x 1) + (240 x 1)	320 x 2	320 x 2
	Drive		DC INVERTER	DC INVERTER	DC INVERTER	DC INVERTER	DC INVERTER
	Liquid Pipe	mm(inch)	19.05(3/4)	19.05(3/4)	19.05(3/4)	19.05(3/4)	19.05(3/4)
Low Pressure Gas Pipe	mm(inch)	34.9(1-3/8)	34.9(1-3/8)	41.3(1-5/8)	41.3(1-5/8)	41.3(1-5/8)	
High Pressure Gas Pipe	mm(inch)	28.58(1-1/8)	28.58(1-1/8)	28.58(1-1/8)	28.58(1-1/8)	28.58(1-1/8)	
Dimensions (W x H x D)	mm	(1,240 x 1,690 x 760) x 1 + (930 x 1,690 x 760) x 1	(1,240 x 1,690 x 760) x 1 + (930 x 1,690 x 760) x 1	(1,240 x 1,690 x 760) x 1 + (930 x 1,690 x 760) x 1	(1,240 x 1,690 x 760) x 1 + (930 x 1,690 x 760) x 1	(1,240 x 1,690 x 760) x 2	(1,240 x 1,690 x 760) x 2
Net Weight	kg	(300 x 1) + (215 x 1)	(300 x 1) + (215 x 1)	(310 x 1) + (215 x 1)	(310 x 1) + (237 x 1)	(310 x 1) + (237 x 1)	
Sound Pressure Level	Cooling	dB(A)	63.8	65.6	66.0	66.2	66.3
	Heating	dB(A)	65.8	66.6	67.8	68.0	68.1
Sound Power Level	Cooling	dB(A)	93.8	93.8	95.5	96.0	96.2
	Heating	dB(A)	96.8	97.6	99.4	100.0	100.2
Communication Cable	No. x mm ² (VCTF-SB)		2C x 1.0 - 1.5	2C x 1.0 - 1.5	2C x 1.0 - 1.5	2C x 1.0 - 1.5	2C x 1.0 - 1.5
Refrigerant	Refrigerant Name		R410A	R410A	R410A	R410A	R410A
	Precharged Amount in factory	kg	25.5	25.5	26.5	30.5	30.5
		lbs	56.2	56.2	58.4	67.2	67.2
	GWP		2087.5	2087.5	2087.5	2087.5	2087.5
	t-CO ₂ eq		53.2	53.2	55.3	63.7	63.7
Control		Electronic Expansion Valve	Electronic Expansion Valve	Electronic Expansion Valve	Electronic Expansion Valve	Electronic Expansion Valve	
Refrigerant Oil	Type		FVC68D(PVE)	FVC68D(PVE)	FVC68D(PVE)	FVC68D(PVE)	FVC68D(PVE)
	Charge	cc	9,100	9,100	9,100	9,100	9,100
Power Supply	∅, V, Hz		380-415, 3, 50	380-415, 3, 50	380-415, 3, 50	380-415, 3, 50	380-415, 3, 50
			380, 3, 60	380, 3, 60	380, 3, 60	380, 3, 60	380, 3, 60
Number of Maximum Connectable Indoor Units			52(64)	55(64)	58(64)	61(64)	64

* This product contains Fluorinated Greenhouse Gases. (R410A)

MULTI V 5

Non TROPICAL MODEL

HIGH EFFICIENCY

ARUM420LTE5 / ARUM440LTE5 / ARUM460LTE5
ARUM480LTE5 / ARUM500LTE5



HP			42	44	46	48	50
Model Name	Combination Unit		ARUM420LTE5	ARUM440LTE5	ARUM460LTE5	ARUM480LTE5	ARUM500LTE5
	Independent Unit		ARUM240LTE5 ARUM180LTE5	ARUM240LTE5 ARUM200LTE5	ARUM240LTE5 ARUM220LTE5	ARUM240LTE5 ARUM240LTE5	ARUM240LTE5 ARUM140LTE5 ARUM120LTE5
Capacity	Cooling (Rated)	kW	117.6	123.2	128.8	134.4	140.0
	Heating (Rated)	kW	117.6	123.2	128.8	134.4	140.0
	Heating (Max)	kW Btu/h	131.0 446,800	137.3 468,300	143.6 489,800	148.5 506,700	156.2 532,800
Input	Cooling (Rated)	kW	28.3	30.2	33.1	34.8	33.7
	Heating (Rated)	kW	26.0	28.1	30.0	31.8	30.9
	Heating (Max)	kW	30.7	33.5	35.6	37.6	36.8
EER			4.15	4.08	3.89	3.86	4.16
ESEER			6.90	6.77	6.62	6.57	6.97
ESEER (SLC)			8.05	7.86	7.96	8.05	8.23
COP	COP (Rated)		4.52	4.39	4.29	4.23	4.54
	COP (Max)		4.26	4.10	4.04	3.95	4.25
Casing Color			Warm Gray / Dawn Gray	Warm Gray / Dawn Gray	Warm Gray / Dawn Gray	Warm Gray / Dawn Gray	Warm Gray / Dawn Gray
Heat Exchanger			Ocean Black Fin	Ocean Black Fin	Ocean Black Fin	Ocean Black Fin	Ocean Black Fin
Compressor	Motor Output x Number	W x No.	(5,300 x 3) + (4,200 x 1)	(5,300 x 3) + (4,200 x 1)	(5,300 x 3) + (4,200 x 1)	5,300 x 4	5,300 x 4
	Type		Propeller fan	Propeller fan	Propeller fan	Propeller fan	Propeller fan
Fan	Air Flow Rate (High)	m ³ /min	320 x 2	320 x 2	320 x 2	320 x 2	(320 x 2) + (240 x 1)
	Drive		DC INVERTER	DC INVERTER	DC INVERTER	DC INVERTER	DC INVERTER
Liquid Pipe		mm(inch)	19.05(3/4)	19.05(3/4)	19.05(3/4)	19.05(3/4)	19.05(3/4)
Low Pressure Gas Pipe		mm(inch)	41.3(1-5/8)	41.3(1-5/8)	41.3(1-5/8)	41.3(1-5/8)	41.3(1-5/8)
High Pressure Gas Pipe		mm(inch)	34.9(1-3/8)	34.9(1-3/8)	34.9(1-3/8)	34.9(1-3/8)	34.9(1-3/8)
Dimensions (W x H x D)		mm	(1,240 x 1,690 x 760) x 2	(1,240 x 1,690 x 760) x 2	(1,240 x 1,690 x 760) x 2	(1,240 x 1,690 x 760) x 2	(1,240 x 1,690 x 760) x 2 + (930 x 1,690 x 760) x 1
Net Weight		kg	(310 x 1) + (300 x 1)	(310 x 1) + (300 x 1)	(310 x 1) + (300 x 1)	310 x 2	(310 x 1) + (237 x 1) + (215 x 1)
Sound Pressure Level	Cooling	dB(A)	66.5	66.8	67.8	68.0	67.0
	Heating	dB(A)	68.2	68.9	69.3	70.0	68.6
Sound Power Level	Cooling	dB(A)	96.8	97.1	97.1	98.0	96.4
	Heating	dB(A)	100.5	100.8	101.1	102.0	100.3
Communication Cable		No. x mm ² (VCTF-SB)	2C x 1.0 - 1.5	2C x 1.0 - 1.5	2C x 1.0 - 1.5	2C x 1.0 - 1.5	2C x 1.0 - 1.5
Refrigerant	Refrigerant Name		R410A	R410A	R410A	R410A	R410A
	Precharged Amount in factory	kg	33.0	33.0	33.0	34.0	40.0
		lbs	72.8	72.8	72.8	75.0	88.2
	GWP		2087.5	2087.5	2087.5	2087.5	2087.5
	t-CO ₂ eq		68.9	68.9	68.9	71.0	83.5
Control		Electronic Expansion Valve	Electronic Expansion Valve	Electronic Expansion Valve	Electronic Expansion Valve	Electronic Expansion Valve	
Refrigerant Oil	Type		FVC68D(PVE)	FVC68D(PVE)	FVC68D(PVE)	FVC68D(PVE)	FVC68D(PVE)
	Charge	cc	10,400	10,400	10,400	10,400	13,000
Power Supply	∅, V, Hz		380-415, 3, 50	380-415, 3, 50	380-415, 3, 50	380-415, 3, 50	380-415, 3, 50
			380, 3, 60	380, 3, 60	380, 3, 60	380, 3, 60	380, 3, 60
Number of Maximum Connectable Indoor Units			64	64	64	64	64

* This product contains Fluorinated Greenhouse Gases. (R410A)

Non TROPICAL MODEL

HIGH EFFICIENCY

ARUM520LTE5 / ARUM540LTE5 / ARUM560LTE5
ARUM580LTE5 / ARUM600LTE5



HP			52	54	56	58	60
Model Name	Combination Unit		ARUM520LTE5	ARUM540LTE5	ARUM560LTE5	ARUM580LTE5	ARUM600LTE5
	Independent Unit		ARUM240LTE5 ARUM160LTE5 ARUM120LTE5	ARUM240LTE5 ARUM180LTE5 ARUM120LTE5	ARUM240LTE5 ARUM200LTE5 ARUM120LTE5	ARUM240LTE5 ARUM220LTE5 ARUM120LTE5	ARUM240LTE5 ARUM240LTE5 ARUM120LTE5
Capacity	Cooling (Rated)	kW	145.6	151.2	156.8	162.4	168.0
	Heating (Rated)	kW	145.6	151.2	156.8	162.4	168.0
	Heating (Max)	kW Btu/h	162.5 554,300	168.8 575,800	175.1 597,300	181.4 618,800	186.3 635,700
Input	Cooling (Rated)	kW	35.9	35.9	37.8	40.7	42.4
	Heating (Rated)	kW	33.0	32.9	34.9	36.9	38.6
	Heating (Max)	kW	39.4	39.0	41.7	43.8	45.9
EER			4.06	4.21	4.15	3.99	3.96
ESEER			6.76	7.02	6.91	6.78	6.73
ESEER (SLC)			8.08	8.17	8.01	8.08	8.15
COP	COP (Rated)		4.41	4.60	4.49	4.40	4.35
	COP (Max)		4.12	4.33	4.19	4.14	4.06
Casing Color			Warm Gray / Dawn Gray	Warm Gray / Dawn Gray	Warm Gray / Dawn Gray	Warm Gray / Dawn Gray	Warm Gray / Dawn Gray
Heat Exchanger			Ocean Black Fin	Ocean Black Fin	Ocean Black Fin	Ocean Black Fin	Ocean Black Fin
Compressor	Motor Output x Number	W x No.	5,300 x 4	(5,300 x 4) + (4,200 x 1)	(5,300 x 4) + (4,200 x 1)	(5,300 x 4) + (4,200 x 1)	5,300 x 5
	Type		Propeller fan	Propeller fan	Propeller fan	Propeller fan	Propeller fan
Fan	Air Flow Rate (High)	m ³ /min	(320 x 2) + (240 x 1)	(320 x 2) + (240 x 1)	(320 x 2) + (240 x 1)	(320 x 2) + (240 x 1)	(320 x 2) + (240 x 1)
	Drive		DC INVERTER	DC INVERTER	DC INVERTER	DC INVERTER	DC INVERTER
Liquid Pipe		mm(inch)	19.05(3/4)	19.05(3/4)	19.05(3/4)	19.05(3/4)	19.05(3/4)
Low Pressure Gas Pipe		mm(inch)	41.3(1-5/8)	41.3(1-5/8)	41.3(1-5/8)	41.3(1-5/8)	41.3(1-5/8)
High Pressure Gas Pipe		mm(inch)	34.9(1-3/8)	34.9(1-3/8)	34.9(1-3/8)	34.9(1-3/8)	34.9(1-3/8)
Dimensions (W x H x D)		mm	(1,240 x 1,690 x 760) x 2 + (930 x 1,690 x 760) x 1	(1,240 x 1,690 x 760) x 2 + (930 x 1,690 x 760) x 1	(1,240 x 1,690 x 760) x 2 + (930 x 1,690 x 760) x 1	(1,240 x 1,690 x 760) x 2 + (930 x 1,690 x 760) x 1	(1,240 x 1,690 x 760) x 2 + (930 x 1,690 x 760) x 1
Net Weight		kg	(310 x 1) + (237 x 1) + (215 x 1)	(310 x 1) + (300 x 1) + (215 x 1)	(310 x 1) + (300 x 1) + (215 x 1)	(310 x 1) + (300 x 1) + (215 x 1)	(310 x 2) + (215 x 1)
Sound Pressure Level	Cooling	dB(A)	67.1	67.2	67.4	68.3	68.5
	Heating	dB(A)	68.7	68.8	69.5	69.8	70.4
Sound Power Level	Cooling	dB(A)	96.6	97.1	97.4	97.4	98.3
	Heating	dB(A)	100.5	100.8	101.0	101.4	102.2
Communication Cable		No. x mm ² (VCTF-SB)	2C x 1.0 - 1.5	2C x 1.0 - 1.5	2C x 1.0 - 1.5	2C x 1.0 - 1.5	2C x 1.0 - 1.5
Refrigerant	Refrigerant Name		R410A	R410A	R410A	R410A	R410A
	Precharged Amount in factory	kg	40.0	42.5	42.5	42.5	43.5
		lbs	88.2	93.7	93.7	93.7	95.9
	GWP		2087.5	2087.5	2087.5	2087.5	2087.5
	t-CO ₂ eq		83.5	88.7	88.7	88.7	90.8
Control		Electronic Expansion Valve	Electronic Expansion Valve	Electronic Expansion Valve	Electronic Expansion Valve	Electronic Expansion Valve	
Refrigerant Oil	Type		FVC68D(PVE)	FVC68D(PVE)	FVC68D(PVE)	FVC68D(PVE)	FVC68D(PVE)
	Charge	cc	13,000	14,300	14,300	14,300	14,300
Power Supply	∅, V, Hz		380-415, 3, 50	380-415, 3, 50	380-415, 3, 50	380-415, 3, 50	380-415, 3, 50
			380, 3, 60	380, 3, 60	380, 3, 60	380, 3, 60	380, 3, 60
Number of Maximum Connectable Indoor Units			64	64	64	64	64

* This product contains Fluorinated Greenhouse Gases. (R410A)

MULTI V 5

Non TROPICAL MODEL

HIGH EFFICIENCY

ARUM620LTE5 / ARUM640LTE5 / ARUM660LTE5
ARUM680LTE5 / ARUM700LTE5 / ARUM720LTE5



HP			62	64	66	68	70	72
Model Name	Combination Unit		ARUM620LTE5	ARUM640LTE5	ARUM660LTE5	ARUM680LTE5	ARUM700LTE5	ARUM720LTE5
	Independent Unit		ARUM240LTE5 ARUM240LTE5 ARUM140LTE5	ARUM240LTE5 ARUM240LTE5 ARUM160LTE5	ARUM240LTE5 ARUM240LTE5 ARUM180LTE5	ARUM240LTE5 ARUM240LTE5 ARUM200LTE5	ARUM240LTE5 ARUM240LTE5 ARUM220LTE5	ARUM240LTE5 ARUM240LTE5 ARUM240LTE5
Capacity	Cooling (Rated)	kW	173.6	179.2	184.8	190.4	196.0	201.6
	Heating (Rated)	kW	173.6	179.2	184.8	190.4	196.0	201.6
	Heating (Max)	kW	192.6	198.9	205.2	211.5	217.8	222.8
Input	Cooling (Rated)	kW	43.5	45.7	45.7	47.6	50.5	52.2
	Heating (Rated)	kW	39.9	42.1	41.9	44.0	45.9	47.7
	Heating (Max)	kW	47.3	50.0	49.5	52.3	54.4	56.4
EER			3.99	3.92	4.04	4.00	3.88	3.86
ESEER			6.73	6.58	6.78	6.70	6.60	6.57
ESEER (SLC)			8.09	7.98	8.05	7.92	7.99	8.05
COP	COP (Rated)		4.35	4.26	4.41	4.33	4.27	4.23
	COP (Max)		4.07	3.98	4.14	4.05	4.01	3.95
Casing Color			Warm Gray / Dawn Gray	Warm Gray / Dawn Gray	Warm Gray / Dawn Gray	Warm Gray / Dawn Gray	Warm Gray / Dawn Gray	Warm Gray / Dawn Gray
Heat Exchanger			Ocean Black Fin	Ocean Black Fin	Ocean Black Fin	Ocean Black Fin	Ocean Black Fin	Ocean Black Fin
Compressor	Motor Output x Number	W x No.	5,300 x 5	5,300 x 5	(5,300 x 5) + (4,200 x 1)	(5,300 x 5) + (4,200 x 1)	(5,300 x 5) + (4,200 x 1)	5,300 x 6
	Type		Propeller fan	Propeller fan	Propeller fan	Propeller fan	Propeller fan	Propeller fan
Fan	Air Flow Rate (High)	m ³ /min	320 x 3	320 x 3	320 x 3	320 x 3	320 x 3	320 x 3
	Drive		DC INVERTER	DC INVERTER	DC INVERTER	DC INVERTER	DC INVERTER	DC INVERTER
Liquid Pipe		mm(inch)	22.2(7/8)	22.2(7/8)	22.2(7/8)	22.2(7/8)	22.2(7/8)	22.2(7/8)
Low Pressure Gas Pipe		mm(inch)	44.5(1-3/4)	44.5(1-3/4)	53.98(2-1/8)	53.98(2-1/8)	53.98(2-1/8)	53.98(2-1/8)
High Pressure Gas Pipe		mm(inch)	41.3(1-5/8)	41.3(1-5/8)	44.5(1-3/4)	44.5(1-3/4)	44.5(1-3/4)	44.5(1-3/4)
Dimensions (W x H x D)		mm	(1,240 x 1,690 x 760) x 3	(1,240 x 1,690 x 760) x 3	(1,240 x 1,690 x 760) x 3	(1,240 x 1,690 x 760) x 3	(1,240 x 1,690 x 760) x 3	(1,240 x 1,690 x 760) x 3
Net Weight		kg	(310 x 2) + (237 x 1)	(310 x 2) + (237 x 1)	(310 x 2) + (300 x 1)	(310 x 2) + (300 x 1)	(310 x 2) + (300 x 1)	310 x 3
Sound Pressure Level	Cooling	dB(A)	68.6	68.7	68.8	69.0	69.6	69.8
	Heating	dB(A)	70.5	70.6	70.6	71.1	71.3	71.8
Sound Power Level	Cooling	dB(A)	98.5	98.6	99.0	99.2	99.2	99.8
	Heating	dB(A)	102.5	102.6	102.8	103.0	103.0	103.8
Communication Cable		No. x mm ² (VCTF-SB)	2C x 1.0 - 1.5	2C x 1.0 - 1.5	2C x 1.0 - 1.5	2C x 1.0 - 1.5	2C x 1.0 - 1.5	2C x 1.0 - 1.5
Refrigerant	Refrigerant Name		R410A	R410A	R410A	R410A	R410A	R410A
	Precharged Amount in factory	kg	47.5	47.5	50.0	50.0	50.0	51.0
		lbs	104.7	104.7	110.2	110.2	110.2	112.4
	GWP		2087.5	2087.5	2087.5	2087.5	2087.5	2087.5
	t-CO ₂ eq		99.2	99.2	104.4	104.4	104.4	106.5
Refrigerant Control			Electronic Expansion Valve	Electronic Expansion Valve	Electronic Expansion Valve	Electronic Expansion Valve	Electronic Expansion Valve	Electronic Expansion Valve
Refrigerant Oil	Type		FVC68D(PVE)	FVC68D(PVE)	FVC68D(PVE)	FVC68D(PVE)	FVC68D(PVE)	FVC68D(PVE)
	Charge	cc	14,300	14,300	15,600	15,600	15,600	15,600
Power Supply		∅, V, Hz	380-415, 3, 50	380-415, 3, 50	380-415, 3, 50	380-415, 3, 50	380-415, 3, 50	380-415, 3, 50
			380, 3, 60	380, 3, 60	380, 3, 60	380, 3, 60	380, 3, 60	380, 3, 60
Number of Maximum Connectable Indoor Units			64	64	64	64	64	64

* This product contains Fluorinated Greenhouse Gases. (R410A)

Non TROPICAL MODEL

HIGH EFFICIENCY

ARUM740LTE5 / ARUM760LTE5 / ARUM780LTE5
ARUM800LTE5 / ARUM820LTE5 / ARUM840LTE5



HP			74	76	78	80	82	84
Model Name	Combination Unit		ARUM740LTE5	ARUM760LTE5	ARUM780LTE5	ARUM800LTE5	ARUM820LTE5	ARUM840LTE5
	Independent Unit		ARUM240LTE5 ARUM240LTE5 ARUM140LTE5 ARUM120LTE5	ARUM240LTE5 ARUM240LTE5 ARUM160LTE5 ARUM120LTE5	ARUM240LTE5 ARUM240LTE5 ARUM180LTE5 ARUM120LTE5	ARUM240LTE5 ARUM240LTE5 ARUM200LTE5 ARUM120LTE5	ARUM240LTE5 ARUM240LTE5 ARUM220LTE5 ARUM120LTE5	ARUM240LTE5 ARUM240LTE5 ARUM240LTE5 ARUM120LTE5
Capacity	Cooling (Rated)	kW	207.2	212.8	218.4	224.0	229.6	235.2
	Heating (Rated)	kW	207.2	212.8	218.4	224.0	229.6	235.2
	Heating (Max)	kW	230.4	236.7	243.0	249.3	255.6	260.6
Input	Cooling (Rated)	kW	51.1	53.3	53.3	55.2	58.1	59.8
	Heating (Rated)	kW	46.8	48.9	48.8	50.8	52.8	54.5
	Heating (Max)	kW	55.6	58.2	57.8	60.5	62.6	64.7
EER			4.06	3.99	4.10	4.06	3.95	3.93
ESEER			6.84	6.70	6.88	6.80	6.72	6.69
ESEER (SLC)			8.17	8.07	8.13	8.02	8.07	8.12
COP	COP (Rated)		4.43	4.35	4.48	4.41	4.35	4.31
	COP (Max)		4.15	4.06	4.20	4.12	4.08	4.03
Casing Color			Warm Gray / Dawn Gray	Warm Gray / Dawn Gray	Warm Gray / Dawn Gray	Warm Gray / Dawn Gray	Warm Gray / Dawn Gray	Warm Gray / Dawn Gray
Heat Exchanger			Ocean Black Fin	Ocean Black Fin	Ocean Black Fin	Ocean Black Fin	Ocean Black Fin	Ocean Black Fin
Compressor	Motor Output x Number	W x No.	5,300 x 6	5,300 x 6	(5,300 x 6) + (4,200 x 1)	(5,300 x 6) + (4,200 x 1)	(5,300 x 6) + (4,200 x 1)	5,300 x 7
	Type		Propeller fan	Propeller fan	Propeller fan	Propeller fan	Propeller fan	Propeller fan
Fan	Air Flow Rate (High)	m ³ /min	(320 x 3) + (240 x 1)	(320 x 3) + (240 x 1)	(320 x 3) + (240 x 1)	(320 x 3) + (240 x 1)	(320 x 3) + (240 x 1)	(320 x 3) + (240 x 1)
	Drive		DC INVERTER	DC INVERTER	DC INVERTER	DC INVERTER	DC INVERTER	DC INVERTER
Liquid Pipe		mm(inch)	22.2(7/8)	22.2(7/8)	22.2(7/8)	22.2(7/8)	22.2(7/8)	22.2(7/8)
Low Pressure Gas Pipe		mm(inch)	53.98(2-1/8)	53.98(2-1/8)	53.98(2-1/8)	53.98(2-1/8)	53.98(2-1/8)	53.98(2-1/8)
High Pressure Gas Pipe		mm(inch)	44.5(1-3/4)	44.5(1-3/4)	44.5(1-3/4)	44.5(1-3/4)	44.5(1-3/4)	44.5(1-3/4)
Dimensions (W x H x D)		mm	(1,240 x 1,690 x 760) x 3 + (930 x 1,690 x 760) x 1	(1,240 x 1,690 x 760) x 3 + (930 x 1,690 x 760) x 1	(1,240 x 1,690 x 760) x 3 + (930 x 1,690 x 760) x 1	(1,240 x 1,690 x 760) x 3 + (930 x 1,690 x 760) x 1	(1,240 x 1,690 x 760) x 3 + (930 x 1,690 x 760) x 1	(1,240 x 1,690 x 760) x 3 + (930 x 1,690 x 760) x 1
Net Weight		kg	(310 x 2) + (237 x 1) + (215 x 1)	(310 x 2) + (237 x 1) + (215 x 1)	(310 x 2) + (300 x 1) + (215 x 1)	(310 x 2) + (300 x 1) + (215 x 1)	(310 x 2) + (300 x 1) + (215 x 1)	(310 x 3) + (215 x 1)
Sound Pressure Level	Cooling	dB(A)	69.1	69.2	69.2	69.4	70.0	70.1
	Heating	dB(A)	70.9	70.9	71.0	71.4	71.6	72.1
Sound Power Level	Cooling	dB(A)	98.8	98.9	99.2	99.4	99.4	99.9
	Heating	dB(A)	102.7	102.8	103.0	103.2	103.4	103.9
Communication Cable		No. x mm ² (VCTF-SB)	2C x 1.0 - 1.5	2C x 1.0 - 1.5	2C x 1.0 - 1.5	2C x 1.0 - 1.5	2C x 1.0 - 1.5	2C x 1.0 - 1.5
Refrigerant	Refrigerant Name		R410A	R410A	R410A	R410A	R410A	R410A
	Precharged Amount in factory	kg	57.0	57.0	59.5	59.5	59.5	60.5
		lbs	125.7	125.7	131.2	131.2	131.2	133.4
	GWP		2087.5	2087.5	2087.5	2087.5	2087.5	2087.5
	t-CO ₂ eq		119.0	119.0	124.2	124.2	124.2	126.3
Refrigerant Control			Electronic Expansion Valve	Electronic Expansion Valve	Electronic Expansion Valve	Electronic Expansion Valve	Electronic Expansion Valve	Electronic Expansion Valve
Refrigerant Oil	Type		FVC68D(PVE)	FVC68D(PVE)	FVC68D(PVE)	FVC68D(PVE)	FVC68D(PVE)	FVC68D(PVE)
	Charge	cc	18,200	18,200	19,500	19,500	19,500	19,500
Power Supply		∅, V, Hz	380-415, 3, 50	380-415, 3, 50	380-415, 3, 50	380-415, 3, 50	380-415, 3, 50	380-415, 3, 50
			380, 3, 60	380, 3, 60	380, 3, 60	380, 3, 60	380, 3, 60	380, 3, 60
Number of Maximum Connectable Indoor Units			64	64	64	64	64	64

* This product contains Fluorinated Greenhouse Gases. (R410A)

OUTDOOR UNITS

INDOOR UNITS

HOT WATER SOLUTION

VENTILATION SOLUTIONS

CONTROL SOLUTIONS

ACCESSORIES

MULTI V 5

Non TROPICAL MODEL

HIGH EFFICIENCY

ARUM860LTE5 / ARUM880LTE5 / ARUM900LTE5
ARUM920LTE5 / ARUM940LTE5 / ARUM960LTE5



HP		86	88	90	92	94	96	
Model Name	Combination Unit	ARUM860LTE5	ARUM880LTE5	ARUM900LTE5	ARUM920LTE5	ARUM940LTE5	ARUM960LTE5	
	Independent Unit	ARUM240LTE5 ARUM240LTE5 ARUM240LTE5 ARUM140LTE5	ARUM240LTE5 ARUM240LTE5 ARUM240LTE5 ARUM160LTE5	ARUM240LTE5 ARUM240LTE5 ARUM240LTE5 ARUM180LTE5	ARUM240LTE5 ARUM240LTE5 ARUM240LTE5 ARUM200LTE5	ARUM240LTE5 ARUM240LTE5 ARUM240LTE5 ARUM220LTE5	ARUM240LTE5 ARUM240LTE5 ARUM240LTE5 ARUM240LTE5	
Capacity	Cooling (Rated)	kW	240.8	246.4	252.0	257.6	263.2	268.8
	Heating (Rated)	kW	240.8	246.4	252.0	257.6	263.2	268.8
	Heating (Max)	kW	266.9	273.2	279.5	285.8	292.1	297.0
		Btu/h	910,600	932,000	953,500	975,000	996,500	1,013,400
Input	Cooling (Rated)	kW	60.9	63.1	63.1	65.0	67.9	69.6
	Heating (Rated)	kW	55.8	58.0	57.8	59.9	61.8	63.6
	Heating (Max)	kW	66.1	68.8	68.3	71.1	73.2	75.2
EER		3.96	3.91	3.99	3.96	3.88	3.86	
ESEER		6.68	6.57	6.72	6.66	6.60	6.57	
ESEER (SLC)		8.07	8.00	8.04	7.95	8.00	8.05	
COP	COP (Rated)	4.32	4.25	4.36	4.30	4.26	4.23	
	COP (Max)	4.04	3.97	4.09	4.02	3.99	3.95	
Casing Color		Warm Gray / Dawn Gray	Warm Gray / Dawn Gray	Warm Gray / Dawn Gray	Warm Gray / Dawn Gray	Warm Gray / Dawn Gray	Warm Gray / Dawn Gray	
Heat Exchanger		Ocean Black Fin	Ocean Black Fin	Ocean Black Fin	Ocean Black Fin	Ocean Black Fin	Ocean Black Fin	
Compressor	Motor Output x Number	W x No.	5,300 x 7	5,300 x 7	(5,300 x 7) + (4,200 x 1)	(5,300 x 7) + (4,200 x 1)	(5,300 x 7) + (4,200 x 1)	5,300 x 8
	Type		Propeller fan	Propeller fan	Propeller fan	Propeller fan	Propeller fan	Propeller fan
Fan	Air Flow Rate (High)	m ³ /min	320 x 4	320 x 4	320 x 4	320 x 4	320 x 4	320 x 4
	Drive		DC INVERTER	DC INVERTER	DC INVERTER	DC INVERTER	DC INVERTER	DC INVERTER
Liquid Pipe	mm(inch)	22.2(7/8)	22.2(7/8)	22.2(7/8)	22.2(7/8)	22.2(7/8)	22.2(7/8)	
Low Pressure Gas Pipe	mm(inch)	53.98(2-1/8)	53.98(2-1/8)	53.98(2-1/8)	53.98(2-1/8)	53.98(2-1/8)	53.98(2-1/8)	
High Pressure Gas Pipe	mm(inch)	44.5(1-3/4)	44.5(1-3/4)	44.5(1-3/4)	44.5(1-3/4)	44.5(1-3/4)	44.5(1-3/4)	
Dimensions (W x H x D)	mm	(1,240 x 1,690 x 760) x 4	(1,240 x 1,690 x 760) x 4	(1,240 x 1,690 x 760) x 4	(1,240 x 1,690 x 760) x 4	(1,240 x 1,690 x 760) x 4	(1,240 x 1,690 x 760) x 4	
Net Weight	kg	(310 x 3) + (237 x 1)	(310 x 3) + (237 x 1)	(310 x 3) + (300 x 1)	(310 x 3) + (300 x 1)	(310 x 3) + (300 x 1)	310 x 4	
Sound Pressure Level	Cooling	dB(A)	70.2	70.3	70.3	70.4	70.9	71.0
	Heating	dB(A)	72.1	72.2	72.2	72.5	72.7	73.0
Sound Power Level	Cooling	dB(A)	101.1	100.2	100.4	100.6	100.6	101.0
	Heating	dB(A)	104.1	104.2	104.3	104.4	104.6	105.0
Communication Cable	No. x mm ² (VCTF-SB)	2C x 1.0 - 1.5	2C x 1.0 - 1.5	2C x 1.0 - 1.5	2C x 1.0 - 1.5	2C x 1.0 - 1.5	2C x 1.0 - 1.5	
Refrigerant	Refrigerant Name		R410A	R410A	R410A	R410A	R410A	R410A
	Precharged Amount in factory	kg	64.5	64.5	67.0	67.0	67.0	68.0
		lbs	142.2	142.2	147.7	147.7	147.7	149.9
	GWP		2087.5	2087.5	2087.5	2087.5	2087.5	2087.5
	t-CO ₂ eq		134.6	134.6	139.9	139.9	139.9	142.0
Refrigerant Oil	Control		Electronic Expansion Valve	Electronic Expansion Valve	Electronic Expansion Valve	Electronic Expansion Valve	Electronic Expansion Valve	Electronic Expansion Valve
	Type		FVC68D(PVE)	FVC68D(PVE)	FVC68D(PVE)	FVC68D(PVE)	FVC68D(PVE)	FVC68D(PVE)
Power Supply	Charge	cc	19,500	19,500	20,800	20,800	20,800	20,800
	Ø, V, Hz		380-415, 3, 50	380-415, 3, 50	380-415, 3, 50	380-415, 3, 50	380-415, 3, 50	380-415, 3, 50
Number of Maximum Connectable Indoor Units		64	64	64	64	64	64	

NOTE

- Eurovent Test Condition : For more info regarding program consult www.eurovent-certification.com
- Capacities are based on the following conditions :
 - Cooling Temperature : Indoor 27°C(80.6°F) DB / 19°C(66.2°F) WB, Outdoor 35°C(95°F) DB / 24°C(75.2°F) WB
 - Heating Temperature : Indoor 20°C(68°F) DB / 15°C(59°F) WB, Outdoor 7°C(44.6°F) DB / 6°C(42.8°F) WB
 - Piping Length : Interconnected Pipe Length = 7.5m
 - Difference Limit of Elevation (Outdoor ~ Indoor Unit) is Zero.
- Wiring cable size must comply with the applicable local and national code.
- Sound Level Values can be increased owing to ambient conditions during operation.
- The numbers in parentheses means maximum connectable indoor units in accordance with outdoor units combination. The recommended ratio is 130%.

Part Load Ratio	Outdoor Air Temp. (°C (°F)DB)	Weighting Coefficients
100%	35 (95)	0.03
75%	30 (86)	0.33
50%	25 (77)	0.41
25%	20 (68)	0.23

 - Formula : 0.03 x EER100% + 0.33 x EER75% + 0.41 x EER50% + 0.23 x EER25%
- Due to our policy of innovation some specifications may be changed without notification.
- Power factor could vary less than 1% according to the operating conditions.
- This product contains Fluorinated greenhouse gases.

* This product contains Fluorinated Greenhouse Gases. (R410A)

MULTI V 5

Non TROPICAL MODEL

STANDARD

ARUN080LTE5 / ARUN100LTE5 / ARUN120LTE5 / ARUN140LTE5

LG participates in the ECP programme for EUROVENT VRF program. Check ongoing validity of certification : www.eurovent-certification.com



HP			8	10	12	14
Model Name	Combination Unit		ARUN080LTE5	ARUN100LTE5	ARUN120LTE5	ARUN140LTE5
	Independent Unit		ARUN080LTE5	ARUN100LTE5	ARUN120LTE5	ARUN140LTE5
Capacity	Cooling (Rated)	kW	22.4	28.0	33.6	39.2
		Btu/h	76,400	95,500	114,600	133,800
	Heating (Rated)	kW	25.2	31.5	37.8	44.1
		Btu/h	86,000	107,500	129,000	150,500
Input	Cooling (Rated)	kW	4.59	5.70	7.91	9.12
	Heating (Rated)	kW	4.74	5.78	8.06	9.78
Input ¹⁾	Cooling (Rated)	kW	4.99	6.45	8.42	10.21
	Heating (Rated)	kW	4.27	5.29	7.37	9.03
	Heating (Max)	kW	5.14	6.37	8.89	10.80
EER (Rated)			4.88	4.91	4.25	4.30
COP (Rated)			5.32	5.45	4.69	4.51
EER ¹⁾			4.49	4.34	3.99	3.84
ESEER			7.57	7.31	6.72	6.23
ESEER (SLC)			8.51	8.23	7.74	7.03
Power Factor	Rated	-	0.93	0.93	0.93	0.93
Exterior	Color		Warm Gray / Dawn Gray	Warm Gray / Dawn Gray	Warm Gray / Dawn Gray	Warm Gray / Dawn Gray
	RAL code		NL503K / NA507K	NL503K / NA507K	NL503K / NA507K	NL503K / NA507K
Heat Exchanger			Wide Louver Plus	Wide Louver Plus	Wide Louver Plus	Wide Louver Plus
Compressor	Motor Output x Number	W x No.	5,300 x 1	5,300 x 1	5,300 x 1	5,300 x 1
	Type		Propeller fan	Propeller fan	Propeller fan	Propeller fan
Fan	Motor Output x Number	W	1,200 x 1	1,200 x 1	1,200 x 1	900 x 2
	Air Flow Rate (High)	m ³ /min	240 x 1	240 x 1	240 x 1	320 x 1
		ft ³ /min	8,476 x 1	8,476 x 1	8,476 x 1	11,301 x 1
	External Static Pressure (Max, Pa)		80	80	80	80
	Drive		DC INVERTER	DC INVERTER	DC INVERTER	DC INVERTER
Pipe Connctions	Liquid Pipe	mm(inch)	9.52(3/8)	9.52(3/8)	12.7(1/2)	12.7(1/2)
	Gas Pipe	mm(inch)	19.05(3/4)	22.2(7/8)	28.58(1-1/8)	28.58(1-1/8)
Dimensions (W x H x D)	mm	(930 x 1,690 x 760) x 1	(930 x 1,690 x 760) x 1	(930 x 1,690 x 760) x 1	(1,240 x 1,690 x 760) x 1	
Net Weight		kg	199 x 1	199 x 1	199 x 1	221 x 1
		lbs	439 x 1	439 x 1	439 x 1	487 x 1
Sound Pressure Level	Cooling	dB(A)	58.0	58.0	59.0	60.0
	Heating	dB(A)	59.0	59.0	60.0	61.0
Sound Power Level	Cooling	dB(A)	78.0	78.0	79.0	82.0
	Heating	dB(A)	79.0	79.0	80.0	84.0
Communication Cable		No.xmm ² (VCTF-SB)	2C x 1.0 - 1.5	2C x 1.0 - 1.5	2C x 1.0 - 1.5	2C x 1.0 - 1.5
Refrigerant	Refrigerant Name		R410A	R410A	R410A	R410A
	Precharged Amount in factory	kg	10.0	10.0	10.0	13.0
		lbs	22.0	22.0	22.0	28.7
	TCO ₂ eq		20.9	20.9	20.9	27.1
	Control		Electronic Expansion Valve	Electronic Expansion Valve	Electronic Expansion Valve	Electronic Expansion Valve
Power Supply		∅, V, Hz	380-415, 3, 50	380-415, 3, 50	380-415, 3, 50	380-415, 3, 50
			380, 3, 60	380, 3, 60	380, 3, 60	380, 3, 60
Number of Maxmum Connectable Indoor Units			13(20)	16(25)	20(30)	23(35)

Note : 1. Due to our policy of innovation some specifications may be changed without notification.
 2. Wiring cable size must comply with the applicable local and national codes. And "Electric characteristics" chapter should be considered for electrical work and design. Especially the power cable and circuit breaker should be selected in accordance with that.
 3. Power factor could vary less than ±1% according to the operating conditions.
 4. Sound pressure level is measured on the rated condition in the anechoic rooms by ISO 3745 standard. Sound power level is measured on the rated condition in the reverberation rooms by ISO 3741 standard. Therefore, these values can be increased owing to ambient conditions during operation.
 5. Performances are based on the following conditions : Cooling : Indoor Ambient Temp. 27°CDB / 19°CWB, Outdoor Ambient Temp. 35°CDB / 24°CWB
 Heating : Indoor Ambient Temp. 20°CDB / 15°CWB, Outdoor Ambient Temp. 7°CDB / 6°CWB
 Interconnected Pipe Length is 7.5m and difference of Elevation (Outdoor - Indoor Unit) is Zero.
 6. The numbers in parentheses means maximum connectable indoor units in accordance with outdoor units combination. The recommended ratio is 130%.
 7. This product contains Fluorinated greenhouse gases.(R410A, GWP(Global warming potential) = 2087.5)
 * Eurovent test Condition

Non TROPICAL MODEL

STANDARD

ARUN160LTE5 / ARUN180LTE5 / ARUN200LTE5 / ARUN220LTE5

LG participates in the ECP programme for EUROVENT VRF program. Check ongoing validity of certification : www.eurovent-certification.com



HP			16	18	20	22
Model Name	Combination Unit		ARUN160LTE5	ARUN180LTE5	ARUN200LTE5	ARUN220LTE5
	Independent Unit		ARUN160LTE5	ARUN180LTE5	ARUN200LTE5	ARUN220LTE5
Capacity	Cooling (Rated)	kW	44.8	50.4	56.0	61.6
		Btu/h	152,900	172,000	191,100	210,200
	Heating (Rated)	kW	50.4	56.7	63.0	69.3
		Btu/h	172,000	193,500	215,000	236,500
Input	Cooling (Rated)	kW	10.80	10.96	12.31	14.84
	Heating (Rated)	kW	11.59	12.06	15.52	17.54
Input ¹⁾	Cooling (Rated)	kW	12.80	12.82	15.01	18.44
	Heating (Rated)	kW	11.43	11.25	13.56	15.71
	Heating (Max)	kW	13.77	13.27	16.32	18.62
EER (Rated)			4.15	4.60	4.55	4.15
COP (Rated)			4.35	4.70	4.06	3.95
EER ¹⁾			3.50	3.93	3.73	3.34
ESEER			5.61	6.30	5.98	5.68
ESEER (SLC)			6.63	6.90	6.55	6.70
Power Factor	Rated	-	0.93	0.93	0.93	0.93
Exterior	Color		Warm Gray / Dawn Gray	Warm Gray / Dawn Gray	Warm Gray / Dawn Gray	Warm Gray / Dawn Gray
	RAL code		NL503K / NA507K	NL503K / NA507K	NL503K / NA507K	NL503K / NA507K
Heat Exchanger			Wide Louver Plus	Wide Louver Plus	Wide Louver Plus	Wide Louver Plus
Compressor	Motor Output x Number	W x No.	5,300 x 1	5,300 x 1 + 4,200 x 1	5,300 x 2	5,300 x 2
	Type		Propeller fan	Propeller fan	Propeller fan	Propeller fan
Fan	Motor Output x Number	W	900 x 2	900 x 2	900 x 2	900 x 2
	Air Flow Rate (High)	m ³ /min	320 x 1	320 x 1	320 x 1	320 x 1
		ft ³ /min	11,301 x 1	11,301 x 1	11,301 x 1	11,301 x 1
	External Static Pressure (Max, Pa)		80	80	80	80
	Drive		DC INVERTER	DC INVERTER	DC INVERTER	DC INVERTER
Pipe Connctions	Liquid Pipe	mm(inch)	12.7(1/2)	15.88(5/8)	15.88(5/8)	15.88(5/8)
	Gas Pipe	mm(inch)	28.58(1-1/8)	28.58(1-1/8)	28.58(1-1/8)	28.58(1-1/8)
Dimensions (W x H x D)	mm	(1,240 x 1,690 x 760) x 1	(1,240 x 1,690 x 760) x 1	(1,240 x 1,690 x 760) x 1	(1,240 x 1,690 x 760) x 1	
Net Weight		kg	221 x 1	261 x 1	281 x 1	281 x 1
		lbs	487 x 1	575 x 1	619 x 1	619 x 1
Sound Pressure Level	Cooling	dB(A)	60.5	61.0	62.0	64.5
	Heating	dB(A)	61.5	62.0	64.5	65.5
Sound Power Level	Cooling	dB(A)	83.0	85.0	86.0	86.0
	Heating	dB(A)	85.0	86.0	87.0	88.0
Communication Cable		No.xmm ² (VCTF-SB)	2C x 1.0 - 1.5	2C x 1.0 - 1.5	2C x 1.0 - 1.5	2C x 1.0 - 1.5
Refrigerant	Refrigerant Name		R410A	R410A	R410A	R410A
	Precharged Amount in factory	kg	13.0	13.0	14.0	14.0
		lbs	28.7	28.7	30.9	30.9
	TCO ₂ eq		27.1	27.1	29.2	29.2
	Control		Electronic Expansion Valve	Electronic Expansion Valve	Electronic Expansion Valve	Electronic Expansion Valve
Power Supply		∅, V, Hz	380-415, 3, 50	380-415, 3, 50	380-415, 3, 50	380-415, 3, 50
			380, 3, 60	380, 3, 60	380, 3, 60	380, 3, 60
Number of Maxmum Connectable Indoor Units			26(40)	29(45)	32(50)	35(56)

Note : 1. Due to our policy of innovation some specifications may be changed without notification.
 2. Wiring cable size must comply with the applicable local and national codes. And "Electric characteristics" chapter should be considered for electrical work and design. Especially the power cable and circuit breaker should be selected in accordance with that.
 3. Power factor could vary less than ±1% according to the operating conditions.
 4. Sound pressure level is measured on the rated condition in the anechoic rooms by ISO 3745 standard. Sound power level is measured on the rated condition in the reverberation rooms by ISO 3741 standard. Therefore, these values can be increased owing to ambient conditions during operation.
 5. Performances are based on the following conditions : Cooling : Indoor Ambient Temp. 27°CDB / 19°CWB, Outdoor Ambient Temp. 35°CDB / 24°CWB
 Heating : Indoor Ambient Temp. 20°CDB / 15°CWB, Outdoor Ambient Temp. 7°CDB / 6°CWB
 Interconnected Pipe Length is 7.5m and difference of Elevation (Outdoor - Indoor Unit) is Zero.
 6. The numbers in parentheses means maximum connectable indoor units in accordance with outdoor units combination. The recommended ratio is 130%.
 7. This product contains Fluorinated greenhouse gases.(R410A, GWP(Global warming potential) = 2087.5)
 * Eurovent test Condition

MULTI V 5

Non TROPICAL MODEL

STANDARD

ARUN240LTE5 / ARUN260LTE5 / ARUN221LTE5 / ARUN241LTE5

LG participates in the ECP programme for EUROVENT VRF program. Check ongoing validity of certification : www.eurovent-certification.com



HP			24	26	22'	24'
Model Name	Combination Unit		ARUN240LTE5	ARUN260LTE5	ARUN221LTE5	ARUN241LTE5
	Independent Unit		ARUN240LTE5	ARUN260LTE5	ARUN120LTE5 ARUN100LTE5	ARUN120LTE5 ARUN120LTE5
Capacity	Cooling (Rated)	kW	67.2	72.8	61.6	67.2
		Btu/h	229,300	248,400	210,100	229,200
	Heating (Rated)	kW	74.3	74.3	69.3	75.6
		Btu/h	253,400	253,400	236,500	258,000
Input	Cooling (Rated)	kW	16.76	19.41	13.60	15.81
	Heating (Rated)	kW	18.85	19.49	13.80	16.12
Input ¹⁾	Cooling (Rated)	kW	14.9	20.49	16.8	23.79
	Heating (Rated)	kW	12.7	17.64	14.7	17.78
	Heating (Max)	kW	15.3	20.87	17.8	21.29
EER (Rated)			4.01	3.75	4.53	4.25
COP (Rated)			3.94	3.81	5.01	4.69
EER ¹⁾			3.28	3.06	4.14	3.99
ESEER			6.98	5.58	6.72	5.38
ESEER (SLC)			7.95	6.83	7.74	6.47
Power Factor	Rated	-	0.93	0.93	0.93	0.93
Exterior	Color		Warm Gray / Dawn Gray	Warm Gray / Dawn Gray	Warm Gray / Dawn Gray	Warm Gray / Dawn Gray
	RAL code		NL503K / NA507K	NL503K / NA507K	NL503K / NA507K	NL503K / NA507K
Heat Exchanger			Wide Louver Plus	Wide Louver Plus	Wide Louver Plus	Wide Louver Plus
Compressor	Motor Output x Number	W x No.	5,300 x 2	5,300 x 2	5,300 x 2	5,300 x 2
	Type		Propeller fan	Propeller fan	Propeller fan	Propeller fan
Fan	Motor Output x Number	W	900 x 2	900 x 2	(1,200 x 1) + (1,200 x 1)	(1,200 x 1) + (1,200 x 1)
	Air Flow Rate (High)	m ³ /min	320 x 1	320 x 1	(240 x 1) + (240 x 1)	(240 x 1) + (240 x 1)
		ft ³ /min	11,301 x 1	11,301 x 1	(8,476 x 1) + (8,476 x 1)	(8,476 x 1) + (8,476 x 1)
	External Static Pressure (Max, Pa)		80	80	80	80
	Drive		DC INVERTER	DC INVERTER	DC INVERTER	DC INVERTER
	Discharge	Side / Top	TOP	TOP	TOP	TOP
Pipe Connctions	Liquid Pipe	mm(inch)	15.88(5/8)	19.05(3/4)	15.88(5/8)	15.88(5/8)
	Gas Pipe	mm(inch)	34.9(1-3/8)	34.9(1-3/8)	28.58(1-1/8)	34.9(1-3/8)
Dimensions (W x H x D)	mm		(1,240 x 1,690 x 760) x 1	(1,240 x 1,690 x 760) x 1	(930 x 1,690 x 760) x 2	(930 x 1,690 x 760) x 2
Net Weight	kg		283 x 1	283 x 1	199 x 2	199 x 2
	lbs		624 x 1	624 x 1	439 x 2	439 x 2
Sound Pressure Level	Cooling	dB(A)	65.0	65.0	61.5	62.0
	Heating	dB(A)	67.0	67.0	62.5	63.0
Sound Power Level	Cooling	dB(A)	88.0	88.0	81.5	82.0
	Heating	dB(A)	90.0	90.0	82.5	83.0
Communication Cable	No.xmm ² (VCTF-SB)		2C x 1.0 - 1.5	2C x 1.0 - 1.5	2C x 1.0 - 1.5	2C x 1.0 - 1.5
Refrigerant	Refrigerant Name		R410A	R410A	R410A	R410A
	Precharged Amount in factory	kg	16.0	16.0	10.0 + 10.0	10.0 + 10.0
		lbs	35.3	35.3	22.0 + 22.0	22.0 + 22.0
	TCO ₂ eq		33.4	33.4	41.8	41.8
Power Supply	Control		Electronic Expansion Valve	Electronic Expansion Valve	Electronic Expansion Valve	Electronic Expansion Valve
	∅, V, Hz		380-415, 3, 50	380-415, 3, 50	380-415, 3, 50	380-415, 3, 50
Number of Maxmum Connectable Indoor Units			39(61)	42(64)	35(44)	39(48)

Note : 1. Due to our policy of innovation some specifications may be changed without notification.
 2. Wiring cable size must comply with the applicable local and national codes. And "Electric characteristics" chapter should be considered for electrical work and design. Especially the power cable and circuit breaker should be selected in accordance with that.
 3. Power factor could vary less than ±1% according to the operating conditions.
 4. Sound pressure level is measured on the rated condition in the anechoic rooms by ISO 3745 standard. Sound power level is measured on the rated condition in the reverberation rooms by ISO 3741 standard. Therefore, these values can be increased owing to ambient conditions during operation.
 5. Performances are based on the following conditions : Cooling : Indoor Ambient Temp. 27°CDB / 19°CWB, Outdoor Ambient Temp. 35°CDB / 24°CWB
 Heating : Indoor Ambient Temp. 20°CDB / 15°CWB, Outdoor Ambient Temp. 7°CDB / 6°CWB
 Interconnected Pipe Length is 7.5m and difference of Elevation (Outdoor - Indoor Unit) is Zero.
 6. The numbers in parentheses means maximum connectable indoor units in accordance with outdoor units combination. The recommended ratio is 130%.
 7. This product contains Fluorinated greenhouse gases.(R410A, GWP(Global warming potential) = 2087.5)
 * Eurovent test Condition

Non TROPICAL MODEL

STANDARD

ARUN261LTE5 / ARUN280LTE5 / ARUN300LTE5 / ARUN320LTE5



HP			26'	28	30	32
Model Name	Combination Unit		ARUN261LTE5	ARUN280LTE5	ARUN300LTE5	ARUN320LTE5
	Independent Unit		ARUN140LTE5 ARUN120LTE5	ARUN160LTE5 ARUN120LTE5	ARUN180LTE5 ARUN120LTE5	ARUN200LTE5 ARUN120LTE5
Capacity	Cooling (Rated)	kW	72.8	78.4	84.0	89.6
		Btu/h	248,400	267,500	286,600	305,700
	Heating (Rated)	kW	81.9	88.2	94.5	100.8
		Btu/h	279,500	301,000	322,500	344,000
Input	Cooling (Rated)	kW	17.02	18.70	18.86	20.21
	Heating (Rated)	kW	17.84	19.65	20.12	23.58
Input ¹⁾	Cooling (Rated)	kW	18.6	21.2	21.2	23.4
	Heating (Rated)	kW	16.4	18.8	18.6	20.9
	Heating (Max)	kW	19.7	22.7	22.2	25.2
EER (Rated)			4.28	4.19	4.45	4.43
COP (Rated)			4.59	4.49	4.70	4.28
EER ¹⁾			3.91	3.69	3.95	3.82
ESEER			6.45	6.04	6.46	6.24
ESEER (SLC)			7.34	7.06	7.20	6.94
Power Factor	Rated	-	0.93	0.93	0.93	0.93
Exterior	Color		Warm Gray / Dawn Gray	Warm Gray / Dawn Gray	Warm Gray / Dawn Gray	Warm Gray / Dawn Gray
	RAL code		NL503K / NA507K	NL503K / NA507K	NL503K / NA507K	NL503K / NA507K
Heat Exchanger			Wide Louver Plus	Wide Louver Plus	Wide Louver Plus	Wide Louver Plus
Compressor	Motor Output x Number	W x No.	5,300 x 2	5,300 x 2	(5,300 x 2) + (4,200 x 1)	(5,300 x 2) + (4,200 x 1)
	Type		Propeller fan	Propeller fan	Propeller fan	Propeller fan
Fan	Motor Output x Number	W	(900 x 2) + (1,200 x 1)	(900 x 2) + (1,200 x 1)	(900 x 2) + (1,200 x 1)	(900 x 2) + (1,200 x 1)
	Air Flow Rate (High)	m ³ /min	(320 x 1) + (240 x 1)	(320 x 1) + (240 x 1)	(320 x 1) + (240 x 1)	(320 x 1) + (240 x 1)
		ft ³ /min	(11,301 x 1) + (8,476 x 1)	(11,301 x 1) + (8,476 x 1)	(11,301 x 1) + (8,476 x 1)	(11,301 x 1) + (8,476 x 1)
	External Static Pressure (Max, Pa)		80	80	80	80
	Drive		DC INVERTER	DC INVERTER	DC INVERTER	DC INVERTER
	Discharge	Side / Top	TOP	TOP	TOP	TOP
Pipe Connctions	Liquid Pipe	mm(inch)	19.05(3/4)	19.05(3/4)	19.05(3/4)	19.05(3/4)
	Gas Pipe	mm(inch)	34.9(1-3/8)	34.9(1-3/8)	34.9(1-3/8)	34.9(1-3/8)
Dimensions (W x H x D)	mm		(1,240 x 1,690 x 760) x 1 + (930 x 1,690 x 760) x 1	(1,240 x 1,690 x 760) x 1 + (930 x 1,690 x 760) x 1	(1,240 x 1,690 x 760) x 1 + (930 x 1,690 x 760) x 1	(1,240 x 1,690 x 760) x 1 + (930 x 1,690 x 760) x 1
Net Weight	kg		(221 x 1) + (199 x 1)	(221 x 1) + (199 x 1)	(261 x 1) + (199 x 1)	(281 x 1) + (199 x 1)
	lbs		(487 x 1) + (439 x 1)	(487 x 1) + (439 x 1)	(575 x 1) + (439 x 1)	(619 x 1) + (439 x 1)
Sound Pressure Level	Cooling	dB(A)	62.5	62.8	63.1	63.8
	Heating	dB(A)	63.5	63.8	64.1	65.8
Sound Power Level	Cooling	dB(A)	83.8	84.5	86.0	86.8
	Heating	dB(A)	85.5	86.2	87.0	87.8
Communication Cable	No.xmm ² (VCTF-SB)		2C x 1.0 - 1.5	2C x 1.0 - 1.5	2C x 1.0 - 1.5	2C x 1.0 - 1.5
Refrigerant	Refrigerant Name		R410A	R410A	R410A	R410A
	Precharged Amount in factory	kg	13.0 + 10.0	13.0 + 10.0	13.0 + 10.0	14.0 + 10.0
		lbs	28.7 + 22.0	28.7 + 22.0	28.7 + 22.0	30.9 + 22.0
	TCO ₂ eq		48.0	48.0	48.0	50.1
Power Supply	Control		Electronic Expansion Valve	Electronic Expansion Valve	Electronic Expansion Valve	Electronic Expansion Valve
	∅, V, Hz		380-415, 3, 50	380-415, 3, 50	380-415, 3, 50	380-415, 3, 50
Number of Maxmum Connectable Indoor Units			42(52)	45(56)	49(60)	52(64)

Note : 1. Due to our policy of innovation some specifications may be changed without notification.
 2. Wiring cable size must comply with the applicable local and national codes. And "Electric characteristics" chapter should be considered for electrical work and design. Especially the power cable and circuit breaker should be selected in accordance with that.
 3. Power factor could vary less than ±1% according to the operating conditions.
 4. Sound pressure level is measured on the rated condition in the anechoic rooms by ISO 3745 standard. Sound power level is measured on the rated condition in the reverberation rooms by ISO 3741 standard. Therefore, these values can be increased owing to ambient conditions during operation.
 5. Performances are based on the following conditions : Cooling : Indoor Ambient Temp. 27°CDB / 19°CWB, Outdoor Ambient Temp. 35°CDB / 24°CWB
 Heating : Indoor Ambient Temp. 20°CDB / 15°CWB, Outdoor Ambient Temp. 7°CDB / 6°CWB
 Interconnected Pipe Length is 7.5m and difference of Elevation (Outdoor - Indoor Unit) is Zero.
 6. The numbers in parentheses means maximum connectable indoor units in accordance with outdoor units combination. The recommended ratio is 130%.
 7. This product contains Fluorinated greenhouse gases.(R410A, GWP(Global warming potential) = 2087.5)
 * Eurovent test Condition

OUTDOOR UNITS
INDOOR UNITS
HOT WATER SOLUTION
VENTILATION SOLUTIONS
CONTROL SOLUTIONS
ACCESSORIES

MULTI V 5

Non TROPICAL MODEL

STANDARD

ARUN340LTE5 / ARUN360LTE5 / ARUN380LTE5 / ARUN400LTE5



HP			34	36	38	40
Model Name	Combination Unit		ARUN340LTE5	ARUN360LTE5	ARUN380LTE5	ARUN400LTE5
	Independent Unit		ARUN220LTE5 ARUN120LTE5	ARUN240LTE5 ARUN120LTE5	ARUN240LTE5 ARUN140LTE5	ARUN240LTE5 ARUN160LTE5
Capacity	Cooling (Rated)	kW	95.2	100.8	106.4	112.0
		Btu/h	324,800	343,900	363,100	382,200
	Heating (Rated)	kW	107.1	112.1	118.4	124.7
		Btu/h	365,500	382,400	403,900	425,400
Input	Cooling (Rated)	kW	22.75	24.66	25.87	27.55
	Heating (Rated)	kW	25.60	26.91	28.62	30.43
Input ¹⁾	Cooling (Rated)	kW	26.9	28.9	30.7	33.3
	Heating (Rated)	kW	23.1	25.0	26.7	29.1
	Heating (Max)	kW	27.5	29.8	31.7	34.6
EER (Rated)			4.18	4.09	4.11	4.06
COP (Rated)			4.18	4.16	4.13	4.10
EER ¹⁾			3.54	3.49	3.47	3.36
ESEER			6.01	5.92	5.80	5.59
ESEER (SLC)			7.03	7.11	6.89	6.75
Power Factor	Rated	-	0.93	0.93	0.93	0.93
Exterior	Color		Warm Gray / Dawn Gray	Warm Gray / Dawn Gray	Warm Gray / Dawn Gray	Warm Gray / Dawn Gray
	RAL code		NL503K / NA507K	NL503K / NA507K	NL503K / NA507K	NL503K / NA507K
Heat Exchanger			Wide Louver Plus	Wide Louver Plus	Wide Louver Plus	Wide Louver Plus
Compressor	Motor Output x Number	W x No.	5,300 x 3	5,300 x 3	5,300 x 3	5,300 x 3
	Type		Propeller fan	Propeller fan	Propeller fan	Propeller fan
Fan	Motor Output x Number	W	(900 x 2) + (1,200 x 1)	(900 x 2) + (1,200 x 1)	900 x 4	900 x 4
	Air Flow Rate (High)	m ³ /min	(320 x 1) + (240 x 1)	(320 x 1) + (240 x 1)	320 x 2	320 x 2
		ft ³ /min	(11,301 x 1) + (8,476 x 1)	(11,301 x 1) + (8,476 x 1)	11,301 x 2	11,301 x 2
	External Static Pressure (Max, Pa)		80	80	80	80
	Drive		DC INVERTER	DC INVERTER	DC INVERTER	DC INVERTER
	Discharge	Side / Top	TOP	TOP	TOP	TOP
Pipe Connctions	Liquid Pipe	mm(inch)	19.05(3/4)	19.05(3/4)	19.05(3/4)	19.05(3/4)
	Gas Pipe	mm(inch)	34.9(1-3/8)	41.3(1-5/8)	41.3(1-5/8)	41.3(1-5/8)
Dimensions (W x H x D)	mm	(1,240 x 1,690 x 760) x 1 + (930 x 1,690 x 760) x 1	(1,240 x 1,690 x 760) x 1 + (930 x 1,690 x 760) x 1	(1,240 x 1,690 x 760) x 2	(1,240 x 1,690 x 760) x 2	
Net Weight	kg	(283 x 1) + (199 x 1)	(283 x 1) + (199 x 1)	(283 x 1) + (221 x 1)	(283 x 1) + (221 x 1)	
	lbs	(619 x 1) + (439 x 1)	(624 x 1) + (439 x 1)	(624 x 1) + (487 x 1)	(624 x 1) + (487 x 1)	
Sound Pressure Level	Cooling	dB(A)	65.6	66.0	66.2	66.3
	Heating	dB(A)	66.6	67.8	68.0	68.1
Sound Power Level	Cooling	dB(A)	86.8	88.5	89.0	89.2
	Heating	dB(A)	88.6	90.4	91.0	91.2
Communication Cable	No. x mm ² (VCTF-SB)		2C x 1.0 - 1.5	2C x 1.0 - 1.5	2C x 1.0 - 1.5	2C x 1.0 - 1.5
Refrigerant	Refrigerant Name		R410A	R410A	R410A	R410A
	Precharged Amount in factory	kg	14.0 + 10.0	16.0 + 10.0	16.0 + 13.0	16.0 + 13.0
		lbs	30.9 + 22.0	35.3 + 22.0	35.3 + 28.7	35.3 + 28.7
	TCO ₂ eq		50.1	54.3	60.5	60.5
Control			Electronic Expansion Valve	Electronic Expansion Valve	Electronic Expansion Valve	Electronic Expansion Valve
Power Supply	Ø, V, Hz		380-415, 3, 50	380-415, 3, 50	380-415, 3, 50	380-415, 3, 50
			380, 3, 60	380, 3, 60	380, 3, 60	380, 3, 60
Number of Maxmum Connectable Indoor Units			55(64)	58(64)	61(64)	64

- Note : 1. Due to our policy of innovation some specifications may be changed without notification.
 2. Wiring cable size must comply with the applicable local and national codes. And "Electric characteristics" chapter should be considered for electrical work and design. Especially the power cable and circuit breaker should be selected in accordance with that.
 3. Power factor could vary less than ±1% according to the operating conditions.
 4. Sound pressure level is measured on the rated condition in the anechoic rooms by ISO 3745 standard. Sound power level is measured on the rated condition in the reverberation rooms by ISO 3741 standard. Therefore, these values can be increased owing to ambient conditions during operation.
 5. Performances are based on the following conditions : Cooling : Indoor Ambient Temp. 27°CDB / 19°CWB, Outdoor Ambient Temp. 35°CDB / 24°CWB
 Heating : Indoor Ambient Temp. 20°CDB / 15°CWB, Outdoor Ambient Temp. 7°CDB / 6°CWB
 Interconnected Pipe Length is 7.5m and difference of Elevation (Outdoor - Indoor Unit) is Zero.
 6. The numbers in parentheses means maximum connectable indoor units in accordance with outdoor units combination. The recommended ratio is 130%.
 7. This product contains Fluorinated greenhouse gases.(R410A, GWP(Global warming potential) = 2087.5)
 * Eurovent test Condition

Non TROPICAL MODEL

STANDARD

ARUN420LTE5 / ARUN440LTE5 / ARUN460LTE5 / ARUN480LTE5



HP			42	44	46	48
Model Name	Combination Unit		ARUN420LTE5	ARUN440LTE5	ARUN460LTE5	ARUN480LTE5
	Independent Unit		ARUN240LTE5 ARUN180LTE5	ARUN240LTE5 ARUN200LTE5	ARUN240LTE5 ARUN220LTE5	ARUN240LTE5 ARUN240LTE5
Capacity	Cooling (Rated)	kW	117.6	123.2	128.8	134.4
		Btu/h	401,300	420,400	439,500	458,600
	Heating (Rated)	kW	131.0	137.3	143.6	148.5
		Btu/h	446,900	468,400	489,900	506,800
Input	Cooling (Rated)	kW	27.71	29.07	31.60	33.52
	Heating (Rated)	kW	30.91	34.36	36.39	37.69
Input ¹⁾	Cooling (Rated)	kW	33.3	35.5	38.9	41.0
	Heating (Rated)	kW	28.9	31.2	33.4	35.3
	Heating (Max)	kW	34.1	37.2	39.5	41.7
EER (Rated)			4.24	4.24	4.08	4.01
COP (Rated)			4.24	3.99	3.94	3.94
EER ¹⁾			3.53	3.47	3.31	3.28
ESEER			5.87	5.75	5.63	5.58
ESEER (SLC)			6.84	6.68	6.77	6.83
Power Factor	Rated	-	0.93	0.93	0.93	0.93
Exterior	Color		Warm Gray / Dawn Gray	Warm Gray / Dawn Gray	Warm Gray / Dawn Gray	Warm Gray / Dawn Gray
	RAL code		NL503K / NA507K	NL503K / NA507K	NL503K / NA507K	NL503K / NA507K
Heat Exchanger			Wide Louver Plus	Wide Louver Plus	Wide Louver Plus	Wide Louver Plus
Compressor	Motor Output x Number	W x No.	(5,300 x 3) + (4,200 x 1)	5,300 x 4	5,300 x 4	5,300 x 4
	Type		Propeller fan	Propeller fan	Propeller fan	Propeller fan
Fan	Motor Output x Number	W	900 x 4	900 x 4	900 x 4	900 x 4
	Air Flow Rate (High)	m ³ /min	320 x 2	320 x 2	320 x 2	320 x 2
		ft ³ /min	11,301 x 2	11,301 x 2	11,301 x 2	11,301 x 2
	External Static Pressure (Max, Pa)		80	80	80	80
	Drive		DC INVERTER	DC INVERTER	DC INVERTER	DC INVERTER
	Discharge	Side / Top	TOP	TOP	TOP	TOP
Pipe Connctions	Liquid Pipe	mm(inch)	19.05(3/4)	19.05(3/4)	19.05(3/4)	19.05(3/4)
	Gas Pipe	mm(inch)	41.3(1-5/8)	41.3(1-5/8)	41.3(1-5/8)	41.3(1-5/8)
Dimensions (W x H x D)	mm	(1,240 x 1,690 x 760) x 2	(1,240 x 1,690 x 760) x 2	(1,240 x 1,690 x 760) x 2	(1,240 x 1,690 x 760) x 2	
Net Weight	kg	(283 x 1) + (261 x 1)	(283 x 1) + (281 x 1)	(283 x 1) + (281 x 1)	283 x 2	
	lbs	(624 x 1) + (575 x 1)	(624 x 1) + (619 x 1)	(624 x 1) + (619 x 1)	624 x 2	
Sound Pressure Level	Cooling	dB(A)	66.5	66.8	67.8	68.0
	Heating	dB(A)	68.2	68.9	69.3	70.0
Sound Power Level	Cooling	dB(A)	89.8	90.1	90.1	91.0
	Heating	dB(A)	91.5	91.8	92.1	93.0
Communication Cable	No. x mm ² (VCTF-SB)		2C x 1.0 - 1.5	2C x 1.0 - 1.5	2C x 1.0 - 1.5	2C x 1.0 - 1.5
Refrigerant	Refrigerant Name		R410A	R410A	R410A	R410A
	Precharged Amount in factory	kg	16.0 + 13.0	16.0 + 14.0	16.0 + 14.0	16.0 + 16.0
		lbs	35.3 + 28.7	35.3 + 30.9	35.3 + 30.9	35.3 + 35.3
	TCO ₂ eq		60.5	62.6	62.6	66.8
Control			Electronic Expansion Valve	Electronic Expansion Valve	Electronic Expansion Valve	Electronic Expansion Valve
Power Supply	Ø, V, Hz		380-415, 3, 50	380-415, 3, 50	380-415, 3, 50	380-415, 3, 50
			380, 3, 60	380, 3, 60	380, 3, 60	380, 3, 60
Number of Maxmum Connectable Indoor Units			64	64	64	64

- Note : 1. Due to our policy of innovation some specifications may be changed without notification.
 2. Wiring cable size must comply with the applicable local and national codes. And "Electric characteristics" chapter should be considered for electrical work and design. Especially the power cable and circuit breaker should be selected in accordance with that.
 3. Power factor could vary less than ±1% according to the operating conditions.
 4. Sound pressure level is measured on the rated condition in the anechoic rooms by ISO 3745 standard. Sound power level is measured on the rated condition in the reverberation rooms by ISO 3741 standard. Therefore, these values can be increased owing to ambient conditions during operation.
 5. Performances are based on the following conditions : Cooling : Indoor Ambient Temp. 27°CDB / 19°CWB, Outdoor Ambient Temp. 35°CDB / 24°CWB
 Heating : Indoor Ambient Temp. 20°CDB / 15°CWB, Outdoor Ambient Temp. 7°CDB / 6°CWB
 Interconnected Pipe Length is 7.5m and difference of Elevation (Outdoor - Indoor Unit) is Zero.
 6. The numbers in parentheses means maximum connectable indoor units in accordance with outdoor units combination. The recommended ratio is 130%.
 7. This product contains Fluorinated greenhouse gases.(R410A, GWP(Global warming potential) = 2087.5)
 * Eurovent test Condition

MULTI V 5

Non TROPICAL MODEL

STANDARD

ARUN500LTE5 / ARUN520LTE5 / ARUN540LTE5 / ARUN560LTE5



HP			50	52	54	56
Model Name	Combination Unit		ARUN500LTE5	ARUN520LTE5	ARUN540LTE5	ARUN560LTE5
	Independent Unit		ARUN240LTE5 ARUN140LTE5 ARUN120LTE5	ARUN240LTE5 ARUN160LTE5 ARUN120LTE5	ARUN240LTE5 ARUN180LTE5 ARUN120LTE5	ARUN240LTE5 ARUN200LTE5 ARUN120LTE5
Capacity	Cooling (Rated)	kW	140.0	145.6	151.2	156.8
		Btu/h	477,700	496,800	515,900	535,000
	Heating (Rated)	kW	156.2	162.5	168.8	175.1
		Btu/h	532,900	554,400	575,900	597,400
Input	Cooling (Rated)	kW	33.78	35.46	35.62	36.97
		kW	36.68	38.49	38.97	42.42
Input ¹⁾	Cooling (Rated)	kW	39.1	41.7	41.7	43.9
		kW	34.0	36.4	36.3	38.6
		kW	40.6	43.5	43.0	46.1
EER (Rated)		4.14	4.11	4.24	4.24	
COP (Rated)		4.26	4.22	4.33	4.13	
EER ¹⁾		3.58	3.49	3.62	3.57	
ESEER		6.00	5.82	6.04	5.94	
ESEER (SLC)		7.08	6.95	7.02	6.89	
Power Factor	Rated	-	0.93	0.93	0.93	0.93
Exterior	Color		Warm Gray / Dawn Gray	Warm Gray / Dawn Gray	Warm Gray / Dawn Gray	Warm Gray / Dawn Gray
	RAL code		NL503K / NA507K	NL503K / NA507K	NL503K / NA507K	NL503K / NA507K
Heat Exchanger		Wide Louver Plus	Wide Louver Plus	Wide Louver Plus	Wide Louver Plus	
Compressor	Motor Output x Number	W x No.	5,300 x 4	5,300 x 4	(5,300 x 4) + (4,200 x 1)	5,300 x 5
	Type		Propeller fan	Propeller fan	Propeller fan	Propeller fan
Fan	Motor Output x Number	W	(900 x 4) + (1,200 x 1)	(900 x 4) + (1,200 x 1)	(900 x 4) + (1,200 x 1)	(900 x 4) + (1,200 x 1)
	Air Flow Rate (High)	m ³ /min	(320 x 2) + (240 x 1)	(320 x 2) + (240 x 1)	(320 x 2) + (240 x 1)	(320 x 2) + (240 x 1)
		ft ³ /min	(11,301 x 2) + (8,476 x 1)	(11,301 x 2) + (8,476 x 1)	(11,301 x 2) + (8,476 x 1)	(11,301 x 2) + (8,476 x 1)
	External Static Pressure (Max, Pa)		80	80	80	80
	Drive		DC INVERTER	DC INVERTER	DC INVERTER	DC INVERTER
Pipe Connctions	Liquid Pipe	mm(inch)	19.05(3/4)	19.05(3/4)	19.05(3/4)	19.05(3/4)
	Gas Pipe	mm(inch)	41.3(1-5/8)	41.3(1-5/8)	41.3(1-5/8)	41.3(1-5/8)
Dimensions (W x H x D)	mm	(1,240 x 1,690 x 760) x 2 + (930 x 1,690 x 760) x 1	(1,240 x 1,690 x 760) x 2 + (930 x 1,690 x 760) x 1	(1,240 x 1,690 x 760) x 2 + (930 x 1,690 x 760) x 1	(1,240 x 1,690 x 760) x 2 + (930 x 1,690 x 760) x 1	
Net Weight	kg	(283 x 1) + (221 x 1) + (199 x 1)	(283 x 1) + (221 x 1) + (199 x 1)	(283 x 1) + (261 x 1) + (199 x 1)	(283 x 1) + (281 x 1) + (199 x 1)	
	lbs	(624 x 1) + (487 x 1) + (439 x 1)	(624 x 1) + (487 x 1) + (439 x 1)	(624 x 1) + (575 x 1) + (439 x 1)	(624 x 1) + (619 x 1) + (439 x 1)	
Sound Pressure Level	Cooling	dB(A)	67.0	67.1	67.2	67.4
	Heating	dB(A)	68.6	68.7	68.8	69.5
Sound Power Level	Cooling	dB(A)	89.4	89.6	90.1	90.4
	Heating	dB(A)	91.3	91.5	91.8	92.0
Communication Cable	No. x mm ² (VCTF-SB)		2C x 1.0 - 1.5	2C x 1.0 - 1.5	2C x 1.0 - 1.5	2C x 1.0 - 1.5
Refrigerant	Refrigerant Name		R410A	R410A	R410A	R410A
	Precharged Amount in factory	kg	16.0 + 13.0 + 10.0	16.0 + 13.0 + 10.0	16.0 + 13.0 + 10.0	16.0 + 14.0 + 10.0
		lbs	35.3 + 28.7 + 22.0	35.3 + 28.7 + 22.0	35.3 + 28.7 + 22.0	35.3 + 30.9 + 22.0
	TCO ₂ eq		81.4	81.4	81.4	83.5
Control		Electronic Expansion Valve	Electronic Expansion Valve	Electronic Expansion Valve	Electronic Expansion Valve	
Power Supply	Ø, V, Hz		380-415, 3, 50	380-415, 3, 50	380-415, 3, 50	380-415, 3, 50
			380, 3, 60	380, 3, 60	380, 3, 60	380, 3, 60
Number of Maxmum Connectable Indoor Units		64	64	64	64	

- Note : 1. Due to our policy of innovation some specifications may be changed without notification.
 2. Wiring cable size must comply with the applicable local and national codes. And "Electric characteristics" chapter should be considered for electrical work and design. Especially the power cable and circuit breaker should be selected in accordance with that.
 3. Power factor could vary less than ±1% according to the operating conditions.
 4. Sound pressure level is measured on the rated condition in the anechoic rooms by ISO 3745 standard. Sound power level is measured on the rated condition in the reverberation rooms by ISO 3741 standard. Therefore, these values can be increased owing to ambient conditions during operation.
 5. Performances are based on the following conditions : Cooling : Indoor Ambient Temp. 27°CDB / 19°CWB, Outdoor Ambient Temp. 35°CDB / 24°CWB
 Heating : Indoor Ambient Temp. 20°CDB / 15°CWB, Outdoor Ambient Temp. 7°CDB / 6°CWB
 Interconnected Pipe Length is 7.5m and difference of Elevation (Outdoor - Indoor Unit) is Zero.
 6. The numbers in parentheses means maximum connectable indoor units in accordance with outdoor units combination. The recommended ratio is 130%.
 7. This product contains Fluorinated greenhouse gases.(R410A, GWP(Global warming potential) = 2087.5)
 * Eurovent test Condition

Non TROPICAL MODEL

STANDARD

ARUN580LTE5 / ARUN600LTE5 / ARUN620LTE5 / ARUN640LTE5



HP			58	60	62	64
Model Name	Combination Unit		ARUN580LTE5	ARUN600LTE5	ARUN620LTE5	ARUN640LTE5
	Independent Unit		ARUN240LTE5 ARUN220LTE5 ARUN120LTE5	ARUN240LTE5 ARUN240LTE5 ARUN120LTE5	ARUN240LTE5 ARUN240LTE5 ARUN140LTE5	ARUN240LTE5 ARUN240LTE5 ARUN160LTE5
Capacity	Cooling (Rated)	kW	162.4	168.0	173.6	179.2
		Btu/h	554,100	573,200	592,400	611,500
	Heating (Rated)	kW	181.4	186.3	192.6	198.9
		Btu/h	618,900	635,800	657,300	678,800
Input	Cooling (Rated)	kW	39.51	41.42	42.63	44.31
		kW	44.45	45.75	47.47	49.28
Input ¹⁾	Cooling (Rated)	kW	47.4	49.4	51.2	53.8
		kW	40.7	42.6	44.3	46.7
		kW	48.4	50.6	52.5	55.5
EER (Rated)		4.11	4.06	4.07	4.04	
COP (Rated)		4.08	4.07	4.06	4.04	
EER ¹⁾		3.43	3.40	3.39	3.33	
ESEER		5.83	5.78	5.71	5.59	
ESEER (SLC)		6.95	7.00	6.87	6.78	
Power Factor	Rated	-	0.93	0.93	0.93	0.93
Exterior	Color		Warm Gray / Dawn Gray	Warm Gray / Dawn Gray	Warm Gray / Dawn Gray	Warm Gray / Dawn Gray
	RAL code		NL503K / NA507K	NL503K / NA507K	NL503K / NA507K	NL503K / NA507K
Heat Exchanger		Wide Louver Plus	Wide Louver Plus	Wide Louver Plus	Wide Louver Plus	
Compressor	Motor Output x Number	W x No.	5,300 x 5	5,300 x 5	5,300 x 5	5,300 x 5
	Type		Propeller fan	Propeller fan	Propeller fan	Propeller fan
Fan	Motor Output x Number	W	(900 x 4) + (1,200 x 1)	(900 x 4) + (1,200 x 1)	900 x 6	900 x 6
	Air Flow Rate (High)	m ³ /min	(320 x 2) + (240 x 1)	(320 x 2) + (240 x 1)	320 x 3	320 x 3
		ft ³ /min	(11,301 x 2) + (8,476 x 1)	(11,301 x 2) + (8,476 x 1)	11,301 x 3	11,301 x 3
	External Static Pressure (Max, Pa)		80	80	80	80
	Drive		DC INVERTER	DC INVERTER	DC INVERTER	DC INVERTER
Pipe Connctions	Liquid Pipe	mm(inch)	19.05(3/4)	19.05(3/4)	22.2(7/8)	22.2(7/8)
	Gas Pipe	mm(inch)	41.3(1-5/8)	41.3(1-5/8)	44.5(1-3/4)	44.5(1-3/4)
Dimensions (W x H x D)	mm	(1,240 x 1,690 x 760) x 2 + (930 x 1,690 x 760) x 1	(1,240 x 1,690 x 760) x 2 + (930 x 1,690 x 760) x 1	(1,240 x 1,690 x 760) x 3	(1,240 x 1,690 x 760) x 3	
Net Weight	kg	(283 x 1) + (281 x 1) + (199 x 1)	(283 x 2) + (199 x 1)	(283 x 2) + (221 x 1)	(283 x 2) + (221 x 1)	
	lbs	(624 x 1) + (619 x 1) + (439 x 1)	(624 x 2) + (439 x 1)	(624 x 2) + (487 x 1)	(624 x 2) + (487 x 1)	
Sound Pressure Level	Cooling	dB(A)	68.3	68.5	68.6	68.7
	Heating	dB(A)	69.8	70.4	70.5	70.6
Sound Power Level	Cooling	dB(A)	90.4	91.3	91.5	91.6
	Heating	dB(A)	92.4	93.2	93.5	93.6
Communication Cable	No. x mm ² (VCTF-SB)		2C x 1.0 - 1.5	2C x 1.0 - 1.5	2C x 1.0 - 1.5	2C x 1.0 - 1.5
Refrigerant	Refrigerant Name		R410A	R410A	R410A	R410A
	Precharged Amount in factory	kg	16.0 + 14.0 + 10.0	16.0 + 16.0 + 10.0	16.0 + 16.0 + 13.0	16.0 + 16.0 + 13.0
		lbs	35.3 + 30.9 + 22.0	35.3 + 35.3 + 22.0	35.3 + 35.3 + 28.7	35.3 + 35.3 + 28.7
	TCO ₂ eq		83.5	87.7	93.9	93.9
Control		Electronic Expansion Valve	Electronic Expansion Valve	Electronic Expansion Valve	Electronic Expansion Valve	
Power Supply	Ø, V, Hz		380-415, 3, 50	380-415, 3, 50	380-415, 3, 50	380-415, 3, 50
			380, 3, 60	380, 3, 60	380, 3, 60	380, 3, 60
Number of Maxmum Connectable Indoor Units		64	64	64	64	

- Note : 1. Due to our policy of innovation some specifications may be changed without notification.
 2. Wiring cable size must comply with the applicable local and national codes. And "Electric characteristics" chapter should be considered for electrical work and design. Especially the power cable and circuit breaker should be selected in accordance with that.
 3. Power factor could vary less than ±1% according to the operating conditions.
 4. Sound pressure level is measured on the rated condition in the anechoic rooms by ISO 3745 standard. Sound power level is measured on the rated condition in the reverberation rooms by ISO 3741 standard. Therefore, these values can be increased owing to ambient conditions during operation.
 5. Performances are based on the following conditions : Cooling : Indoor Ambient Temp. 27°CDB / 19°CWB, Outdoor Ambient Temp. 35°CDB / 24°CWB
 Heating : Indoor Ambient Temp. 20°CDB / 15°CWB, Outdoor Ambient Temp. 7°CDB / 6°CWB
 Interconnected Pipe Length is 7.5m and difference of Elevation (Outdoor - Indoor Unit) is Zero.
 6. The numbers in parentheses means maximum connectable indoor units in accordance with outdoor units combination. The recommended ratio is 130%.
 7. This product contains Fluorinated greenhouse gases.(R410A, GWP(Global warming potential) = 2087.5)
 * Eurovent test Condition

MULTI V 5

Non TROPICAL MODEL

STANDARD

ARUN660LTE5 / ARUN680LTE5 / ARUN700LTE5 / ARUN720LTE5



HP			66	68	70	72
Model Name	Combination Unit		ARUN660LTE5	ARUN680LTE5	ARUN700LTE5	ARUN720LTE5
	Independent Unit		ARUN240LTE5 ARUN240LTE5 ARUN180LTE5	ARUN240LTE5 ARUN240LTE5 ARUN200LTE5	ARUN240LTE5 ARUN240LTE5 ARUN220LTE5	ARUN240LTE5 ARUN240LTE5 ARUN240LTE5
Capacity	Cooling (Rated)	kW	184.8	190.4	196.0	201.6
		Btu/h	630,600	649,700	668,800	687,900
	Heating (Rated)	kW	205.2	211.5	217.8	222.8
		Btu/h	700,300	721,800	743,300	760,200
Input	Cooling (Rated)	kW	44.47	45.82	48.36	50.27
	Heating (Rated)	kW	49.76	53.21	55.24	56.54
Input ¹⁾	Cooling (Rated)	kW	53.8	56.0	59.4	61.5
	Heating (Rated)	kW	46.5	48.8	51.0	52.9
	Heating (Max)	kW	55.0	58.1	60.3	62.6
EER (Rated)			4.16	4.16	4.05	4.01
COP (Rated)			4.12	3.97	3.94	3.94
EER ¹⁾			3.43	3.40	3.30	3.28
ESEER			5.76	5.69	5.61	5.58
ESEER (SLC)			6.84	6.73	6.79	6.83
Power Factor	Rated	-	0.93	0.93	0.93	0.93
Exterior	Color		Warm Gray / Dawn Gray	Warm Gray / Dawn Gray	Warm Gray / Dawn Gray	Warm Gray / Dawn Gray
	RAL code		NL503K / NA507K	NL503K / NA507K	NL503K / NA507K	NL503K / NA507K
Heat Exchanger			Wide Louver Plus	Wide Louver Plus	Wide Louver Plus	Wide Louver Plus
Compressor	Motor Output x Number	W x No.	(5,300 x 5) + (4,200 x 1)	5,300 x 6	5,300 x 6	5,300 x 6
	Type		Propeller fan	Propeller fan	Propeller fan	Propeller fan
Fan	Motor Output x Number	W	900 x 6	900 x 6	900 x 6	900 x 6
	Air Flow Rate (High)	m ³ /min	320 x 3	320 x 3	320 x 3	320 x 3
		ft ³ /min	11,301 x 3	11,301 x 3	11,301 x 3	11,301 x 3
	External Static Pressure (Max, Pa)		80	80	80	80
	Drive		DC INVERTER	DC INVERTER	DC INVERTER	DC INVERTER
	Discharge	Side / Top	TOP	TOP	TOP	TOP
Pipe Connctions	Liquid Pipe	mm(inch)	22.2(7/8)	22.2(7/8)	22.2(7/8)	22.2(7/8)
	Gas Pipe	mm(inch)	53.98(2-1/8)	53.98(2-1/8)	53.98(2-1/8)	53.98(2-1/8)
Dimensions (W x H x D)	mm		(1,240 x 1,690 x 760) x 3	(1,240 x 1,690 x 760) x 3	(1,240 x 1,690 x 760) x 3	(1,240 x 1,690 x 760) x 3
Net Weight	kg		(290 x 2) + (270 x 1)	(290 x 2) + (288 x 1)	(290 x 2) + (288 x 1)	290 x 3
	lbs		(639 x 2) + (595 x 1)	(639 x 2) + (635 x 1)	(639 x 2) + (635 x 1)	639 x 3
Sound Pressure Level	Cooling	dB(A)	68.8	69.0	69.6	69.8
	Heating	dB(A)	70.6	71.1	71.3	71.8
Sound Power Level	Cooling	dB(A)	92.0	92.2	92.2	92.8
	Heating	dB(A)	93.8	94.0	94.2	94.8
Communication Cable	No.xmm ² (VCTF-SB)		2C x 1.0 - 1.5	2C x 1.0 - 1.5	2C x 1.0 - 1.5	2C x 1.0 - 1.5
Refrigerant	Refrigerant Name		R410A	R410A	R410A	R410A
	Precharged Amount in factory	kg	16.0 + 16.0 + 13.0	16.0 + 16.0 + 14.0	16.0 + 16.0 + 14.0	16.0 + 16.0 + 16.0
	TCO ₂ eq	lbs	35.3 + 35.3 + 28.7	35.3 + 35.3 + 30.9	35.3 + 35.3 + 30.9	35.3 + 35.3 + 35.3
	Control		Electronic Expansion Valve	Electronic Expansion Valve	Electronic Expansion Valve	Electronic Expansion Valve
Power Supply	Ø, V, Hz		380-415, 3, 50	380-415, 3, 50	380-415, 3, 50	380-415, 3, 50
			380, 3, 60	380, 3, 60	380, 3, 60	380, 3, 60
Number of Maxmum Connectable Indoor Units			64	64	64	64

- Note : 1. Due to our policy of innovation some specifications may be changed without notification.
 2. Wiring cable size must comply with the applicable local and national codes. And "Electric characteristics" chapter should be considered for electrical work and design. Especially the power cable and circuit breaker should be selected in accordance with that.
 3. Power factor could vary less than ±1% according to the operating conditions.
 4. Sound pressure level is measured on the rated condition in the anechoic rooms by ISO 3745 standard. Sound power level is measured on the rated condition in the reverberation rooms by ISO 3741 standard. Therefore, these values can be increased owing to ambient conditions during operation.
 5. Performances are based on the following conditions : Cooling : Indoor Ambient Temp. 27°CDB / 19°CWB, Outdoor Ambient Temp. 35°CDB / 24°CWB
 Heating : Indoor Ambient Temp. 20°CDB / 15°CWB, Outdoor Ambient Temp. 7°CDB / 6°CWB
 Interconnected Pipe Length is 7.5m and difference of Elevation (Outdoor - Indoor Unit) is Zero.
 6. The numbers in parentheses means maximum connectable indoor units in accordance with outdoor units combination. The recommended ratio is 130%.
 7. This product contains Fluorinated greenhouse gases.(R410A, GWP(Global warming potential) = 2087.5)
 * Eurovent test Condition

Non TROPICAL MODEL

STANDARD

ARUN740LTE5 / ARUN760LTE5 / ARUN780LTE5 / ARUN800LTE5



HP			74	76	78	80
Model Name	Combination Unit		ARUN740LTE5	ARUN760LTE5	ARUN780LTE5	ARUN800LTE5
	Independent Unit		ARUN240LTE5 ARUN240LTE5 ARUN140LTE5 ARUN120LTE5	ARUN240LTE5 ARUN240LTE5 ARUN160LTE5 ARUN120LTE5	ARUN240LTE5 ARUN240LTE5 ARUN180LTE5 ARUN120LTE5	ARUN240LTE5 ARUN240LTE5 ARUN200LTE5 ARUN120LTE5
Capacity	Cooling (Rated)	kW	207.2	212.8	218.4	224.0
		Btu/h	707,000	726,100	745,200	764,300
	Heating (Rated)	kW	230.4	236.7	243.0	249.3
		Btu/h	786,300	807,800	829,300	850,800
Input	Cooling (Rated)	kW	50.54	52.22	52.38	53.73
	Heating (Rated)	kW	55.53	57.34	57.82	61.27
Input ¹⁾	Cooling (Rated)	kW	59.6	62.2	62.2	64.4
	Heating (Rated)	kW	51.7	54.1	53.9	56.2
	Heating (Max)	kW	61.4	64.4	63.9	66.9
EER (Rated)			4.10	4.08	4.17	4.17
COP (Rated)			4.15	4.13	4.20	4.07
EER ¹⁾			3.48	3.42	3.51	3.48
ESEER			5.86	5.74	5.89	5.83
ESEER (SLC)			7.00	6.91	6.96	6.87
Power Factor	Rated	-	0.93	0.93	0.93	0.93
Exterior	Color		Warm Gray / Dawn Gray	Warm Gray / Dawn Gray	Warm Gray / Dawn Gray	Warm Gray / Dawn Gray
	RAL code		NL503K / NA507K	NL503K / NA507K	NL503K / NA507K	NL503K / NA507K
Heat Exchanger			Wide Louver Plus	Wide Louver Plus	Wide Louver Plus	Wide Louver Plus
Compressor	Motor Output x Number	W x No.	5,300 x 6	5,300 x 6	(5,300 x 6) + (4,200 x 1)	5,300 x 7
	Type		Propeller fan	Propeller fan	Propeller fan	Propeller fan
Fan	Motor Output x Number	W	(900 x 6) + (1,200 x 1)	(900 x 6) + (1,200 x 1)	(900 x 6) + (1,200 x 1)	(900 x 6) + (1,200 x 1)
	Air Flow Rate (High)	m ³ /min	(320 x 3) + (240 x 1)	(320 x 3) + (240 x 1)	(320 x 3) + (240 x 1)	(320 x 3) + (240 x 1)
		ft ³ /min	(11,301 x 3) + (8,476 x 1)	(11,301 x 3) + (8,476 x 1)	(11,301 x 3) + (8,476 x 1)	(11,301 x 3) + (8,476 x 1)
	External Static Pressure (Max, Pa)		80	80	80	80
	Drive		DC INVERTER	DC INVERTER	DC INVERTER	DC INVERTER
	Discharge	Side / Top	TOP	TOP	TOP	TOP
Pipe Connctions	Liquid Pipe	mm(inch)	22.2(7/8)	22.2(7/8)	22.2(7/8)	22.2(7/8)
	Gas Pipe	mm(inch)	53.98(2-1/8)	53.98(2-1/8)	53.98(2-1/8)	53.98(2-1/8)
Dimensions (W x H x D)	mm		(1,240 x 1,690 x 760) x 3 + (930 x 1,690 x 760) x 1	(1,240 x 1,690 x 760) x 3 + (930 x 1,690 x 760) x 1	(1,240 x 1,690 x 760) x 3 + (930 x 1,690 x 760) x 1	(1,240 x 1,690 x 760) x 3 + (930 x 1,690 x 760) x 1
Net Weight	kg		(290 x 2) + (270 x 1) + (448 x 1)	(290 x 2) + (270 x 1) + (448 x 1)	(290 x 2) + (270 x 1) + (448 x 1)	(290 x 2) + (288 x 1) + (203 x 1)
	lbs		(639 x 2) + (507 x 1) + (448 x 1)	(639 x 2) + (507 x 1) + (448 x 1)	(639 x 2) + (595 x 1) + (448 x 1)	(639 x 2) + (635 x 1) + (448 x 1)
Sound Pressure Level	Cooling	dB(A)	69.1	69.2	69.2	69.4
	Heating	dB(A)	70.9	70.9	71.0	71.4
Sound Power Level	Cooling	dB(A)	91.8	91.9	92.2	92.4
	Heating	dB(A)	93.7	93.8	94.0	94.2
Communication Cable	No.xmm ² (VCTF-SB)		2C x 1.0 - 1.5	2C x 1.0 - 1.5	2C x 1.0 - 1.5	2C x 1.0 - 1.5
Refrigerant	Refrigerant Name		R410A	R410A	R410A	R410A
	Precharged Amount in factory	kg	16.0 + 16.0 + 13.0 + 10.0	16.0 + 16.0 + 13.0 + 10.0	16.0 + 16.0 + 13.0 + 10.0	16.0 + 16.0 + 14.0 + 10.0
	TCO ₂ eq	lbs	35.3 + 35.3 + 28.7 + 22.0	35.3 + 35.3 + 28.7 + 22.0	35.3 + 35.3 + 28.7 + 22.0	35.3 + 35.3 + 30.9 + 22.0
	Control		114.8	114.8	114.8	116.9
Power Supply	Ø, V, Hz		Electronic Expansion Valve	Electronic Expansion Valve	Electronic Expansion Valve	Electronic Expansion Valve
			380-415, 3, 50	380-415, 3, 50	380-415, 3, 50	380-415, 3, 50
Number of Maxmum Connectable Indoor Units			380, 3, 60	380, 3, 60	380, 3, 60	380, 3, 60
Number of Maxmum Connectable Indoor Units			64	64	64	64

- Note : 1. Due to our policy of innovation some specifications may be changed without notification.
 2. Wiring cable size must comply with the applicable local and national codes. And "Electric characteristics" chapter should be considered for electrical work and design. Especially the power cable and circuit breaker should be selected in accordance with that.
 3. Power factor could vary less than ±1% according to the operating conditions.
 4. Sound pressure level is measured on the rated condition in the anechoic rooms by ISO 3745 standard. Sound power level is measured on the rated condition in the reverberation rooms by ISO 3741 standard. Therefore, these values can be increased owing to ambient conditions during operation.
 5. Performances are based on the following conditions : Cooling : Indoor Ambient Temp. 27°CDB / 19°CWB, Outdoor Ambient Temp. 35°CDB / 24°CWB
 Heating : Indoor Ambient Temp. 20°CDB / 15°CWB, Outdoor Ambient Temp. 7°CDB / 6°CWB
 Interconnected Pipe Length is 7.5m and difference of Elevation (Outdoor - Indoor Unit) is Zero.
 6. The numbers in parentheses means maximum connectable indoor units in accordance with outdoor units combination. The recommended ratio is 130%.
 7. This product contains Fluorinated greenhouse gases.(R410A, GWP(Global warming potential) = 2087.5)
 * Eurovent test Condition

MULTI V 5

Non TROPICAL MODEL

STANDARD

ARUN820LTE5 / ARUN840LTE5
ARUN860LTE5 / ARUN880LTE5



HP			82	84	86	88
Model Name	Combination Unit		ARUN820LTE5	ARUN840LTE5	ARUN860LTE5	ARUN880LTE5
	Independent Unit		ARUN240LTE5 ARUN240LTE5 ARUN220LTE5 ARUN120LTE5	ARUN240LTE5 ARUN240LTE5 ARUN240LTE5 ARUN120LTE5	ARUN240LTE5 ARUN240LTE5 ARUN240LTE5 ARUN140LTE5	ARUN240LTE5 ARUN240LTE5 ARUN240LTE5 ARUN160LTE5
Capacity	Cooling (Rated)	kW	229.6	235.2	240.8	246.4
		Btu/h	783,400	802,500	821,700	840,800
	Heating (Rated)	kW	255.6	260.6	266.9	273.2
		Btu/h	872,300	889,200	910,700	932,200
Input	Cooling (Rated)	kW	56.27	58.18	59.39	61.07
	Heating (Rated)	kW	63.30	64.60	66.32	68.13
Input ¹⁾	Cooling (Rated)	kW	67.8	69.9	71.7	74.3
	Heating (Rated)	kW	58.4	60.3	61.9	64.3
	Heating (Max)	kW	69.2	71.5	73.4	76.4
EER (Rated)			4.08	4.04	4.05	4.03
COP (Rated)			4.04	4.03	4.02	4.01
EER ¹⁾			3.38	3.37	3.36	3.32
ESEER			5.75	5.72	5.68	5.59
ESEER (SLC)			6.91	6.95	6.86	6.79
Power Factor	Rated	-	0.93	0.93	0.93	0.93
Exterior	Color		Warm Gray / Dawn Gray	Warm Gray / Dawn Gray	Warm Gray / Dawn Gray	Warm Gray / Dawn Gray
	RAL code		NL503K / NA507K	NL503K / NA507K	NL503K / NA507K	NL503K / NA507K
Heat Exchanger			Wide Louver Plus	Wide Louver Plus	Wide Louver Plus	Wide Louver Plus
Compressor	Motor Output x Number	W x No.	5,300 x 7	5,300 x 7	5,300 x 7	5,300 x 7
	Type		Propeller fan	Propeller fan	Propeller fan	Propeller fan
Fan	Motor Output x Number	W	(900 x 6) + (1,200 x 1)	(900 x 6) + (1,200 x 1)	900 x 8	900 x 8
	Air Flow Rate (High)	m ³ /min	(320 x 3) + (240 x 1)	(320 x 3) + (240 x 1)	320 x 4	320 x 4
		ft ³ /min	(11,301 x 3) + (8,476 x 1)	(11,301 x 3) + (8,476 x 1)	11,301 x 4	11,301 x 4
	External Static Pressure (Max, Pa)		80	80	80	80
	Drive		DC INVERTER	DC INVERTER	DC INVERTER	DC INVERTER
	Discharge	Side / Top	TOP	TOP	TOP	TOP
Pipe Connctions	Liquid Pipe	mm(inch)	22.2(7/8)	22.2(7/8)	22.2(7/8)	22.2(7/8)
	Gas Pipe	mm(inch)	53.98(2-1/8)	53.98(2-1/8)	53.98(2-1/8)	53.98(2-1/8)
Dimensions (W x H x D)	mm		(1,240 x 1,690 x 760) x 3 + (930 x 1,690 x 760) x 1	(1,240 x 1,690 x 760) x 3 + (930 x 1,690 x 760) x 1	(1,240 x 1,690 x 760) x 4	(1,240 x 1,690 x 760) x 4
	kg		(283 x 2) + (281 x 1) + (199 x 1)	(283 x 2) + (281 x 1) + (199 x 1)	(283 x 3) + (221 x 1)	(283 x 3) + (221 x 1)
Net Weight	lbs		(624 x 2) + (619 x 1) + (439 x 1)	(624 x 2) + (619 x 1) + (439 x 1)	(624 x 3) + (487 x 1)	(624 x 3) + (487 x 1)
Sound Pressure Level	Cooling	dB(A)	70.0	70.1	70.2	70.3
	Heating	dB(A)	71.6	72.1	72.1	72.2
Sound Power Level	Cooling	dB(A)	92.4	92.9	93.1	93.2
	Heating	dB(A)	94.4	94.9	95.1	95.2
Communication Cable	No. x mm ² (VCTF-SB)		2C x 1.0 - 1.5	2C x 1.0 - 1.5	2C x 1.0 - 1.5	2C x 1.0 - 1.5
Refrigerant	Refrigerant Name		R410A	R410A	R410A	R410A
	Precharged Amount in factory	kg	16.0 + 16.0 + 14.0 + 10.0	16.0 + 16.0 + 16.0 + 10.0	16.0 + 16.0 + 16.0 + 13.0	16.0 + 16.0 + 16.0 + 13.0
		lbs	35.3 + 35.3 + 30.9 + 22.0	35.3 + 35.3 + 35.3 + 22.0	35.3 + 35.3 + 35.3 + 28.7	35.3 + 35.3 + 35.3 + 28.7
	TCO ₂ eq		116.9	121.1	127.3	127.3
	Control		Electronic Expansion Valve	Electronic Expansion Valve	Electronic Expansion Valve	Electronic Expansion Valve
Power Supply	∅, V, Hz		380-415, 3, 50	380-415, 3, 50	380-415, 3, 50	380-415, 3, 50
			380, 3, 60	380, 3, 60	380, 3, 60	380, 3, 60
Number of Maxmum Connectable Indoor Units			64	64	64	64

- Note : 1. Due to our policy of innovation some specifications may be changed without notification.
 2. Wiring cable size must comply with the applicable local and national codes. And "Electric characteristics" chapter should be considered for electrical work and design. Especially the power cable and circuit breaker should be selected in accordance with that.
 3. Power factor could vary less than ±1% according to the operating conditions.
 4. Sound pressure level is measured on the rated condition in the anechoic rooms by ISO 3745 standard. Sound power level is measured on the rated condition in the reverberation rooms by ISO 3741 standard. Therefore, these values can be increased owing to ambient conditions during operation.
 5. Performances are based on the following conditions : Cooling : Indoor Ambient Temp. 27°CDB / 19°CWB, Outdoor Ambient Temp. 35°CDB / 24°CWB
 Heating : Indoor Ambient Temp. 20°CDB / 15°CWB, Outdoor Ambient Temp. 7°CDB / 6°CWB
 Interconnected Pipe Length is 7.5m and difference of Elevation (Outdoor - Indoor Unit) is Zero.
 6. The numbers in parentheses means maximum connectable indoor units in accordance with outdoor units combination. The recommended ratio is 130%.
 7. This product contains Fluorinated greenhouse gases.(R410A, GWP(Global warming potential) = 2087.5)
 * Eurovent test Condition

Non TROPICAL MODEL

STANDARD

ARUN900LTE5 / ARUN920LTE5 / ARUN940LTE5 / ARUN960LTE5



HP			90	92	94	96
Model Name	Combination Unit		ARUN900LTE5	ARUN920LTE5	ARUN940LTE5	ARUN960LTE5
	Independent Unit		ARUN240LTE5 ARUN240LTE5 ARUN240LTE5 ARUN180LTE5	ARUN240LTE5 ARUN240LTE5 ARUN240LTE5 ARUN200LTE5	ARUN240LTE5 ARUN240LTE5 ARUN240LTE5 ARUN200LTE5	ARUN240LTE5 ARUN240LTE5 ARUN240LTE5 ARUN240LTE5
Capacity	Cooling (Rated)	kW	252.0	257.6	263.2	268.8
		Btu/h	859,900	879,000	898,100	917,200
	Heating (Rated)	kW	279.5	285.8	292.1	297.0
		Btu/h	953,700	975,200	996,700	1,013,600
Input	Cooling (Rated)	kW	61.23	62.58	65.12	67.03
	Heating (Rated)	kW	68.60	72.06	74.08	75.39
Input ¹⁾	Cooling (Rated)	kW	74.3	76.5	79.9	82.0
	Heating (Rated)	kW	64.2	66.5	68.6	70.6
	Heating (Max)	kW	75.9	78.9	81.2	83.5
EER (Rated)			4.12	4.12	4.04	4.01
COP (Rated)			4.07	3.97	3.94	3.94
EER ¹⁾			3.39	3.37	3.29	3.28
ESEER			5.71	5.66	5.61	5.58
ESEER (SLC)			6.83	6.76	6.80	6.83
Power Factor	Rated	-	0.93	0.93	0.93	0.93
Exterior	Color		Warm Gray / Dawn Gray	Warm Gray / Dawn Gray	Warm Gray / Dawn Gray	Warm Gray / Dawn Gray
	RAL code		NL503K / NA507K	NL503K / NA507K	NL503K / NA507K	NL503K / NA507K
Heat Exchanger			Wide Louver Plus	Wide Louver Plus	Wide Louver Plus	Wide Louver Plus
Compressor	Motor Output x Number	W x No.	(5,300 x 7) + (4,200 x 1)	5,300 x 8	5,300 x 8	5,300 x 8
	Type		Propeller fan	Propeller fan	Propeller fan	Propeller fan
Fan	Motor Output x Number	W	900 x 8	900 x 8	900 x 8	900 x 8
	Air Flow Rate (High)	m ³ /min	320 x 4	320 x 4	320 x 4	320 x 4
		ft ³ /min	11,301 x 4	11,301 x 4	11,301 x 4	11,301 x 4
	External Static Pressure (Max, Pa)		80	80	80	80
	Drive		DC INVERTER	DC INVERTER	DC INVERTER	DC INVERTER
	Discharge	Side / Top	TOP	TOP	TOP	TOP
Pipe Connctions	Liquid Pipe	mm(inch)	22.2(7/8)	22.2(7/8)	22.2(7/8)	22.2(7/8)
	Gas Pipe	mm(inch)	53.98(2-1/8)	53.98(2-1/8)	53.98(2-1/8)	53.98(2-1/8)
Dimensions (W x H x D)	mm		(1,240 x 1,690 x 760) x 4	(1,240 x 1,690 x 760) x 4	(1,240 x 1,690 x 760) x 4	(1,240 x 1,690 x 760) x 4
	kg		(283 x 3) + (261 x 1)	(283 x 3) + (281 x 1)	(283 x 3) + (281 x 1)	283 x 4
Net Weight	lbs		(624 x 3) + (575 x 1)	(624 x 3) + (619 x 1)	(624 x 3) + (619 x 1)	624 x 4
Sound Pressure Level	Cooling	dB(A)	70.3	70.4	70.9	71.0
	Heating	dB(A)	72.2	72.5	72.7	73.0
Sound Power Level	Cooling	dB(A)	93.4	93.6	93.6	94.0
	Heating	dB(A)	95.3	95.4	95.6	96.0
Communication Cable	No. x mm ² (VCTF-SB)		2C x 1.0 - 1.5	2C x 1.0 - 1.5	2C x 1.0 - 1.5	2C x 1.0 - 1.5
Refrigerant	Refrigerant Name		R410A	R410A	R410A	R410A
	Precharged Amount in factory	kg	16.0 + 16.0 + 16.0 + 13.0	16.0 + 16.0 + 16.0 + 14.0	16.0 + 16.0 + 16.0 + 14.0	16.0 + 16.0 + 16.0 + 16.0
		lbs	35.3 + 35.3 + 35.3 + 28.7	35.3 + 35.3 + 35.3 + 30.9	35.3 + 35.3 + 35.3 + 30.9	35.3 + 35.3 + 35.3 + 35.3
	TCO ₂ eq		127.3	129.4	129.4	133.6
	Control		Electronic Expansion Valve	Electronic Expansion Valve	Electronic Expansion Valve	Electronic Expansion Valve
Power Supply	∅, V, Hz		380-415, 3, 50	380-415, 3, 50	380-415, 3, 50	380-415, 3, 50
			380, 3, 60	380, 3, 60	380, 3, 60	380, 3, 60
Number of Maxmum Connectable Indoor Units			64	64	64	64

- Note : 1. Due to our policy of innovation some specifications may be changed without notification.
 2. Wiring cable size must comply with the applicable local and national codes. And "Electric characteristics" chapter should be considered for electrical work and design. Especially the power cable and circuit breaker should be selected in accordance with that.
 3. Power factor could vary less than ±1% according to the operating conditions.
 4. Sound pressure level is measured on the rated condition in the anechoic rooms by ISO 3745 standard. Sound power level is measured on the rated condition in the reverberation rooms by ISO 3741 standard. Therefore, these values can be increased owing to ambient conditions during operation.
 5. Performances are based on the following conditions : Cooling : Indoor Ambient Temp. 27°CDB / 19°CWB, Outdoor Ambient Temp. 35°CDB / 24°CWB
 Heating : Indoor Ambient Temp. 20°CDB / 15°CWB, Outdoor Ambient Temp. 7°CDB / 6°CWB
 Interconnected Pipe Length is 7.5m and difference of Elevation (Outdoor - Indoor Unit) is Zero.
 6. The numbers in parentheses means maximum connectable indoor units in accordance with outdoor units combination. The recommended ratio is 130%.
 7. This product contains Fluorinated greenhouse gases.(R410A, GWP(Global warming potential) = 2087.5)
 * Eurovent test Condition

MULTI V 5

TROPICAL MODEL

HIGH EFFICIENCY

ARUN080LEH5 / ARUN100LEH5 / ARUN120LEH5 / ARUN140LEH5



HP			8	10	12	14
Model Name	Combination Unit		ARUN080LEH5	ARUN100LEH5	ARUN120LEH5	ARUN140LEH5
	Independent Unit		ARUN080LEH5	ARUN100LEH5	ARUN120LEH5	ARUN140LEH5
Capacity (Rated) ¹⁾	*Cooling - T1 35°C	RT	6.4	8.0	9.5	11.1
		kW	22.4	28.0	33.6	39.2
		Btu/h	76,400	95,500	114,600	133,800
	**Cooling - T3 46°C	RT	5.7	7.2	9.4	11.0
		kW	20.2	25.5	33.0	38.8
		Btu/h	68,800	87,000	112,600	132,400
	Heating	RT	7.2	8.9	10.7	12.5
		kW	25.2	31.5	37.8	43.9
		Btu/h	86,000	107,500	129,000	149,900
Input (Rated) ¹⁾	*Cooling - T1 35°C	kW	4.52	5.58	7.53	9.10
	**Cooling - T3 46°C	kW	6.20	7.75	9.60	11.78
	Heating	kW	4.88	5.68	7.58	9.69
COP ¹⁾	*Cooling - T1 35°C	kW/kW	4.96	5.02	4.46	4.31
	**Cooling - T3 46°C	kW/kW	3.25	3.29	3.44	3.29
	Heating	kW/kW	5.16	5.55	4.99	4.53
Power Factor	Rated	-	0.93	0.93	0.93	0.93
Casing	Color		Warm Gray / Dawn Gray	Warm Gray / Dawn Gray	Warm Gray / Dawn Gray	Warm Gray / Dawn Gray
Heat Exchanger			Wide Louver Plus	Wide Louver Plus	Wide Louver Plus	Wide Louver Plus
Compressor	Type		Hermetically Sealed Scroll	Hermetically Sealed Scroll	Hermetically Sealed Scroll	Hermetically Sealed Scroll
	Piston Displacement	cm ³ /rev	62	62	62	62
	Number of Revolution	rev/min	3,600	3,600	3,600	3,600
	Motor Output x Number	W x No.	5,300 x 1	5,300 x 1	5,300 x 1	5,300 x 1
	Starting Method		Direct On Line	Direct On Line	Direct On Line	Direct On Line
	Oil Type		FVC68D(PVE)	FVC68D(PVE)	FVC68D(PVE)	FVC68D(PVE)
Fan	Type		Propeller fan	Propeller fan	Propeller fan	Propeller fan
	Motor Output x Number	W	1,200 x 1	1,200 x 1	900 x 2	900 x 2
	Air Flow Rate (High)	m ³ /min	240 x 1	240 x 1	320 x 1	320 x 1
		ft ³ /min	8,476 x 1	8,476 x 1	11,301 x 1	11,301 x 1
Pipe Connections	Liquid Pipe	mm(inch)	9.52(3/8)	9.52(3/8)	12.7(1/2)	12.7(1/2)
	Gas Pipe	mm(inch)	19.05(3/4)	22.2(7/8)	28.58(1-1/8)	28.58(1-1/8)
		mm	(930 x 1,690 x 760) x 1	(930 x 1,690 x 760) x 1	(1,240 x 1,690 x 760) x 1	(1,240 x 1,690 x 760) x 1
Dimensions (W x H x D)		inch	(36-5/8 x 66-17/32 x 29-29/32) x 1	(36-5/8 x 66-17/32 x 29-29/32) x 1	(48-13/16 x 66-17/32 x 29-29/32) x 1	(48-13/16 x 66-17/32 x 29-29/32) x 1
	Net Weight	kg	200 x 1	200 x 1	221 x 1	221 x 1
Sound Pressure Level	Cooling	dB(A)	58.0	58.0	59.0	60.0
	Heating	dB(A)	59.0	59.0	60.0	61.0
Sound Power Level	Cooling	dB(A)	77.0	78.0	79.0	82.0
	Heating	dB(A)	78.0	79.0	80.0	84.0
Communication Cable	No. x mm ² (VCTF-SB)		2C x 1.0 - 1.5	2C x 1.0 - 1.5	2C x 1.0 - 1.5	2C x 1.0 - 1.5
Refrigerant	Refrigerant Name		R410A	R410A	R410A	R410A
	Precharged Amount	kg	10.0	10.0	13.0	13.0
		lbs	22.0	22.0	28.7	28.7
Power Supply	Control		Electronic Expansion Valve	Electronic Expansion Valve	Electronic Expansion Valve	Electronic Expansion Valve
	Ø, V, Hz		380-415, 3, 50	380-415, 3, 50	380-415, 3, 50	380-415, 3, 50
Number of Maximum Connectable Indoor Units			13(20)	16(25)	23(35)	23(35)

TROPICAL MODEL

HIGH EFFICIENCY

ARUN160LEH5 / ARUN180LEH5 / ARUN200LEH5 / ARUN220LEH5



HP			16	18	20	22
Model Name	Combination Unit		ARUN160LEH5	ARUN180LEH5	ARUN200LEH5	ARUN220LEH5
	Independent Unit		ARUN160LEH5	ARUN180LEH5	ARUN200LEH5	ARUN120LEH5 ARUN100LEH5
Capacity (Rated) ¹⁾	*Cooling - T1 35°C	RT	12.7	14.3	15.9	17.5
		kW	44.8	50.4	56.0	61.6
		Btu/h	152,900	172,000	191,100	210,200
	**Cooling - T3 46°C	RT	11.5	12.9	13.9	16.6
		kW	40.3	45.4	49.0	58.5
		Btu/h	137,600	154,900	167,200	199,600
	Heating	RT	14.2	16.1	17.9	19.7
		kW	50.0	56.7	63.0	69.3
		Btu/h	170,600	193,500	215,000	236,500
Input (Rated) ¹⁾	*Cooling - T1 35°C	kW	9.87	10.72	12.50	13.11
	**Cooling - T3 46°C	kW	12.80	13.91	15.77	17.35
	Heating	kW	10.30	13.34	15.52	13.26
COP ¹⁾	*Cooling - T1 35°C	kW/kW	4.54	4.70	4.48	4.70
	**Cooling - T3 46°C	kW/kW	3.15	3.26	3.11	3.37
	Heating	kW/kW	4.85	4.25	4.06	5.23
Power Factor	Rated	-	0.93	0.93	0.93	0.93
Casing	Color		Warm Gray / Dawn Gray	Warm Gray / Dawn Gray	Warm Gray / Dawn Gray	Warm Gray / Dawn Gray
Heat Exchanger			Wide Louver Plus	Wide Louver Plus	Wide Louver Plus	Wide Louver Plus
Compressor	Type		Hermetically Sealed Scroll	Hermetically Sealed Scroll	Hermetically Sealed Scroll	Hermetically Sealed Scroll
	Piston Displacement	cm ³ /rev	62.1 x 1 + 43.8 x 1	62.1 x 2	62.1 x 2	62.1 x 2
	Number of Revolution	rev/min	3,600 x 2	3,600 x 2	3,600 x 2	3,600 x 2
	Motor Output x Number	W x No.	5,300 x 1 + 4,200 x 1	5,300 x 2	5,300 x 2	5,300 x 2
	Starting Method		Direct On Line	Direct On Line	Direct On Line	Direct On Line
	Oil Type		FVC68D(PVE)	FVC68D(PVE)	FVC68D(PVE)	FVC68D(PVE)
Fan	Type		Propeller fan	Propeller fan	Propeller fan	Propeller fan
	Motor Output x Number	W	900 x 2	900 x 2	900 x 2	(900 x 2) + (1,200 x 1)
	Air Flow Rate (High)	m ³ /min	320 x 1	320 x 1	320 x 1	(320 x 1) + (240 x 1)
		ft ³ /min	11,301 x 1	11,301 x 1	11,301 x 1	(11,301 x 1) + (8,476 x 1)
Pipe Connections	Liquid Pipe	mm(inch)	12.7(1/2)	15.88(5/8)	15.88(5/8)	15.88(5/8)
	Gas Pipe	mm(inch)	28.58(1-1/8)	28.58(1-1/8)	28.58(1-1/8)	28.58(1-1/8)
		mm	(1,240 x 1,690 x 760) x 1	(1,240 x 1,690 x 760) x 1	(1,240 x 1,690 x 760) x 1	(1,240 x 1,690 x 760) x 1 + (930 x 1,690 x 760) x 1
Dimensions (W x H x D)		inch	(48-13/16 x 66-17/32 x 29-29/32) x 1	(48-13/16 x 66-17/32 x 29-29/32) x 1	(48-13/16 x 66-17/32 x 29-29/32) x 1	(48-13/16 x 66-17/32 x 29-29/32) x 1 + (36-5/8 x 66-17/32 x 29-29/32) x 1
	Net Weight	kg	261 x 1	281 x 1	281 x 1	(221 x 1) + (200 x 1)
Sound Pressure Level	Cooling	dB(A)	60.5	61.0	62.0	61.5
	Heating	dB(A)	61.5	62.0	64.5	62.5
Sound Power Level	Cooling	dB(A)	83.0	85.0	86.0	81.5
	Heating	dB(A)	85.0	86.0	87.0	82.5
Communication Cable	No. x mm ² (VCTF-SB)		2C x 1.0 - 1.5	2C x 1.0 - 1.5	2C x 1.0 - 1.5	2C x 1.0 - 1.5
Refrigerant	Refrigerant Name		R410A	R410A	R410A	R410A
	Precharged Amount	kg	12.0	14.0	14.0	23.0
		lbs	26.5	30.9	30.9	50.7
Power Supply	Control		Electronic Expansion Valve	Electronic Expansion Valve	Electronic Expansion Valve	Electronic Expansion Valve
	Ø, V, Hz		380-415, 3, 50	380-415, 3, 50	380-415, 3, 50	380-415, 3, 50
Number of Maximum Connectable Indoor Units			26(40)	29(45)	32(50)	35(56)

MULTI V 5

TROPICAL MODEL

HIGH EFFICIENCY

ARUN240LEH5 / ARUN260LEH5 / ARUN280LEH5 / ARUN300LEH5



HP			24	26	28	30
Model Name	Combination Unit		ARUN240LEH5	ARUN260LEH5	ARUN280LEH5	ARUN300LEH5
	Independent Unit		ARUN140LEH5 ARUN100LEH5	ARUN140LEH5 ARUN120LEH5	ARUN140LEH5 ARUN140LEH5	ARUN160LEH5 ARUN140LEH5
Capacity (Rated) ¹⁾	*Cooling - T1 35°C	RT	2	2	2	2
		kW	19.1	20.7	22.3	23.9
		Btu/h	67.2	72.8	78.4	84.0
	**Cooling - T3 46°C	RT	18.3	20.4	22.0	22.5
		kW	64.3	71.8	77.6	79.1
		Btu/h	219,400	245,000	264,800	270,000
	Heating	RT	21.4	23.2	24.9	26.7
		kW	75.4	81.7	87.8	93.9
		Btu/h	257,300	278,800	299,700	320,500
Input (Rated) ¹⁾	*Cooling - T1 35°C	kW	14.68	16.63	18.20	18.97
	**Cooling - T3 46°C	kW	19.53	21.38	23.56	24.58
	Heating	kW	15.37	17.27	19.38	19.99
COP ¹⁾	*Cooling - T1 35°C	kW/kW	4.58	4.38	4.31	4.43
	**Cooling - T3 46°C	kW/kW	3.29	3.36	3.29	3.22
	Heating	kW/kW	4.91	4.73	4.53	4.70
Power Factor	Rated	-	0.93	0.93	0.93	0.93
Casing	Color		Warm Gray / Dawn Gray	Warm Gray / Dawn Gray	Warm Gray / Dawn Gray	Warm Gray / Dawn Gray
Heat Exchanger			Wide Louver Plus	Wide Louver Plus	Wide Louver Plus	Wide Louver Plus
Compressor	Type		Hermetically Sealed Scroll	Hermetically Sealed Scroll	Hermetically Sealed Scroll	Hermetically Sealed Scroll
	Piston Displacement	cm ³ /rev	62.1 x 2	62.1 x 2	62.1 x 2	(62.1 x 2) + (43.8 x 1)
	Number of Revolution	rev/min	3,600 x 2	3,600 x 2	3,600 x 2	3,600 x 3
	Motor Output x Number	W x No.	5,300 x 2	5,300 x 2	5,300 x 2	(5,300 x 2) + (4,200 x 1)
	Starting Method		Direct On Line	Direct On Line	Direct On Line	Direct On Line
	Oil Type		FVC68D(PVE)	FVC68D(PVE)	FVC68D(PVE)	FVC68D(PVE)
Fan	Type		Propeller fan	Propeller fan	Propeller fan	Propeller fan
	Motor Output x Number	W	(900 x 2) + (1,200 x 1)	900 x 4	900 x 4	900 x 4
	Air Flow Rate (High)	m ³ /min	(320 x 1) + (240 x 1)	320 x 2	320 x 2	320 x 2
		ft ³ /min	(11,301 x 1) + (8,476 x 1)	11,301 x 2	11,301 x 2	11,301 x 2
	Drive		DC INVERTER	DC INVERTER	DC INVERTER	DC INVERTER
Pipe Connections	Discharge	Side / Top	TOP	TOP	TOP	TOP
	Liquid Pipe	mm(inch)	15.88(5/8)	19.05(3/4)	19.05(3/4)	19.05(3/4)
	Gas Pipe	mm(inch)	34.9(1-3/8)	34.9(1-3/8)	34.9(1-3/8)	34.9(1-3/8)
Dimensions (W x H x D)		mm	(1,240 x 1,690 x 760) x 1 + (930 x 1,690 x 760) x 1	(1,240 x 1,690 x 760) x 2	(1,240 x 1,690 x 760) x 2	(1,240 x 1,690 x 760) x 2
		inch	(48-13/16 x 66-17/32 x 29-29/32) x 1 + (36-5/8 x 66-17/32 x 29-29/32) x 1	(48-13/16 x 66-17/32 x 29-29/32) x 2	(48-13/16 x 66-17/32 x 29-29/32) x 2	(48-13/16 x 66-17/32 x 29-29/32) x 2
Net Weight		kg	(221 x 1) + (200 x 1)	221 x 2	221 x 2	(261 x 1) + (221 x 1)
		lbs	(487 x 1) + (441 x 1)	487 x 2	487 x 2	(575 x 1) + (487 x 1)
Sound Pressure Level	Cooling	dB(A)	62.1	62.5	63.0	63.3
	Heating	dB(A)	63.1	63.5	64.0	64.3
Sound Power Level	Cooling	dB(A)	83.5	83.8	85.0	85.5
	Heating	dB(A)	85.2	85.5	87.0	87.5
Communication Cable		No. x mm ² (VCTF-SB)	2C x 1.0 - 1.5	2C x 1.0 - 1.5	2C x 1.0 - 1.5	2C x 1.0 - 1.5
Refrigerant	Refrigerant Name		R410A	R410A	R410A	R410A
	Precharged Amount	kg	23.0	26.0	26.0	25.0
		lbs	50.7	57.4	57.4	55.2
	Control		Electronic Expansion Valve	Electronic Expansion Valve	Electronic Expansion Valve	Electronic Expansion Valve
Power Supply		∅, V, Hz	380-415, 3, 50	380-415, 3, 50	380-415, 3, 50	380-415, 3, 50
			400, 3, 60	400, 3, 60	400, 3, 60	400, 3, 60
Number of Maximum Connectable Indoor Units			39(48)	42(52)	45(56)	49(60)

TROPICAL MODEL

HIGH EFFICIENCY

ARUN320LEH5 / ARUN340LEH5 / ARUN360LEH5 / ARUN380LEH5



HP			32	34	36	38
Model Name	Combination Unit		ARUN320LEH5	ARUN340LEH5	ARUN360LEH5	ARUN380LEH5
	Independent Unit		ARUN180LEH5 ARUN140LEH5	ARUN200LEH5 ARUN140LEH5	ARUN200LEH5 ARUN160LEH5	ARUN200LEH5 ARUN180LEH5
Capacity (Rated) ¹⁾	*Cooling - T1 35°C	RT	2	2	2	2
		kW	25.4	27.0	28.6	30.2
		Btu/h	89.6	95.2	100.8	106.4
	**Cooling - T3 46°C	RT	23.9	24.9	25.4	26.8
		kW	84.2	87.8	89.3	94.4
		Btu/h	287,300	299,600	304,800	322,100
	Heating	RT	28.6	30.4	32.1	34.0
		kW	100.6	106.9	113.0	119.7
		Btu/h	343,300	364,800	385,600	408,400
Input (Rated) ¹⁾	*Cooling - T1 35°C	kW	19.82	21.60	22.37	23.22
	**Cooling - T3 46°C	kW	25.69	27.55	28.57	29.68
	Heating	kW	23.03	25.21	25.82	28.86
COP ¹⁾	*Cooling - T1 35°C	kW/kW	4.52	4.41	4.51	4.58
	**Cooling - T3 46°C	kW/kW	3.28	3.19	3.13	3.18
	Heating	kW/kW	4.37	4.24	4.38	4.15
Power Factor	Rated	-	0.93	0.93	0.93	0.93
Casing	Color		Warm Gray / Dawn Gray	Warm Gray / Dawn Gray	Warm Gray / Dawn Gray	Warm Gray / Dawn Gray
Heat Exchanger			Wide Louver Plus	Wide Louver Plus	Wide Louver Plus	Wide Louver Plus
Compressor	Type		Hermetically Sealed Scroll	Hermetically Sealed Scroll	Hermetically Sealed Scroll	Hermetically Sealed Scroll
	Piston Displacement	cm ³ /rev	62.1 x 3	62.1 x 3	(62.1 x 3) + (43.8 x 1)	62.1 x 4
	Number of Revolution	rev/min	3,600 x 3	3,600 x 3	3,600 x 4	3,600 x 4
	Motor Output x Number	W x No.	5,300 x 3	5,300 x 3	(5,300 x 3) + (4,200 x 1)	5,300 x 4
	Starting Method		Direct On Line	Direct On Line	Direct On Line	Direct On Line
	Oil Type		FVC68D(PVE)	FVC68D(PVE)	FVC68D(PVE)	FVC68D(PVE)
Fan	Type		Propeller fan	Propeller fan	Propeller fan	Propeller fan
	Motor Output x Number	W	900 x 4	900 x 4	900 x 4	900 x 4
	Air Flow Rate (High)	m ³ /min	320 x 2	320 x 2	320 x 2	320 x 2
		ft ³ /min	11,301 x 2	11,301 x 2	11,301 x 2	11,301 x 2
	Drive		DC INVERTER	DC INVERTER	DC INVERTER	DC INVERTER
Pipe Connections	Discharge	Side / Top	TOP	TOP	TOP	TOP
	Liquid Pipe	mm(inch)	19.05(3/4)	19.05(3/4)	19.05(3/4)	19.05(3/4)
	Gas Pipe	mm(inch)	34.9(1-3/8)	34.9(1-3/8)	41.3(1-5/8)	41.3(1-5/8)
Dimensions (W x H x D)		mm	(1,240 x 1,690 x 760) x 2	(1,240 x 1,690 x 760) x 2	(1,240 x 1,690 x 760) x 2	(1,240 x 1,690 x 760) x 2
		inch	(48-13/16 x 66-17/32 x 29-29/32) x 2	(48-13/16 x 66-17/32 x 29-29/32) x 2	(48-13/16 x 66-17/32 x 29-29/32) x 2	(48-13/16 x 66-17/32 x 29-29/32) x 2
Net Weight		kg	(281 x 1) + (221 x 1)	(281 x 1) + (221 x 1)	(281 x 1) + (261 x 1)	281 x 2
		lbs	(619 x 1) + (487 x 1)	(619 x 1) + (487 x 1)	(619 x 1) + (575 x 1)	619 x 2
Sound Pressure Level	Cooling	dB(A)	63.5	64.1	64.3	64.5
	Heating	dB(A)	64.5	66.1	66.3	66.4
Sound Power Level	Cooling	dB(A)	86.8	87.5	87.8	88.5
	Heating	dB(A)	88.1	88.8	89.1	89.5
Communication Cable		No. x mm ² (VCTF-SB)	2C x 1.0 - 1.5	2C x 1.0 - 1.5	2C x 1.0 - 1.5	2C x 1.0 - 1.5
Refrigerant	Refrigerant Name		R410A	R410A	R410A	R410A
	Precharged Amount	kg	27.0	27.0	26.0	28.0
		lbs	59.6	59.6	57.4	61.8
	Control		Electronic Expansion Valve	Electronic Expansion Valve	Electronic Expansion Valve	Electronic Expansion Valve
Power Supply		∅, V, Hz	380-415, 3, 50	380-415, 3, 50	380-415, 3, 50	380-415, 3, 50
			400, 3, 60	400, 3, 60	400, 3, 60	400, 3, 60
Number of Maximum Connectable Indoor Units			52(64)	55(64)	58(64)	61(64)

MULTI V 5

TROPICAL MODEL

HIGH EFFICIENCY

ARUN400LEH5 / ARUN420LEH5 / ARUN440LEH5 / ARUN460LEH5



HP		40	42	44	46	
Model Name	Combination Unit	ARUN400LEH5	ARUN420LEH5	ARUN440LEH5	ARUN460LEH5	
	Independent Unit	ARUN200LEH5 ARUN200LEH5	ARUN140LEH5 ARUN140LEH5 ARUN140LEH5	ARUN160LEH5 ARUN140LEH5 ARUN140LEH5	ARUN180LEH5 ARUN140LEH5 ARUN140LEH5	
Capacity (Rated) ¹⁾	*Cooling - T1 35°C	RT	31.8	33.4	35.0	36.6
		kW	112.0	117.6	123.2	128.8
		Btu/h	382,100	401,300	420,400	439,500
	**Cooling - T3 46°C	RT	27.8	33.1	33.5	34.9
		kW	98.0	116.4	117.9	123.0
		Btu/h	334,400	397,200	402,300	419,700
	Heating	RT	35.8	37.4	39.1	41.0
		kW	126.0	131.8	137.8	144.5
		Btu/h	429,900	449,600	470,300	493,200
Input (Rated) ¹⁾	*Cooling - T1 35°C	kW	25.00	27.30	28.07	28.92
	**Cooling - T3 46°C	kW	31.54	35.34	36.36	37.47
	Heating	kW	31.04	29.07	29.68	32.72
COP ¹⁾	*Cooling - T1 35°C	kW/kW	4.48	4.31	4.39	4.45
	**Cooling - T3 46°C	kW/kW	3.11	3.29	3.24	3.28
	Heating	kW/kW	4.06	4.53	4.64	4.42
Power Factor	Rated	-	0.93	0.93	0.93	0.93
Casing	Color	Warm Gray / Dawn Gray	Warm Gray / Dawn Gray	Warm Gray / Dawn Gray	Warm Gray / Dawn Gray	
Heat Exchanger		Wide Louver Plus	Wide Louver Plus	Wide Louver Plus	Wide Louver Plus	
Compressor	Type	Hermetically Sealed Scroll	Hermetically Sealed Scroll	Hermetically Sealed Scroll	Hermetically Sealed Scroll	
	Piston Displacement	cm ³ /rev	62.1 x 4	62.1 x 3	(62.1 x 3) + (43.8 x 1)	62.1 x 4
	Number of Revolution	rev/min	3,600 x 4	3,600 x 3	3,600 x 4	3,600 x 4
	Motor Output x Number	W x No.	5,300 x 4	5,300 x 3	(5,300 x 3) + (4,200 x 1)	5,300 x 4
	Starting Method		Direct On Line	Direct On Line	Direct On Line	Direct On Line
	Oil Type		FVC68D(PVE)	FVC68D(PVE)	FVC68D(PVE)	FVC68D(PVE)
Fan	Type	Propeller fan	Propeller fan	Propeller fan	Propeller fan	
	Motor Output x Number	W	900 x 4	900 x 6	900 x 6	900 x 6
	Air Flow Rate (High)	m ³ /min	320 x 2	320 x 3	320 x 3	320 x 3
		ft ³ /min	11,301 x 2	11,301 x 3	11,301 x 3	11,301 x 3
	Drive		DC INVERTER	DC INVERTER	DC INVERTER	DC INVERTER
Pipe Connections	Discharge	Side / Top	TOP	TOP	TOP	
	Liquid Pipe	mm(inch)	19.05(3/4)	19.05(3/4)	19.05(3/4)	19.05(3/4)
	Gas Pipe	mm(inch)	41.3(1-5/8)	41.3(1-5/8)	41.3(1-5/8)	41.3(1-5/8)
Dimensions (W x H x D)	mm	(1,240 x 1,690 x 760) x 2	(1,240 x 1,690 x 760) x 3	(1,240 x 1,690 x 760) x 3	(1,240 x 1,690 x 760) x 3	
	inch	(48-13/16 x 66-17/32 x 29-29/32) x 2	(48-13/16 x 66-17/32 x 29-29/32) x 3	(48-13/16 x 66-17/32 x 29-29/32) x 3	(48-13/16 x 66-17/32 x 29-29/32) x 3	
Net Weight	kg	281 x 2	221 x 3	(261 x 1) + (221 x 2)	(281 x 1) + (221 x 2)	
	lbs	619 x 2	487 x 3	(575 x 1) + (487 x 2)	(619 x 1) + (487 x 2)	
Sound Pressure Level	Cooling	dB(A)	65.0	64.8	64.9	65.1
	Heating	dB(A)	67.5	65.8	65.9	66.1
Sound Power Level	Cooling	dB(A)	89.0	86.8	87.1	88.0
	Heating	dB(A)	90.0	88.8	89.1	89.5
Communication Cable	No. x mm ² (VCTF-SB)	2C x 1.0 - 1.5	2C x 1.0 - 1.5	2C x 1.0 - 1.5	2C x 1.0 - 1.5	
Refrigerant	Refrigerant Name		R410A	R410A	R410A	
	Precharged Amount	kg	28.0	39.0	38.0	40.0
		lbs	61.8	86.1	83.9	88.3
Control		Electronic Expansion Valve	Electronic Expansion Valve	Electronic Expansion Valve	Electronic Expansion Valve	
Power Supply	Ø, V, Hz		380-415, 3, 50	380-415, 3, 50	380-415, 3, 50	380-415, 3, 50
			400, 3, 60	400, 3, 60	400, 3, 60	400, 3, 60
Number of Maximum Connectable Indoor Units		64	64	64	64	

TROPICAL MODEL

HIGH EFFICIENCY

ARUN480LEH5 / ARUN500LEH5 / ARUN520LEH5 / ARUN540LEH5



HP		48	50	52	54	
Model Name	Combination Unit	ARUN480LEH5	ARUN500LEH5	ARUN520LEH5	ARUN540LEH5	
	Independent Unit	ARUN200LEH5 ARUN140LEH5 ARUN140LEH5	ARUN200LEH5 ARUN160LEH5 ARUN140LEH5	ARUN200LEH5 ARUN180LEH5 ARUN140LEH5	ARUN200LEH5 ARUN200LEH5 ARUN140LEH5	
Capacity (Rated) ¹⁾	*Cooling - T1 35°C	RT	38.2	39.8	41.4	42.9
		kW	134.4	140.0	145.6	151.2
		Btu/h	458,600	477,700	496,800	515,900
	**Cooling - T3 46°C	RT	36.0	36.4	37.8	38.9
		kW	126.6	128.1	133.2	136.8
		Btu/h	432,000	437,100	454,500	466,800
	Heating	RT	42.8	44.6	46.5	48.3
		kW	150.8	156.9	163.6	169.9
		Btu/h	514,700	535,400	558,300	579,800
Input (Rated) ¹⁾	*Cooling - T1 35°C	kW	30.70	31.47	32.32	34.10
	**Cooling - T3 46°C	kW	39.33	40.35	41.46	43.32
	Heating	kW	34.90	35.51	38.55	40.73
COP ¹⁾	*Cooling - T1 35°C	kW/kW	4.38	4.45	4.50	4.43
	**Cooling - T3 46°C	kW/kW	3.22	3.18	3.21	3.16
	Heating	kW/kW	4.32	4.42	4.24	4.17
Power Factor	Rated	-	0.93	0.93	0.93	0.93
Casing	Color	Warm Gray / Dawn Gray	Warm Gray / Dawn Gray	Warm Gray / Dawn Gray	Warm Gray / Dawn Gray	
Heat Exchanger		Wide Louver Plus	Wide Louver Plus	Wide Louver Plus	Wide Louver Plus	
Compressor	Type	Hermetically Sealed Scroll	Hermetically Sealed Scroll	Hermetically Sealed Scroll	Hermetically Sealed Scroll	
	Piston Displacement	cm ³ /rev	62.1 x 4	(62.1 x 4) + (43.8 x 1)	62.1 x 5	62.1 x 5
	Number of Revolution	rev/min	3,600 x 4	3,600 x 5	3,600 x 5	3,600 x 5
	Motor Output x Number	W x No.	5,300 x 4	(5,300 x 4) + (4,200 x 1)	5,300 x 5	5,300 x 5
	Starting Method		Direct On Line	Direct On Line	Direct On Line	Direct On Line
	Oil Type		FVC68D(PVE)	FVC68D(PVE)	FVC68D(PVE)	FVC68D(PVE)
Fan	Type	Propeller fan	Propeller fan	Propeller fan	Propeller fan	
	Motor Output x Number	W	900 x 6	900 x 6	900 x 6	900 x 6
	Air Flow Rate (High)	m ³ /min	320 x 3	320 x 3	320 x 3	320 x 3
		ft ³ /min	11,301 x 3	11,301 x 3	11,301 x 3	11,301 x 3
	Drive		DC INVERTER	DC INVERTER	DC INVERTER	DC INVERTER
Pipe Connections	Discharge	Side / Top	TOP	TOP	TOP	
	Liquid Pipe	mm(inch)	19.05(3/4)	19.05(3/4)	19.05(3/4)	19.05(3/4)
	Gas Pipe	mm(inch)	41.3(1-5/8)	41.3(1-5/8)	41.3(1-5/8)	41.3(1-5/8)
Dimensions (W x H x D)	mm	(1,240 x 1,690 x 760) x 3	(1,240 x 1,690 x 760) x 3	(1,240 x 1,690 x 760) x 3	(1,240 x 1,690 x 760) x 3	
	inch	(48-13/16 x 66-17/32 x 29-29/32) x 3	(48-13/16 x 66-17/32 x 29-29/32) x 3	(48-13/16 x 66-17/32 x 29-29/32) x 3	(48-13/16 x 66-17/32 x 29-29/32) x 3	
Net Weight	kg	(281 x 1) + (221 x 2)	(281 x 1) + (261 x 1) + (221 x 1)	(281 x 2) + (221 x 1)	(281 x 2) + (221 x 1)	
	lbs	(619 x 1) + (487 x 2)	(619 x 1) + (575 x 1) + (487 x 1)	(619 x 2) + (487 x 1)	(619 x 2) + (487 x 1)	
Sound Pressure Level	Cooling	dB(A)	65.5	65.7	65.8	66.2
	Heating	dB(A)	67.3	67.4	67.5	68.4
Sound Power Level	Cooling	dB(A)	88.5	88.8	89.4	89.8
	Heating	dB(A)	90.0	90.3	90.6	91.0
Communication Cable	No. x mm ² (VCTF-SB)	2C x 1.0 - 1.5	2C x 1.0 - 1.5	2C x 1.0 - 1.5	2C x 1.0 - 1.5	
Refrigerant	Refrigerant Name		R410A	R410A	R410A	
	Precharged Amount	kg	40.0	39.0	41.0	41.0
		lbs	88.3	86.1	90.5	90.5
Control		Electronic Expansion Valve	Electronic Expansion Valve	Electronic Expansion Valve	Electronic Expansion Valve	
Power Supply	Ø, V, Hz		380-415, 3, 50	380-415, 3, 50	380-415, 3, 50	380-415, 3, 50
			400, 3, 60	400, 3, 60	400, 3, 60	400, 3, 60
Number of Maximum Connectable Indoor Units		64	64	64	64	

MULTI V 5

TROPICAL MODEL

HIGH EFFICIENCY

ARUN560LEH5 / ARUN580LEH5 / ARUN600LEH5



HP			56	58	60
Model Name	Combination Unit		ARUN560LEH5	ARUN580LEH5	ARUN600LEH5
	Independent Unit		ARUN200LEH5 ARUN200LEH5 ARUN160LEH5	ARUN200LEH5 ARUN200LEH5 ARUN180LEH5	ARUN200LEH5 ARUN200LEH5 ARUN200LEH5
Capacity (Rated) ¹⁾	*Cooling - T1 35°C	RT	44.5	46.1	47.7
		kW	156.8	162.4	168.0
		Btu/h	535,000	554,100	573,200
	**Cooling - T3 46°C	RT	39.3	40.7	41.7
		kW	138.3	143.4	147.0
		Btu/h	471,900	489,300	501,600
	Heating	RT	50.0	51.9	53.7
		kW	176.0	182.7	189.0
		Btu/h	600,500	623,400	644,900
Input (Rated) ¹⁾	*Cooling - T1 35°C	kW	34.87	35.72	37.50
	**Cooling - T3 46°C	kW	44.34	45.45	47.31
	Heating	kW	41.34	44.38	46.56
COP ¹⁾	*Cooling - T1 35°C	kW/kW	4.50	4.55	4.48
	**Cooling - T3 46°C	kW/kW	3.12	3.16	3.11
	Heating	kW/kW	4.26	4.12	4.06
Power Factor	Rated	-	0.93	0.93	0.93
Casing	Color		Warm Gray / Dawn Gray	Warm Gray / Dawn Gray	Warm Gray / Dawn Gray
Heat Exchanger			Wide Louver Plus	Wide Louver Plus	Wide Louver Plus
Compressor	Type		Hermetically Sealed Scroll	Hermetically Sealed Scroll	Hermetically Sealed Scroll
	Piston Displacement	cm ³ /rev	(62.1 x 5) + (43.8 x 1)	62.1 x 6	62.1 x 6
	Number of Revolution	rev/min	3,600 x 6	3,600 x 6	3,600 x 6
	Motor Output x Number	W x No.	(5,300 x 5) + (4,200 x 1)	5,300 x 6	5,300 x 6
	Starting Method		Direct On Line	Direct On Line	Direct On Line
Oil Type		FVC68D(PVE)	FVC68D(PVE)	FVC68D(PVE)	
Fan	Type		Propeller fan	Propeller fan	Propeller fan
	Motor Output x Number	W	900 x 6	900 x 6	900 x 6
	Air Flow Rate (High)	m ³ /min	320 x 3	320 x 3	320 x 3
		ft ³ /min	11,301 x 3	11,301 x 3	11,301 x 3
Pipe Connctions	Liquid Pipe	mm(inch)	19.05(3/4)	19.05(3/4)	19.05(3/4)
	Gas Pipe	mm(inch)	41.3(1-5/8)	41.3(1-5/8)	41.3(1-5/8)
Dimensions (W x H x D)	mm		(1,240 x1,690 x 760) x 3	(1,240 x1,690 x 760) x 3	(1,240 x1,690 x 760) x 3
	inch		(48-13/16 x 66-17/32 x 29-29/32) x 3	(48-13/16 x 66-17/32 x 29-29/32) x 3	(48-13/16 x 66-17/32 x 29-29/32) x 3
Net Weight	kg		(281 x 2) + (261 x 1)	281 x 3	281 x 3
	lbs		(619 x 2) + (575 x 1)	619 x 3	619 x 3
Sound Pressure Level	Cooling	dB(A)	66.3	66.5	66.8
	Heating	dB(A)	68.5	68.6	69.3
Sound Power Level	Cooling	dB(A)	90.0	90.5	90.8
	Heating	dB(A)	91.2	91.5	91.8
Communication Cable	No. x mm ² (VCTF-SB)		2C x 1.0 - 1.5	2C x 1.0 - 1.5	2C x 1.0 - 1.5
Refrigerant	Refrigerant Name		R410A	R410A	R410A
	Precharged Amount	kg	40.0	42.0	42.0
		lbs	88.3	92.7	92.7
Control		Electronic Expansion Valve	Electronic Expansion Valve	Electronic Expansion Valve	
Power Supply	Ø, V, Hz		380-415, 3, 50	380-415, 3, 50	380-415, 3, 50
			400, 3, 60	400, 3, 60	400, 3, 60
Number of Maximum Connectable Indoor Units			64	64	64

NOTE

1. Capacities are based on the following conditions (ISO 15042)

- Cooling Temperature :
*Cooling (T1) : Indoor Temperature 27°C(80.6°F) DB/19°C(66.2°F) WB
Outdoor Temperature 35°C(95°F) DB/24°C(75.2°F)
**Cooling (T3) : Indoor Temperature 29°C(84.2°F) DB/19°C(66.2°F) WB
Outdoor Temperature 46°C(114.8°F) DB/24°C(75.2°F) WB
- Heating Temperature :
Indoor 20°C(68°F) DB / 15°C(59°F) WB
Outdoor 7°C(44.6°F) DB / 6°C(42.8°F) WB
- Piping Length : Interconnected Pipe Length = 7.5m
- Height difference between outdoor unit and indoor unit : 0m

2. The Maximum combination ratio is 130%.

- ### 3. Wiring cable size must comply with the applicable local and national codes.
- And "Electric characteristics" chapter should be considered for electrical work and design. Especially the power cable and circuit breaker should be selected in accordance with that.

4. Sound Level Values are measured at Anechoic chamber. Therefore, these values can be increased owing to ambient conditions during operation.

5. Power factor could vary less than ±1% according to the operating conditions.

6. Due to our policy of innovation some specifications may be changed without notification.

MULTI V 5

TROPICAL MODEL

STANDARD

ARUN080LTH5 / ARUN100LTH5 / ARUN120LTH5 / ARUN140LTH5



HP			8	10	12	14
Model Name	Combination Unit		ARUN080LTH5	ARUN100LTH5	ARUN120LTH5	ARUN140LTH5
	Independent Unit		ARUN080LTH5	ARUN100LTH5	ARUN120LTH5	ARUN140LTH5
Capacity	*Cooling (Rated)	RT	6.4	8.0	9.5	11.1
		kW	22.4	28.0	33.6	39.2
		Btu/h	76,400	95,500	114,600	133,800
	**Cooling (Rated)	RT	5.6	7.1	8.9	10.5
		kW	19.8	25.0	31.2	36.8
		Btu/h	67,600	85,300	106,500	125,600
	Heating (Rated)	RT	7.2	8.6	10.7	12.5
		kW	25.2	30.3	37.8	43.9
		Btu/h	86,000	103,400	129,000	149,900
Input	*Cooling (Rated)	kW	5.00	7.00	8.00	9.30
	**Cooling (Rated)	kW	6.37	8.33	9.54	11.20
	Heating (Rated)	kW	5.80	7.30	8.06	9.69
COP	*Cooling (Rated)	kW	4.48	4.00	4.20	4.22
	**Cooling (Rated)	kW	3.11	3.00	3.27	3.29
	Heating (Rated)	kW	4.34	4.15	4.69	4.53
Power Factor	Rated	-	0.93	0.93	0.93	0.93
Casing	Color		Warm Gray / Dawn Gray	Warm Gray / Dawn Gray	Warm Gray / Dawn Gray	Warm Gray / Dawn Gray
Heat Exchanger			Wide Louver Plus	Wide Louver Plus	Wide Louver Plus	Wide Louver Plus
Compressor	Type		Hermetically Sealed Scroll	Hermetically Sealed Scroll	Hermetically Sealed Scroll	Hermetically Sealed Scroll
	Piston Displacement	cm ³ /rev	62.1	62.1	62.1	62.1
	Number of Revolution	rev/min	3,600	3,600	3,600	3,600
	Motor Output x Number	W x No.	5,300 x 1	5,300 x 1	5,300 x 1	5,300 x 1
	Starting Method		Direct On Line	Direct On Line	Direct On Line	Direct On Line
	Oil Type		FVC68D(PVE)	FVC68D(PVE)	FVC68D(PVE)	FVC68D(PVE)
Fan	Type		Propeller fan	Propeller fan	Propeller fan	Propeller fan
	Motor Output x Number	W	1,200 x 1	1,200 x 1	1,200 x 1	900 x 2
	Air Flow Rate(High)	m ³ /min ft ³ /min	240 x 1 8,476 x 1	240 x 1 8,476 x 1	240 x 1 8,476 x 1	320 x 1 11,301 x 1
	External Static Pressure (Max, Pa)		80	80	80	80
	Drive		DC INVERTER	DC INVERTER	DC INVERTER	DC INVERTER
	Discharge	Side / Top	TOP	TOP	TOP	TOP
Pipe Connctions	Liquid Pipe	mm(inch)	9.52(3/8)	9.52(3/8)	12.7(1/2)	12.7(1/2)
	Gas Pipe	mm(inch)	19.05(3/4)	22.2(7/8)	28.58(1-1/8)	28.58(1-1/8)
Dimensions (W x H x D)	mm		(930 x 1,690 x 760) x 1	(930 x 1,690 x 760) x 1	(930 x 1,690 x 760) x 1	(1,240 x 1,690 x 760)x1
	inch		(36-5/8 x 66-17/32 x 29-29/32) x 1	(36-5/8 x 66-17/32 x 29-29/32) x 1	(36-5/8 x 66-17/32 x 29-29/32) x 1	(48-13/16 x 66-17/32 x 29-29/32) x 1
Net Weight	kg		173 x 1	171 x 1	200 x 1	221 x 1
	lbs		381 x 1	377 x 1	441 x 1	487 x 1
Sound Pressure Level	Cooling	dB(A)	58.0	58.5	59.0	60.0
	Heating	dB(A)	60.0	60.5	60.0	61.0
Sound Power Level	Cooling	dB(A)	78.0	79.0	79.0	82.0
	Heating	dB(A)	80.0	80.0	80.0	84.0
Communication Cable	No. x mm ² (VCTF-SB)		2C x 1.0 - 1.5	2C x 1.0 - 1.5	2C x 1.0 - 1.5	2C x 1.0 - 1.5
Refrigerant	Refrigerant name		R410A	R410A	R410A	R410A
	Precharged Amount in factory	kg lbs	4.7 10.4	4.7 10.4	10.0 22.0	13.0 28.7
	Control		Electronic Expansion Valve	Electronic Expansion Valve	Electronic Expansion Valve	Electronic Expansion Valve
Power Supply	∅, V, Hz		380-415, 3, 50	380-415, 3, 50	380-415, 3, 50	380-415, 3, 50
Number of Maximum Connectable Indoor Units			400, 3, 60	400, 3, 60	400, 3, 60	400, 3, 60
			13	16	20	23

TROPICAL MODEL

STANDARD

ARUN160LTH5 / ARUN180LTH5 / ARUN200LTH5 / ARUN220LTH5



HP			16	18	20	22
Model Name	Combination Unit		ARUN160LTH5	ARUN180LTH5	ARUN200LTH5	ARUN220LTH5
	Independent Unit		ARUN160LTH5	ARUN180LTH5	ARUN200LTH5	ARUN220LTH5
Capacity	*Cooling (Rated)	RT	12.7	14.3	15.9	17.5
		kW	44.8	50.4	56.0	61.6
		Btu/h	152,900	172,000	191,100	210,200
	**Cooling (Rated)	RT	11.4	12.4	13.6	14.1
		kW	40.3	43.6	48.0	49.6
		Btu/h	137,500	148,800	163,800	169,100
	Heating (Rated)	RT	14.2	16.1	17.9	19.7
		kW	50.0	56.7	63.0	69.3
		Btu/h	170,600	193,500	215,000	236,500
Input	*Cooling (Rated)	kW	10.80	11.20	13.00	14.84
	**Cooling (Rated)	kW	13.15	14.39	15.77	16.72
	Heating (Rated)	kW	11.36	11.98	15.52	17.54
COP	*Cooling (Rated)	kW	4.15	4.50	4.31	4.15
	**Cooling (Rated)	kW	3.06	3.03	3.04	2.96
	Heating (Rated)	kW	4.40	4.73	4.06	3.95
Power Factor	Rated	-	0.93	0.93	0.93	0.93
Casing	Color		Warm Gray / Dawn Gray	Warm Gray / Dawn Gray	Warm Gray / Dawn Gray	Warm Gray / Dawn Gray
Heat Exchanger			Wide Louver Plus	Wide Louver Plus	Wide Louver Plus	Wide Louver Plus
Compressor	Type		Hermetically Sealed Scroll	Hermetically Sealed Scroll	Hermetically Sealed Scroll	Hermetically Sealed Scroll
	Piston Displacement	cm ³ /rev	62.1	62.1 x 1 + 43.8 x 1	62.1 x 2	62.1 x 2
	Number of Revolution	rev/min	3,600	3,600 x 2	3,600 x 2	3,600 x 2
	Motor Output x Number	W x No.	5,300 x 1	5,300 x 1 + 4,200 x 1	5,300 x 2	5,300 x 2
	Starting Method		Direct On Line	Direct On Line	Direct On Line	Direct On Line
	Oil Type		FVC68D(PVE)	FVC68D(PVE)	FVC68D(PVE)	FVC68D(PVE)
Fan	Type		Propeller fan	Propeller fan	Propeller fan	Propeller fan
	Motor Output x Number	W	900 x 2	900 x 2	900 x 2	900 x 2
	Air Flow Rate(High)	m ³ /min ft ³ /min	320 x 1 11,301 x 1	320 x 1 11,301 x 1	320 x 1 11,301 x 1	320 x 1 11,301 x 1
	External Static Pressure (Max, Pa)		80	80	80	80
	Drive		DC INVERTER	DC INVERTER	DC INVERTER	DC INVERTER
	Discharge	Side / Top	TOP	TOP	TOP	TOP
Pipe Connctions	Liquid Pipe	mm(inch)	12.7(1/2)	15.88(5/8)	15.88(5/8)	15.88(5/8)
	Gas Pipe	mm(inch)	28.58(1-1/8)	28.58(1-1/8)	28.58(1-1/8)	28.58(1-1/8)
Dimensions (W x H x D)	mm		(1,240 x 1,690 x 760)x1	(1,240 x 1,690 x 760)x1	(1,240 x 1,690 x 760)x1	(1,240 x 1,690 x 760)x1
	inch		(48-13/16 x 66-17/32 x 29-29/32) x 1	(48-13/16 x 66-17/32 x 29-29/32) x 1	(48-13/16 x 66-17/32 x 29-29/32) x 1	(48-13/16 x 66-17/32 x 29-29/32) x 1
Net Weight	kg		221 x 1	261 x 1	281 x 1	281 x 1
	lbs		487 x 1	575 x 1	619 x 1	619 x 1
Sound Pressure Level	Cooling	dB(A)	60.5	61.0	62.0	64.5
	Heating	dB(A)	61.5	62.0	64.5	65.5
Sound Power Level	Cooling	dB(A)	83.0	85.0	86.0	86.0
	Heating	dB(A)	85.0	86.0	87.0	88.0
Communication Cable	No. x mm ² (VCTF-SB)		2C x 1.0 - 1.5	2C x 1.0 - 1.5	2C x 1.0 - 1.5	2C x 1.0 - 1.5
Refrigerant	Refrigerant name		R410A	R410A	R410A	R410A
	Precharged Amount in factory	kg lbs	13.0 28.7	13.0 28.7	30.9 68.3	30.9 68.3
	Control		Electronic Expansion Valve	Electronic Expansion Valve	Electronic Expansion Valve	Electronic Expansion Valve
Power Supply	∅, V, Hz		380-415, 3, 50	380-415, 3, 50	380-415, 3, 50	380-415, 3, 50
Number of Maximum Connectable Indoor Units			400, 3, 60	400, 3, 60	400, 3, 60	400, 3, 60
			26	29	32	35

MULTI V 5

TROPICAL MODEL

STANDARD

ARUN240LTH5 / ARUN260LTH5 / ARUN280LTH5 / ARUN300LTH5



HP			24	26	28	30
Model Name	Combination Unit		ARUN240LTH5	ARUN260LTH5	ARUN280LTH5	ARUN300LTH5
	Independent Unit		ARUN120LTH5 ARUN120LTH5	ARUN140LTH5 ARUN120LTH5	ARUN160LTH5 ARUN120LTH5	ARUN160LTH5 ARUN140LTH5
Capacity	*Cooling (Rated)	RT	19.1	20.7	22.3	23.9
		kW	67.2	72.8	78.4	84.0
		Btu/h	229,300	248,400	267,500	286,600
	**Cooling (Rated)	RT	17.7	19.3	20.3	21.9
		kW	62.4	68.0	71.5	77.1
		Btu/h	212,900	232,000	244,000	263,100
Heating (Rated)	RT	21.5	23.2	24.9	26.7	
	kW	75.6	81.7	87.8	93.9	
	Btu/h	257,900	278,800	299,600	320,500	
Input	*Cooling (Rated)	kW	16.00	17.30	18.80	20.10
	**Cooling (Rated)	kW	19.08	20.74	22.69	24.35
	Heating (Rated)	kW	16.12	17.75	19.42	21.05
COP	*Cooling (Rated)	kW	4.20	4.21	4.17	4.18
	**Cooling (Rated)	kW	3.27	3.28	3.15	3.17
	Heating (Rated)	kW	4.69	4.60	4.52	4.46
Power Factor	Rated	-	0.93	0.93	0.93	0.93
Casing	Color		Warm Gray / Dawn Gray	Warm Gray / Dawn Gray	Warm Gray / Dawn Gray	Warm Gray / Dawn Gray
Heat Exchanger			Wide Louver Plus	Wide Louver Plus	Wide Louver Plus	Wide Louver Plus
Compressor	Type		Hermetically Sealed Scroll	Hermetically Sealed Scroll	Hermetically Sealed Scroll	Hermetically Sealed Scroll
	Piston Displacement	cm ³ /rev	62.1 x 2	62.1 x 2	62.1 x 2	62.1 x 2
	Number of Revolution	rev/min	3,600 x 2	3,600 x 2	3,600 x 2	3,600 x 2
	Motor Output x Number	W x No.	5,300 x 2	5,300 x 2	5,300 x 2	5,300 x 2
	Starting Method		Direct On Line	Direct On Line	Direct On Line	Direct On Line
	Oil Type		FVC68D(PVE)	FVC68D(PVE)	FVC68D(PVE)	FVC68D(PVE)
Fan	Type		Propeller fan	Propeller fan	Propeller fan	Propeller fan
	Motor Output x Number	W	1,200 x 2	(900 x 2) + (1,200 x 1)	(900 x 2) + (1,200 x 1)	900 x 4
	Air Flow Rate(High)	m ³ /min	240 x 2	(320 x 1) + (240 x 1)	(320 x 1) + (240 x 1)	320 x 2
		ft ³ /min	8,476 x 2	(11,301 x 1) + (8,476 x 1)	(11,301 x 1) + (8,476 x 1)	11,301 x 2
	External Static Pressure (Max, Pa)		80	80	80	80
	Drive		DC INVERTER	DC INVERTER	DC INVERTER	DC INVERTER
Pipe Connections	Liquid Pipe	mm(inch)	15.88(5/8)	19.05(3/4)	19.05(3/4)	19.05(3/4)
	Gas Pipe	mm(inch)	34.9(1-3/8)	34.9(1-3/8)	34.9(1-3/8)	34.9(1-3/8)
Dimensions (W x H x D)	mm		(930 x 1,690 x 760) x 2	(1,240 x 1,690 x 760) x 1 + (930 x 1,690 x 760) x 1	(1,240 x 1,690 x 760) x 1 + (930 x 1,690 x 760) x 1	(1,240 x 1,690 x 760) x 2
	inch		(36-5/8 x 66-17/32 x 29-29/32) x 2	(48-13/16 x 66-17/32 x 29-29/32) x 1 + (36-5/8 x 66-17/32 x 29-29/32) x 1	(48-13/16 x 66-17/32 x 29-29/32) x 1 + (36-5/8 x 66-17/32 x 29-29/32) x 1	(48-13/16 x 66-17/32 x 29-29/32) x 2
Net Weight	kg		200 x 2	(221 x 1) + (200 x 1)	(221 x 1) + (200 x 1)	221 x 2
	lbs		441 x 2	(487 x 1) + (441 x 1)	(487 x 1) + (441 x 1)	487 x 2
Sound Pressure Level	Cooling	dB(A)	62.0	62.5	62.8	63.3
	Heating	dB(A)	63.0	63.5	63.8	64.3
Sound Power Level	Cooling	dB(A)	82.0	83.8	84.5	85.5
	Heating	dB(A)	83.0	85.5	86.2	87.5
Communication Cable	No. x mm ² (VCTF-SB)		2C x 1.0 - 1.5	2C x 1.0 - 1.5	2C x 1.0 - 1.5	2C x 1.0 - 1.5
Refrigerant	Refrigerant name		R410A	R410A	R410A	R410A
	Precharged Amount in factory	kg	10.0 + 10.0	13.0 + 10.0	13.0 + 10.0	13.0 + 13.0
		lbs	22.0 + 22.0	28.7 + 22.0	28.7 + 22.0	28.7 + 28.7
	Control		Electronic Expansion Valve	Electronic Expansion Valve	Electronic Expansion Valve	Electronic Expansion Valve
Power Supply	∅, V, Hz		380-415, 3, 50	380-415, 3, 50	380-415, 3, 50	380-415, 3, 50
Number of Maximum Connectable Indoor Units			39	42	45	49

TROPICAL MODEL

STANDARD

ARUN320LTH5 / ARUN340LTH5 / ARUN360LTH5



HP			32	34	36
Model Name	Combination Unit		ARUN320LTH5	ARUN340LTH5	ARUN360LTH5
	Independent Unit		ARUN160LTH5 ARUN160LTH5	ARUN180LTH5 ARUN160LTH5	ARUN200LTH5 ARUN160LTH5
Capacity	*Cooling (Rated)	RT	25.4	27.0	28.6
		kW	89.6	95.2	100.8
		Btu/h	305,700	324,800	343,900
	**Cooling (Rated)	RT	22.9	23.8	25.1
		kW	80.6	83.9	88.3
		Btu/h	275,000	286,300	301,300
Heating (Rated)	RT	28.4	30.3	32.1	
	kW	100.0	106.7	113.0	
	Btu/h	341,200	364,100	385,600	
Input	*Cooling (Rated)	kW	21.60	22.00	23.80
	**Cooling (Rated)	kW	26.30	27.54	28.92
	Heating (Rated)	kW	22.72	23.34	26.88
COP	*Cooling (Rated)	kW	4.15	4.33	4.24
	**Cooling (Rated)	kW	3.06	3.05	3.05
	Heating (Rated)	kW	4.40	4.57	4.20
Power Factor	Rated	-	0.93	0.93	0.93
Casing	Color		Warm Gray / Dawn Gray	Warm Gray / Dawn Gray	Warm Gray / Dawn Gray
Heat Exchanger			Wide Louver Plus	Wide Louver Plus	Wide Louver Plus
Compressor	Type		Hermetically Sealed Scroll	Hermetically Sealed Scroll	Hermetically Sealed Scroll
	Piston Displacement	cm ³ /rev	62.1 x 2	(62.1 x 2) + (43.8 x 1)	62.1 x 3
	Number of Revolution	rev/min	3,600 x 2	3,600 x 3	3,600 x 3
	Motor Output x Number	W x No.	5,300 x 2	(5,300 x 2) + (4,200 x 1)	5,300 x 3
	Starting Method		Direct On Line	Direct On Line	Direct On Line
	Oil Type		FVC68D(PVE)	FVC68D(PVE)	FVC68D(PVE)
Fan	Type		Propeller fan	Propeller fan	Propeller fan
	Motor Output x Number	W	900 x 4	900 x 4	900 x 4
	Air Flow Rate(High)	m ³ /min	320 x 2	320 x 2	320 x 2
		ft ³ /min	11,301 x 2	11,301 x 2	11,301 x 2
	External Static Pressure (Max, Pa)		80	80	80
	Drive		DC INVERTER	DC INVERTER	DC INVERTER
Pipe Connections	Liquid Pipe	mm(inch)	19.05(3/4)	19.05(3/4)	19.05(3/4)
	Gas Pipe	mm(inch)	34.9(1-3/8)	34.9(1-3/8)	41.3(1-5/8)
Dimensions (W x H x D)	mm		(1,240 x 1,690 x 760) x 2	(1,240 x 1,690 x 760) x 2	(1,240 x 1,690 x 760) x 2
	inch		(48-13/16 x 66-17/32 x 29-29/32) x 2	(48-13/16 x 66-17/32 x 29-29/32) x 2	(48-13/16 x 66-17/32 x 29-29/32) x 2
Net Weight	kg		221 x 2	(261 x 1) + (221 x 1)	(281 x 1) + (221 x 1)
	lbs		487 x 2	(575 x 1) + (487 x 1)	(619 x 1) + (487 x 1)
Sound Pressure Level	Cooling	dB(A)	63.5	63.8	64.3
	Heating	dB(A)	64.5	64.8	66.3
Sound Power Level	Cooling	dB(A)	86.0	87.1	87.8
	Heating	dB(A)	88.0	88.5	89.1
Communication Cable	No. x mm ² (VCTF-SB)		2C x 1.0 - 1.5	2C x 1.0 - 1.5	2C x 1.0 - 1.5
Refrigerant	Refrigerant name		R410A	R410A	R410A
	Precharged Amount in factory	kg	13.0 + 13.0	13.0 + 13.0	14.0 + 13.0
		lbs	28.7 + 28.7	28.7 + 28.7	30.9 + 28.7
	Control		Electronic Expansion Valve	Electronic Expansion Valve	Electronic Expansion Valve
Power Supply	∅, V, Hz		380-415, 3, 50	380-415, 3, 50	380-415, 3, 50
Number of Maximum Connectable Indoor Units			52	55	58

MULTI V 5

TROPICAL MODEL

STANDARD

ARUN380LTH5 / ARUN400LTH5 / ARUN420LTH5



HP			38	40	42
Model Name	Combination Unit		ARUN380LTH5	ARUN400LTH5	ARUN420LTH5
	Independent Unit		ARUN220LTH5 ARUN160LTH5	ARUN200LTH5 ARUN200LTH5	ARUN220LTH5 ARUN200LTH5
Capacity	*Cooling (Rated)	RT	30.2	31.8	33.4
		kW	106.4	112.0	117.6
		Btu/h	363,000	382,100	401,300
		RT	25.5	27.3	27.7
	**Cooling (Rated)	kW	89.9	96.0	97.6
		Btu/h	306,600	327,600	332,900
		RT	33.9	35.8	37.6
		kW	119.3	126.0	132.3
Heating (Rated)	Btu/h	407,100	429,900	451,400	
	kW	25.64	26.00	27.84	
Input	*Cooling (Rated)		29.87	31.54	32.49
	Heating (Rated)		28.90	31.04	33.06
	kW		4.15	4.31	4.22
COP	*Cooling (Rated)		3.01	3.04	3.00
	**Cooling (Rated)		4.13	4.06	4.00
	Heating (Rated)		0.93	0.93	0.93
Power Factor	Rated		-	-	-
Casing	Color		Warm Gray / Dawn Gray	Warm Gray / Dawn Gray	Warm Gray / Dawn Gray
Heat Exchanger			Wide Louver Plus	Wide Louver Plus	Wide Louver Plus
Compressor	Type		Hermetically Sealed Scroll	Hermetically Sealed Scroll	Hermetically Sealed Scroll
	Piston Displacement	cm ³ /rev	62.1 x 3	62.1 x 4	62.1 x 4
	Number of Revolution	rev/min	3,600 x 3	3,600 x 4	3,600 x 4
	Motor Output x Number	W x No.	5,300 x 3	5,300 x 4	5,300 x 4
	Starting Method		Direct On Line	Direct On Line	Direct On Line
	Oil Type		FVC68D(PVE)	FVC68D(PVE)	FVC68D(PVE)
	Type		Propeller fan	Propeller fan	Propeller fan
Fan	Motor Output x Number	W	900 x 4	900 x 4	900 x 4
	Air Flow Rate(High)	m ³ /min	320 x 2	320 x 2	320 x 2
		ft ³ /min	11,301 x 2	11,301 x 2	11,301 x 2
	External Static Pressure (Max, Pa)		80	80	80
	Drive		DC INVERTER	DC INVERTER	DC INVERTER
	Discharge	Side / Top	TOP	TOP	TOP
Pipe Connections	Liquid Pipe	mm(inch)	19.05(3/4)	19.05(3/4)	19.05(3/4)
	Gas Pipe	mm(inch)	41.3(1-5/8)	41.3(1-5/8)	41.3(1-5/8)
Dimensions (W x H x D)	mm		(1,240 x1,690 x 760) x 2	(1,240 x1,690 x 760) x 2	(1,240 x1,690 x 760) x 2
	inch		(48-13/16 x 66-17/32 x 29-29/32) x 2	(48-13/16 x 66-17/32 x 29-29/32) x 2	(48-13/16 x 66-17/32 x 29-29/32) x 2
Net Weight	kg		(281 x 1) + (221 x 1)	281 x 2	281 x 2
	lbs		(619 x 1) + (487 x 1)	619 x 2	619 x 2
Sound Pressure Level	Cooling	dB(A)	66.0	65.0	66.4
	Heating	dB(A)	67.0	67.5	68.0
Sound Power Level	Cooling	dB(A)	87.8	89.0	89.0
	Heating	dB(A)	89.8	90.0	90.5
Communication Cable	No. xmm ² (VCTF-SB)		2C x 1.0 - 1.5	2C x 1.0 - 1.5	2C x 1.0 - 1.5
Refrigerant	Refrigerant name		R410A	R410A	R410A
	Precharged Amount in factory	kg	14.0 + 13.0	14.0 + 14.0	14.0 + 14.0
		lbs	30.9 + 28.7	30.9 + 30.9	30.9 + 30.9
	Control		Electronic Expansion Valve	Electronic Expansion Valve	Electronic Expansion Valve
Power Supply	Ø, V, Hz		380-415, 3, 50	380-415, 3, 50	380-415, 3, 50
Number of Maximum Connectable Indoor Units			400, 3, 60	400, 3, 60	400, 3, 60

TROPICAL MODEL

STANDARD

ARUN440LTH5 / ARUN460LTH5 / ARUN480LTH5



HP			44	46	48
Model Name	Combination Unit		ARUN440LTH5	ARUN460LTH5	ARUN480LTH5
	Independent Unit		ARUN220LTH5 ARUN220LTH5	ARUN160LTH5 ARUN160LTH5 ARUN140LTH5	ARUN160LTH5 ARUN160LTH5 ARUN160LTH5
Capacity	*Cooling (Rated)	RT	2	3	3
		kW	35.0	36.6	38.2
		Btu/h	123.2	128.8	134.4
		RT	420,400	439,500	458,600
	**Cooling (Rated)	kW	28.2	33.3	34.3
		Btu/h	99.2	117.4	120.9
		RT	338,200	400,600	412,500
		kW	39.4	40.9	42.6
Heating (Rated)	kW	138.6	143.9	150.0	
	Btu/h	472,900	491,000	511,800	
Input	*Cooling (Rated)		29.68	30.90	32.40
	**Cooling (Rated)		33.44	37.50	39.45
	Heating (Rated)		35.08	32.41	34.08
COP	*Cooling (Rated)		4.15	4.17	4.15
	**Cooling (Rated)		2.97	3.13	3.06
	Heating (Rated)		3.95	4.44	4.40
Power Factor	Rated		-	-	-
Casing	Color		Warm Gray / Dawn Gray	Warm Gray / Dawn Gray	Warm Gray / Dawn Gray
Heat Exchanger			Wide Louver Plus	Wide Louver Plus	Wide Louver Plus
Compressor	Type		Hermetically Sealed Scroll	Hermetically Sealed Scroll	Hermetically Sealed Scroll
	Piston Displacement	cm ³ /rev	62.1 x 4	62.1 x 3	62.1 x 3
	Number of Revolution	rev/min	3,600 x 4	3,600 x 3	3,600 x 3
	Motor Output x Number	W x No.	5,300 x 4	5,300 x 3	5,300 x 3
	Starting Method		Direct On Line	Direct On Line	Direct On Line
	Oil Type		FVC68D(PVE)	FVC68D(PVE)	FVC68D(PVE)
	Type		Propeller fan	Propeller fan	Propeller fan
Fan	Motor Output x Number	W	900 x 4	900 x 6	900 x 6
	Air Flow Rate(High)	m ³ /min	320 x 2	320 x 3	320 x 3
		ft ³ /min	1,1301 x 2	11,301 x 3	11,301 x 3
	External Static Pressure (Max, Pa)		80	80	80
	Drive		DC INVERTER	DC INVERTER	DC INVERTER
	Discharge	Side / Top	TOP	TOP	TOP
Pipe Connections	Liquid Pipe	mm(inch)	19.05(3/4)	19.05(3/4)	19.05(3/4)
	Gas Pipe	mm(inch)	41.3(1-5/8)	41.3(1-5/8)	41.3(1-5/8)
Dimensions (W x H x D)	mm		(1,240 x1,690 x 760) x 2	(1,240 x1,690 x 760) x 3	(1,240 x1,690 x 760) x 3
	inch		(48-13/16 x 66-17/32 x 29-29/32) x 2	(48-13/16 x 66-17/32 x 29-29/32) x 3	(48-13/16 x 66-17/32 x 29-29/32) x 3
Net Weight	kg		281 x 2	221 x 3	221 x 3
	lbs		619 x 2	487 x 3	487 x 3
Sound Pressure Level	Cooling	dB(A)	67.5	65.1	65.3
	Heating	dB(A)	68.5	66.1	66.3
Sound Power Level	Cooling	dB(A)	89.0	87.5	87.8
	Heating	dB(A)	91.0	89.5	89.8
Communication Cable	No. xmm ² (VCTF-SB)		2C x 1.0 - 1.5	2C x 1.0 - 1.5	2C x 1.0 - 1.5
Refrigerant	Refrigerant name		R410A	R410A	R410A
	Precharged Amount in factory	kg	14.0 + 14.0	13.0 + 13.0 + 13.0	13.0 + 13.0 + 13.0
		lbs	30.9 + 30.9	28.7 + 28.7 + 28.7	28.7 + 28.7 + 28.7
	Control		Electronic Expansion Valve	Electronic Expansion Valve	Electronic Expansion Valve
Power Supply	Ø, V, Hz		380-415, 3, 50	380-415, 3, 50	380-415, 3, 50
Number of Maximum Connectable Indoor Units			400, 3, 60	400, 3, 60	400, 3, 60

MULTI V 5

TROPICAL MODEL

STANDARD

ARUN500LTH5 / ARUN520LTH5 / ARUN540LTH5



HP			50	52	54
Model Name	Combination Unit		ARUN500LTH5	ARUN520LTH5	ARUN540LTH5
	Independent Unit		ARUN180LTH5 ARUN160LTH5 ARUN160LTH5	ARUN200LTH5 ARUN160LTH5 ARUN160LTH5	ARUN220LTH5 ARUN160LTH5 ARUN160LTH5
Capacity	*Cooling (Rated)	RT	39.8	41.4	42.9
		kW	140.0	145.6	151.2
		Btu/h	477,700	496,800	515,900
	**Cooling (Rated)	RT	35.3	36.5	37.0
		kW	124.2	128.6	130.2
		Btu/h	423,800	438,800	444,200
	Heating (Rated)	RT	44.5	46.3	48.1
		kW	156.7	163.0	169.3
		Btu/h	534,700	556,200	577,700
	Input	*Cooling (Rated)	kW	32.80	34.60
**Cooling (Rated)		kW	40.69	42.07	43.02
Heating (Rated)		kW	34.70	38.24	40.26
COP	*Cooling (Rated)	kW	4.27	4.21	4.15
	**Cooling (Rated)	kW	3.05	3.06	3.03
	Heating (Rated)	kW	4.52	4.26	4.21
Power Factor	Rated	-	0.93	0.93	0.93
Casing	Color		Warm Gray / Dawn Gray	Warm Gray / Dawn Gray	Warm Gray / Dawn Gray
Heat Exchanger			Wide Louver Plus	Wide Louver Plus	Wide Louver Plus
Compressor	Type		Hermetically Sealed Scroll	Hermetically Sealed Scroll	Hermetically Sealed Scroll
	Piston Displacement	cm ³ /rev	(62.1 x 3) + (43.8 x 1)	62.1 x 4	62.1 x 4
	Number of Revolution	rev/min	3,600 x 4	3,600 x 4	3,600 x 4
	Motor Output x Number	W x No.	(5,300 x 3) + (4,200 x 1)	5,300 x 4	5,300 x 4
	Starting Method		Direct On Line	Direct On Line	Direct On Line
	Oil Type		FVC68D(PVE)	FVC68D(PVE)	FVC68D(PVE)
Fan	Type		Propeller fan	Propeller fan	Propeller fan
	Motor Output x Number	W	900 x 6	900 x 6	900 x 6
	Air Flow Rate(High)	m ³ /min	320 x 3	320 x 3	320 x 3
		ft ³ /min	11,301 x 3	11,301 x 3	11,301 x 3
	External Static Pressure (Max, Pa)		80	80	80
	Drive		DC INVERTER	DC INVERTER	DC INVERTER
Discharge	Side / Top	TOP	TOP	TOP	
Pipe Connctions	Liquid Pipe	mm(inch)	19.05(3/4)	19.05(3/4)	19.05(3/4)
	Gas Pipe	mm(inch)	41.3(1-5/8)	41.3(1-5/8)	41.3(1-5/8)
Dimensions (W x H x D)	mm		(1,240 x1,690 x 760) x 3	(1,240 x1,690 x 760) x 3	(1,240 x1,690 x 760) x 3
	inch		(48-13/16 x 66-17/32 x 29-29/32) x 3	(48-13/16 x 66-17/32 x 29-29/32) x 3	(48-13/16 x 66-17/32 x 29-29/32) x 3
Net Weight	kg		(261 x 1) + (221 x 2)	(281 x 1) + (221 x 2)	(281 x 1) + (221 x 2)
	lbs		(575 x 1) + (487 x 2)	(619 x 1) + (487 x 2)	(619 x 1) + (487 x 2)
Sound Pressure Level	Cooling	dB(A)	65.4	65.8	67.0
	Heating	dB(A)	66.4	67.5	68.0
Sound Power Level	Cooling	dB(A)	88.5	89.0	89.0
	Heating	dB(A)	90.1	90.5	91.0
Communication Cable	No.xmm ² (VCTF-SB)		2C x 1.0 ~ 1.5	2C x 1.0 ~ 1.5	2C x 1.0 ~ 1.5
Refrigerant	Refrigerant name		R410A	R410A	R410A
	Precharged Amount in factory	kg	13.0 + 13.0 + 13.0	14.0 + 13.0 + 13.0	14.0 + 13.0 + 13.0
		lbs	28.7 + 28.7 + 28.7	30.9 + 28.7 + 28.7	30.9 + 28.7 + 28.7
Control		Electronic Expansion Valve	Electronic Expansion Valve	Electronic Expansion Valve	
Power Supply	Ø, V, Hz		380-415, 3, 50	380-415, 3, 50	380-415, 3, 50
			400, 3, 60	400, 3, 60	400, 3, 60
Number of Maximum Connectable Indoor Units			64	64	64

TROPICAL MODEL

STANDARD

ARUN560LTH5 / ARUN580LTH5 / ARUN600LTH5



HP			56	58	60
Model Name	Combination Unit		ARUN560LTH5	ARUN580LTH5	ARUN600LTH5
	Independent Unit		ARUN200LTH5 ARUN200LTH5 ARUN160LTH5	ARUN220LTH5 ARUN200LTH5 ARUN160LTH5	ARUN220LTH5 ARUN220LTH5 ARUN160LTH5
Capacity	*Cooling (Rated)	RT	44.5	46.1	47.7
		kW	156.8	162.4	168.0
		Btu/h	535,000	554,100	573,200
	**Cooling (Rated)	RT	38.7	39.2	39.6
		kW	136.3	137.9	139.5
		Btu/h	465,100	470,500	476,000
	Heating (Rated)	RT	50.0	51.8	53.6
		kW	176.0	182.3	188.6
		Btu/h	600,500	622,000	643,500
	Input	*Cooling (Rated)	kW	36.80	38.64
**Cooling (Rated)		kW	44.69	45.64	46.59
Heating (Rated)		kW	42.40	44.42	46.44
COP	*Cooling (Rated)	kW	4.26	4.20	4.15
	**Cooling (Rated)	kW	3.05	3.02	2.99
	Heating (Rated)	kW	4.15	4.10	4.06
Power Factor	Rated	-	0.93	0.93	0.93
Casing	Color		Warm Gray / Dawn Gray	Warm Gray / Dawn Gray	Warm Gray / Dawn Gray
Heat Exchanger			Wide Louver Plus	Wide Louver Plus	Wide Louver Plus
Compressor	Type		Hermetically Sealed Scroll	Hermetically Sealed Scroll	Hermetically Sealed Scroll
	Piston Displacement	cm ³ /rev	62.1 x 5	62.1 x 5	62.1 x 5
	Number of Revolution	rev/min	3,600 x 5	3,600 x 5	3,600 x 5
	Motor Output x Number	W x No.	5,300 x 5	5,300 x 5	5,300 x 5
	Starting Method		Direct On Line	Direct On Line	Direct On Line
	Oil Type		FVC68D(PVE)	FVC68D(PVE)	FVC68D(PVE)
Fan	Type		Propeller fan	Propeller fan	Propeller fan
	Motor Output x Number	W	900 x 6	900 x 6	900 x 6
	Air Flow Rate(High)	m ³ /min	320 x 3	320 x 3	320 x 3
		ft ³ /min	11,301 x 3	11,301 x 3	11,301 x 3
	External Static Pressure (Max, Pa)		80	80	80
	Drive		DC INVERTER	DC INVERTER	DC INVERTER
Discharge	Side / Top	TOP	TOP	TOP	
Pipe Connctions	Liquid Pipe	mm(inch)	19.05(3/4)	19.05(3/4)	19.05(3/4)
	Gas Pipe	mm(inch)	41.3(1-5/8)	41.3(1-5/8)	41.3(1-5/8)
Dimensions (W x H x D)	mm		(1,240 x1,690 x 760) x 3	(1,240 x1,690 x 760) x 3	(1,240 x 1,690 x 760) x 3
	inch		(48-13/16 x 66-17/32 x 29-29/32) x 3	(48-13/16 x 66-17/32 x 29-29/32) x 3	(48-13/16 x 66-17/32 x 29-29/32) x 3
Net Weight	kg		(281 x 2) + (221 x 1)	(281 x 2) + (221 x 1)	(281 x 2) + (221 x 1)
	lbs		(619 x 2) + (487 x 1)	(619 x 2) + (487 x 1)	(619 x 2) + (487 x 1)
Sound Pressure Level	Cooling	dB(A)	66.3	67.4	68.3
	Heating	dB(A)	68.5	68.9	69.3
Sound Power Level	Cooling	dB(A)	90.0	90.0	90.0
	Heating	dB(A)	91.2	91.6	92.0
Communication Cable	No.xmm ² (VCTF-SB)		2C x 1.0 ~ 1.5	2C x 1.0 ~ 1.5	2C x 1.0 ~ 1.5
Refrigerant	Refrigerant name		R410A	R410A	R410A
	Precharged Amount in factory	kg	14.0 + 14.0 + 13.0	14.0 + 14.0 + 13.0	14.0 + 14.0 + 13.0
		lbs	30.9 + 30.9 + 28.7	30.9 + 30.9 + 28.7	30.9 + 30.9 + 28.7
Control		Electronic Expansion Valve	Electronic Expansion Valve	Electronic Expansion Valve	
Power Supply	Ø, V, Hz		380-415, 3, 50	380-415, 3, 50	380-415, 3, 50
			400, 3, 60	400, 3, 60	400, 3, 60
Number of Maximum Connectable Indoor Units			64	64	64

MULTI V 5

TROPICAL MODEL

STANDARD

ARUN620LTH5 / ARUN640LTH5 / ARUN660LTH5



HP			62	64	66
Model Name	Combination Unit		ARUN620LTH5	ARUN640LTH5	ARUN660LTH5
	Independent Unit		ARUN220LTH5 ARUN200LTH5 ARUN200LTH5	ARUN220LTH5 ARUN200LTH5 ARUN200LTH5	ARUN220LTH5 ARUN200LTH5 ARUN200LTH5
Capacity	*Cooling (Rated)	RT	49.3	50.9	52.5
		kW	173.6	179.2	184.8
		Btu/h	592,300	611,400	630,500
	**Cooling (Rated)	RT	41.4	41.8	42.3
		kW	145.6	147.2	148.8
		Btu/h	496,800	502,200	507,700
	Heating (Rated)	RT	55.5	57.3	59.0
		kW	195.3	201.6	207.9
		Btu/h	666,400	687,900	709,400
	Input	*Cooling (Rated) kW	40.84	42.68	44.52
**Cooling (Rated) kW		48.26	49.21	50.16	
Heating (Rated) kW		48.58	50.60	52.62	
COP	*Cooling (Rated) kW	4.25	4.20	4.15	
	**Cooling (Rated) kW	3.02	2.99	2.97	
	Heating (Rated) kW	4.02	3.98	3.95	
Power Factor	Rated	-	0.93	0.93	
Casing	Color	Warm Gray / Dawn Gray			
Heat Exchanger	Wide Louver Plus				
	Type	Hermetically Sealed Scroll			
Compressor	Piston Displacement	cm ³ /rev	62.1 x 6	62.1 x 6	62.1 x 6
	Number of Revolution	rev/min	3,600 x 6	3,600 x 6	3,600 x 6
	Motor Output x Number	W x No.	5,300 x 6	5,300 x 6	5,300 x 6
	Starting Method	Direct On Line			
	Oil Type	FVC68D(PVE)			
	Fan	Type	Propeller fan		
Fan	Motor Output x Number	W	900 x 6	900 x 6	900 x 6
	Air Flow Rate(High)	m ³ /min	320 x 3	320 x 3	320 x 3
		ft ³ /min	11,301 x 3	11,301 x 3	11,301 x 3
	External Static Pressure (Max, Pa)	80			
	Drive	DC INVERTER			
Pipe Connctions	Liquid Pipe	mm(inch)	22.2(7/8)	22.2(7/8)	22.2(7/8)
	Gas Pipe	mm(inch)	44.5(1-3/4)	44.5(1-3/4)	53.98(2-1/8)
Dimensions (W x H x D)	mm		(1,240 x 1,690 x 760) x 3	(1,240 x 1,690 x 760) x 3	(1,240 x 1,690 x 760) x 3
	inch		(48-13/16 x 66-17/32 x 29-29/32) x 3	(48-13/16 x 66-17/32 x 29-29/32) x 3	(48-13/16 x 66-17/32 x 29-29/32) x 3
Net Weight	kg		281 x 3	281 x 3	281 x 3
	lbs		619 x 3	619 x 3	619 x 3
Sound Pressure Level	Cooling	dB(A)	67.8	68.6	69.3
	Heating	dB(A)	69.6	70.0	70.3
Sound Power Level	Cooling	dB(A)	90.8	90.8	90.8
	Heating	dB(A)	92.1	92.5	92.8
Communication Cable	No. x mm ² (VCTF-SB)	2C x 1.0 ~ 1.5			
Refrigerant	Refrigerant name		R410A		
	Precharged Amount in factory	kg	14.0 + 14.0 + 14.0		
		lbs	30.9 + 30.9 + 30.9		
Control		Electronic Expansion Valve			
Power Supply	∅, V, Hz		380-415, 3, 50		
			400, 3, 60		
Number of Maximum Connectable Indoor Units			64	64	64

NOTES

1. Capacities are based on the following conditions (ISO 15042)

- Cooling Temperature :
*Cooling (T1) : Indoor Temperature 27°C(80.6°F) DB/19°C(66.2°F) WB
Outdoor Temperature 35°C(95°F) DB/24°C(75.2°F)
**Cooling (T3) : Indoor Temperature 29°C(84.2°F) DB/19°C(66.2°F) WB
Outdoor Temperature 46°C(114.8°F) DB/24°C(75.2°F) WB
- Heating Temperature :
Indoor 20°C(68°F) DB / 15°C(59°F) WB
Outdoor 7°C(44.6°F) DB / 6°C(42.8°F) WB
- Piping Length : Interconnected Pipe Length = 7.5m
- Height difference between outdoor unit and indoor unit : 0m

2. The Maximum combination ratio is 130%.

- ### 3. Wiring cable size must comply with the applicable local and national codes.
- And "Electric characteristics" chapter should be considered for electrical work and design. Especially the power cable and circuit breaker should be selected in accordance with that.

4. Sound Level Values are measured at Anechoic chamber. Therefore, these values can be increased owing to ambient conditions during operation.

5. Power factor could vary less than ±1% according to the operating conditions.

6. Due to our policy of innovation some specifications may be changed without notification.

MULTI V S

Piping Length

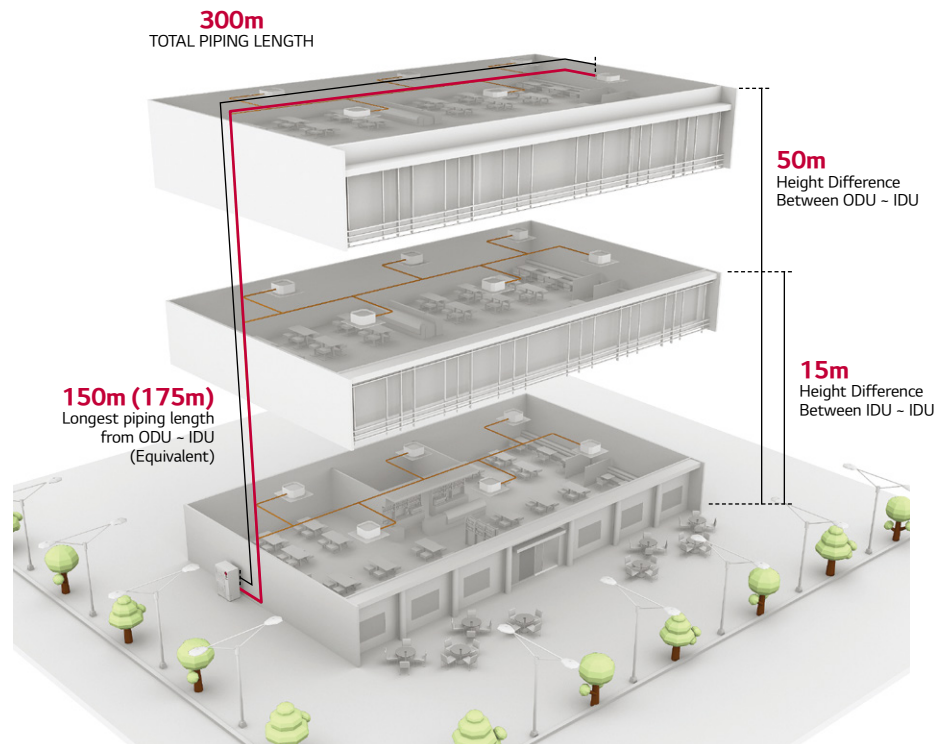

Total Piping Length	300m
Longest piping length (Equivalent)	150m (175m)
Longest piping length after 1 st branch (Conditional application)	40m (90m)
Height difference between ODU - IDU	50m
Height difference between IDU - IDU	15m

Smart Load Control Applied

Increase comfortable sensation and Max. 23% energy saving thanks to MULTI V load control

MULTI V S changes indoor discharge air temperature continuously according to load, to save energy.

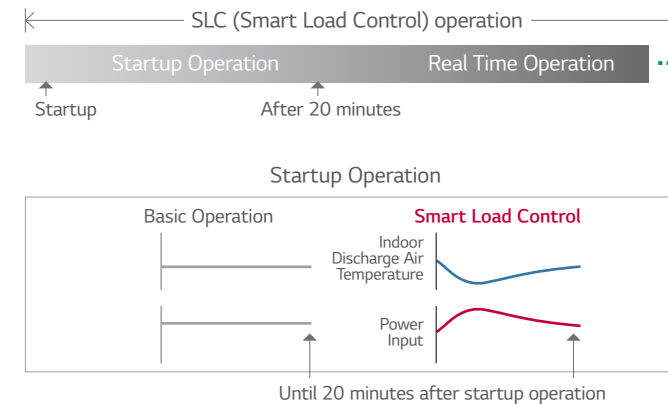

Indoor air discharge temperature
 - Energy efficiency increased by 3-step Smart Load Control during start-up phase
 - Discharge air temperature adjusted according to outdoor and indoor temperature
 - Comfort level in cooling / heating operations ensured

Max. 10% Energy saving

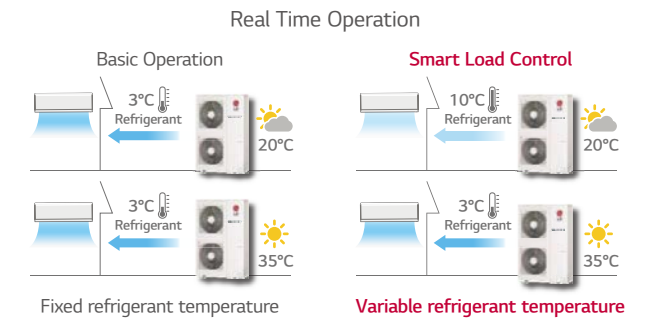

Max. 13% Energy saving

How to set up: By dip switch in outdoor unit (Referred to Product Data Book) Factory default setting is Off.

* ESEER (European seasonal energy efficiency Ratio) conditions based on 15.5kw unit
 - Outdoor temperature condition : EER 100% / 75% / 50% / 25% = 35°C(DB) / 30°C(DB) / 25°C(DB) / 20°C(DB)
 - Indoor temperature condition : 27°C(DB) / 19°C(WB)
 * Dual sensing (Temperature & humidity) smart load control is possible with Remote controller PTEMTB100 (White) / PREMTBB10 (Black)

EER/COP/Part load

Saving Energy Cost with High Efficient Product

Heat Pump

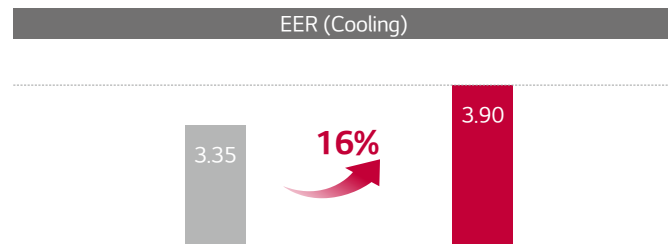

* Comparison Based on 15.5kW in cooling mode

Heat Recovery

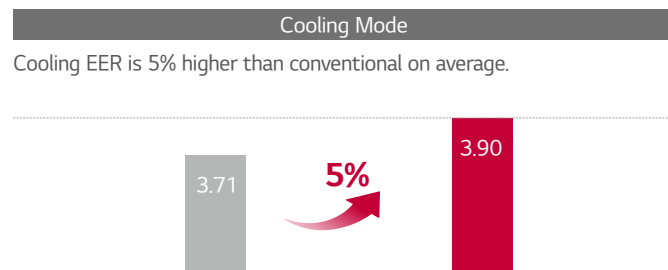

* Comparison Based on 15.5kW in cooling mode

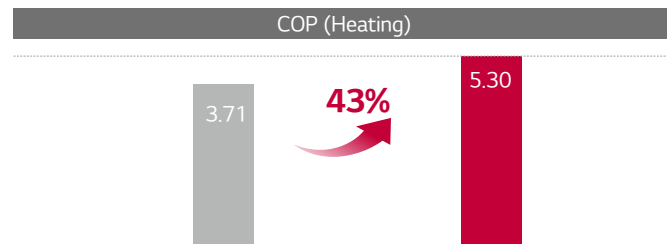

* Comparison Based on 15.5kW in heating mode

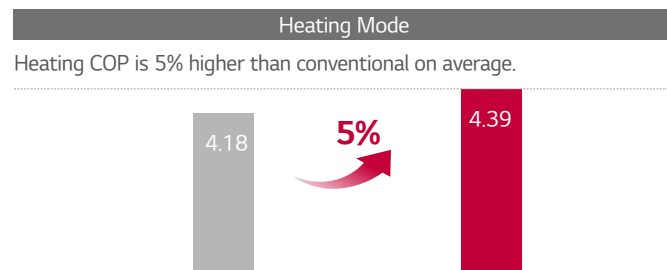

* Comparison Based on 15.5kW in heating mode

Inverter Twin Rotary & Inverter Scroll Compressor

Adapted High Efficient Compressor according to Capacity

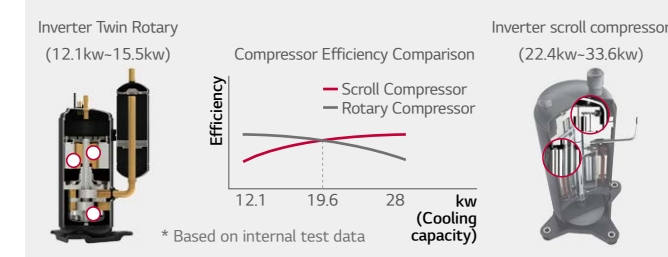

Inverter Twin Rotary

Concentrated Winding Motor

Oil path area is improved by over 50% by increasing the extra stator cavity. Due to this, caloric value of motor is reduced, improving the cooling function of stator coil.

Twin Rotary Rotor

Upper and lower part rotor offset imbalance in shaft rotor rotation. Vibration and noise is reduced. Max torque load decreased by 45% compared to single rotor.

Surface Coating

Surface coating of outstanding abrasion resistance property on vane and crank shaft.

Inverter Scroll Compressor

World Best Class Compressor Speed

- Rapid response capability
- Compact core design (Concentrated motor)
- Down to 15Hz : Part load efficiency improvement

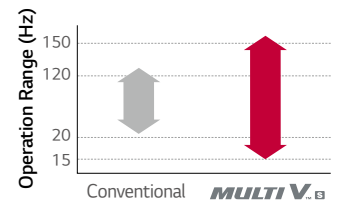

6 By-pass Valve

Compressor reliability is maximized with 6 By-pass Valve
 - Prevent compressor damage due to excessively compressed refrigerant more efficiently than 4 by-pass valve

Direct Oil Injection

- Eliminate suction refrigerant gas heat loss through direct oil injection into compression chamber (efficiency increases)
- Reliability increase due to proper oil amount supply

Scroll Profile

- The enhanced reliability by increasing the thickness of scroll central part within largest pressure
- Efficiency increases by expanding 96% bypass area and 17% improved volume ratio by non uniform scroll thickness

MULTI V S

Optimal Heat Exchanger

Maximize Efficiency according to different Heat Exchanger path by cooling and heating (LG's own technology)

Variable Heat Exchanger Circuit intelligently selects the optimal path for both heating and cooling operations. With this smart path selection technology, an average of 6% increase in the efficiency of both operations has been achieved. The paths number and circuit velocity are adjusted to match temperatures and operation modes in order to maximize efficiency instead of compromising efficiency for each operation when the number and direction of paths are fixed independently of temperature operation mode.

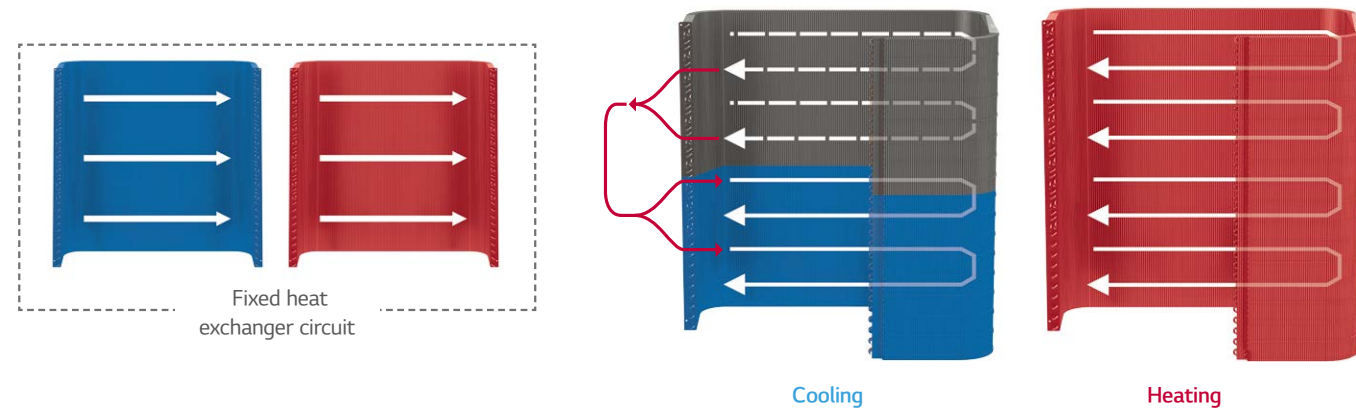

Efficiency performance

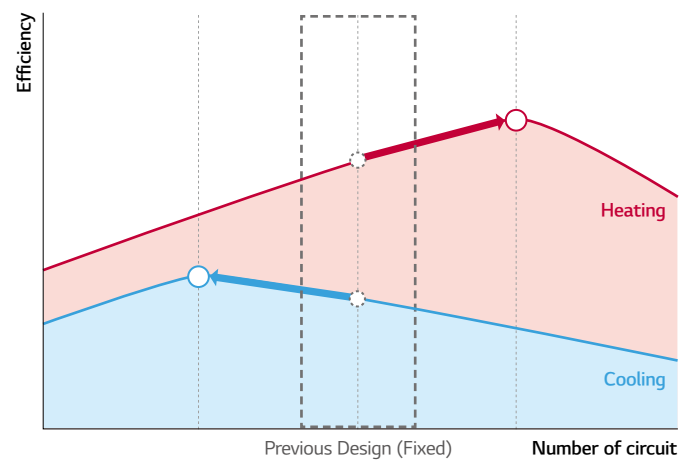

Efficiency up due to Fin shape

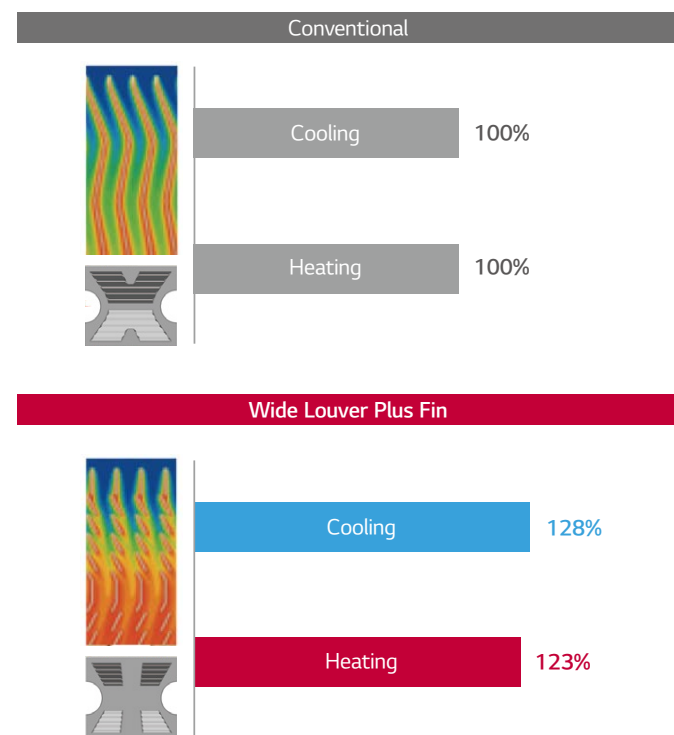

High Reliability of Refrigerant Components

Superior Performance and Strong Durable Components are developed by LG's technologies

MULTI V S improved reliability through an excellent technique of Oil separator / Accumulator / Sub-cooling.

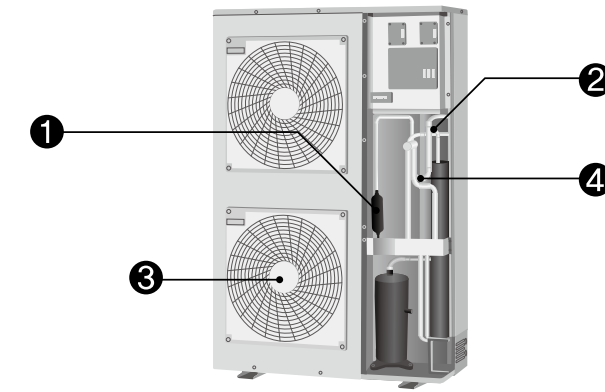

1 Cyclonic Oil Separator

- Highly reliable and efficient oil separation by centrifuge using cyclonic methods
- High collection efficiency as well as outstanding resistance to high temperature and pressure

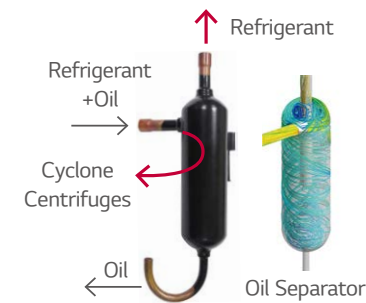

3 BLDC Fan Motor

- The BLDC Fan motor is more efficient than a conventional AC motor, offering an additional 40% energy savings at low speeds and 20% at high speeds

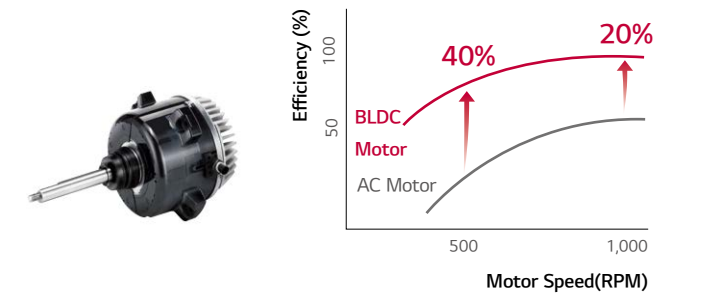

2 Large Volume Accumulator

- Improved reliability by adopting the large volume accumulator (38% volume up compared to conventional)
- Prevents the liquid refrigerant entering the compressor suction
- Maximize efficiency by optimal amount of refrigerant
- Protect compressor break down and Increase life time



4 Double Sub-cool Interchanger

- Reliability is enhanced by minimizing pressure drop due to high efficiency spiral structure and 2 times larger size
- Long pipe is possible (up to* 175m) and high elevation (up to* 50m)
- Reduction of indoor refrigerant noise level

* Based on equivalent pipe length

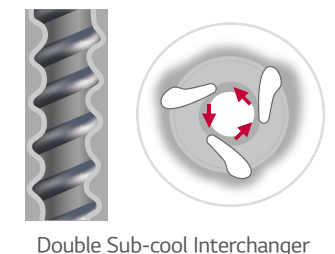

MULTI V S

Smart Control

Pressure Control applied for smart, quick, and precise responds of temperature that user requests

Temperature + Pressure Control

Senses and controls pressure directly using pressure sensor for faster and more exact response to load variation

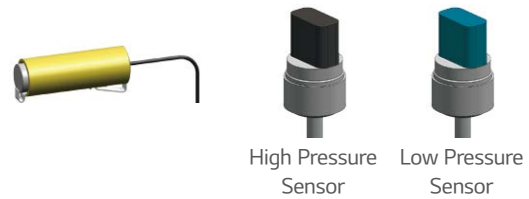

Quick Operating Response

Pressure control takes up to 14% less time in cooling mode, to reach the desired temperature. The indoor environment can be controlled more accurately and more comfortable

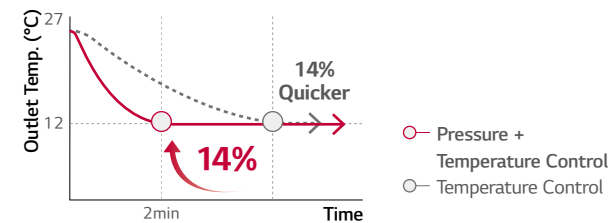

* Specifications may vary for each model.

Heat Exchanger with Ocean Black Fin for Corrosion Resistance

Strong Durability against high salinity and heavily polluted air

LG's exclusive Ocean Black Fin is applied on the heat exchanger of MULTI V S in order to perform even in corrosive environments. The strong protection from various corrosive external environments such as seaside with high salt contamination and industrial cities with severe air pollution caused by fumes from factories keeps MULTI V S operating without breakdown. This improvement in durability prolongs the product's lifespan and lowers both the operational and maintenance costs.

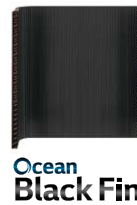

Corrosion Resistance Proven by Certified Tests

LG Corrosion Resistance solution passed ISO 21207 accelerated corrosion test conducted by an independent test organization and the result has been certified by prestigious global certification organization, UL (Underwriters Laboratories).

Certified protection



* Test Method B Simulation Validated (Test condition: Salt contaminated condition + severe industrial/traffic environment(NO_x/SO₂))

* Based on 1,500 UL test hours

Condition of salt spray test

Temperature	35°C
Mist of 5% sodium chloride solution	

Condition of gas exposure test

R.H.	NO ₂	SO _{2v}
95%	10 x 10 ⁻⁵	5 x 10 ⁻⁶

Enhanced Coating Layers

The black coating with enhanced epoxy resin is applied for strong protection from various corrosive external conditions such as salt contamination and air pollution including fumes from factories. Moreover, the hydrophilic film keeps water from accumulating on the heat exchanger's fin, minimizing moisture buildup and eventually making it even more corrosion resistant.

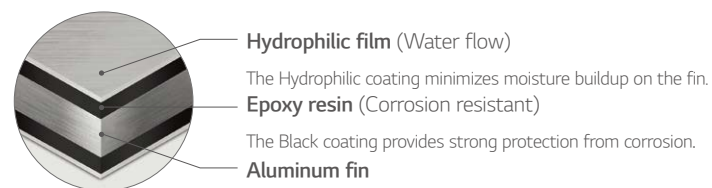

Sufficient Pipe length Limit

Sufficient pipes length limitation in Design and Installation of immense variety of building

MULTI V S inverter technology and sub cooling control circuit technology allows greater piping length and outstanding elevation differences. A cooling system can be implemented more flexibly in a shop, office and even high-rise building, reducing the designer's work time and providing more efficient design.

Piping Capabilities

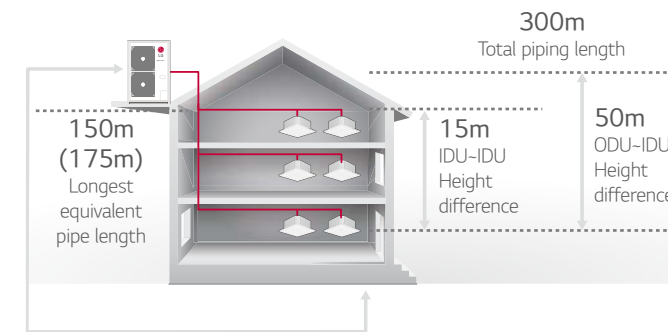

4 Way Piping

- Free design and installation by 4 way piping.

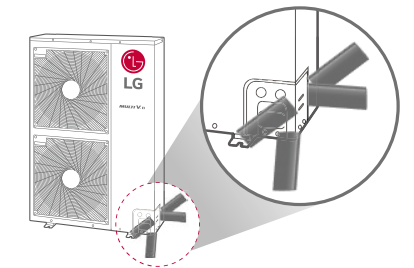

Low Noise Operation

Free from noise at any time with low noise operation function

At night mode, noise reduced maximum 14% compared to normal mode.

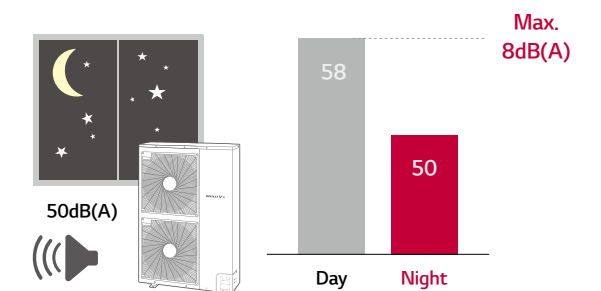
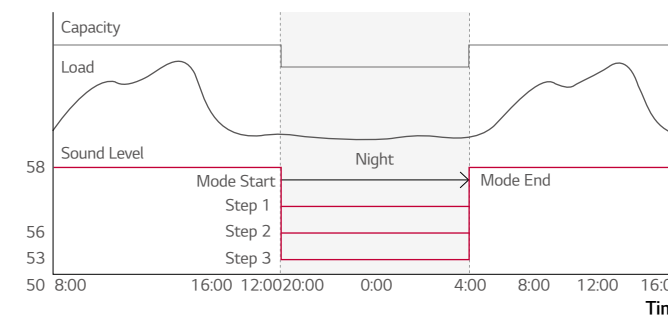

* Normal mode noise level (28kw) : 58dB(A)

* Night 3 step noise level (28kw) : 56dB(A), 53dB(A), 50dB(A)

* Sound pressure tested by following conditions : 1m distance / 1.5m height

MULTI V S

Fan Technology and RPM control

External static pressure control for outdoor unit fan to adapt more flexibly to various installation conditions of outdoor units

For efficient operation, newly developed fan blows higher air volume and has more high static pressure, also operating noise is decreased.

Fan Technology

The new axial fan has a mogul trailing edge, narrow hub blade and reverse hub, this provides a high efficiency, low noise, wide fan, as well as improving the air flow rate.

Super cannon fan increases the air volume in 50 CMM and the noise level is decreased by 4dB(A).

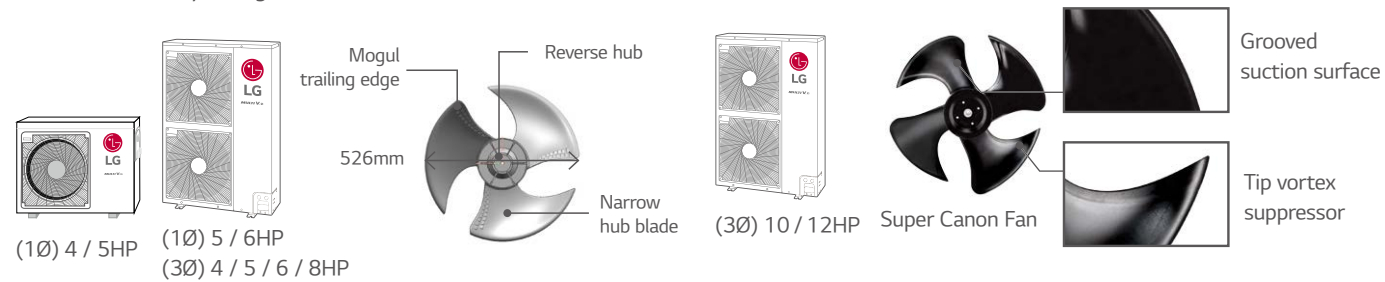

Fan RPM control

Flow of air has straightness due to fan shroud and Fan RPM control even in high-rise building.

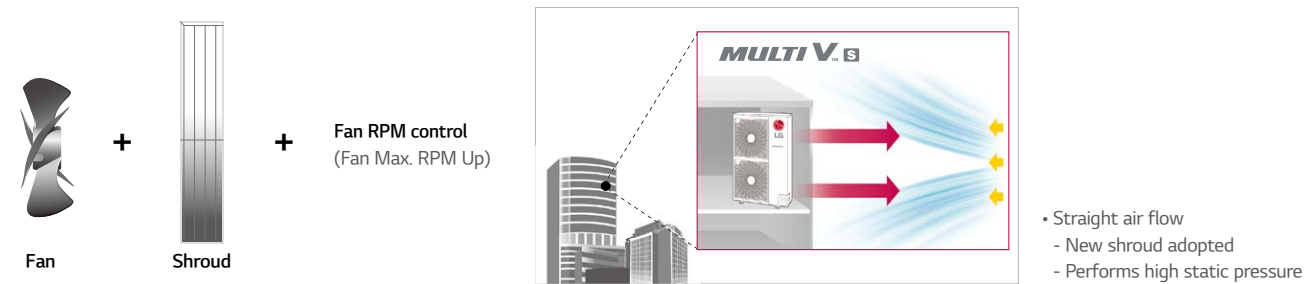

* E.S.P : External Static Pressure

Upgraded Fault Detection and Diagnosis

Easy and convenient maintenance with self-diagnosis

The inclusion of FDD elements - Auto start-up, auto refrigerant check, black box functionality, simultaneous evaluation, and auto refrigerant collection, provides the optimal solution for user reliability and ease of maintenance.

- Auto commissioning Mode
- Auto Refrigerant Collection
- Auto evaluation of refrigerant amount and charging
- Able to access LGMV (LG Monitoring View) by smartphone
- Black box function
- Piping & wiring error check-up

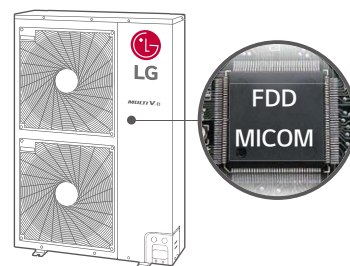

Outside Unit Function

Category	Functions	MULTI V S
Key Refrigerant Components	Variable Path of Outdoor Units HEX	-
	HiPOR™ (High Pressure Oil Return)	-
	Humidity Sensor	ARUB060GSS4 only
	Anti Corrosion Black Fin	○
	Oil Sensor	-
Special Function	Dual Sensing	ARUB060GSS4 only
	Low Noise Operation	○
	Hghj Static Mode of Outdoor Units Fan	○
	Partial Defrosting	-
	Auto Dust Cleaning of Outdoor Units (Fan reverse rotation)	-
Basic Function	Indoor Cooling Comfort Mode Based Outdoor Temperature	○
	Smart Load Control (SLC) (Changing indoor discharge air temperature according to load)	○
	Outdoor Units Control Refer to Humidity	ARUB060GSS4 only
	Defrost / Deicing	○
	High Pressure Switch	○
Central Controller	Phase Protection	○
	Restart Delay (3-minutes)	○
	Self Diagnosis	○
	Soft Start	○
	Test Run Function	-
BNU (Building Network Unit)	AC Ez (Simple Controller)	PQCSZ250S0
	AC Ez Touch	PACEZA000
	AC Smart IV	PACS4B000
	AC Smart 5	PACSSA000
	ACP (Advanced Control Platform) IV	PACP4B000
IO Module (ODU Dry Contact)	ACP (Advanced Control Platform) 5	PACPSA000
	AC Manager 5	PACMSA000
	ACP Lonworks	PLNWKB000
	ACP BACnet	PQNFB17C0
	PDI (Power Distribution Indicator)	Standard
Cool / Heat Selector	Premium	PPWRDB000
		PQNUD1S40
Cycle Monitoring Device	LGMV	PRDSBM
	Mobile LGMV	PRCTILO
Additional kit		PLGMVW100
	Refrigerant Charging Kit	○ (Logical operation) Not applied to ARUB060GSS4
	Low Ambient Kit	-
	Variable Water Flow Valve Control Kit	-

※ ○ : Applied, - : Not Applied

MULTI V S

Dimension

[Unit : mm]

Symbols

→ Piping Direction
 ▲ Datum line

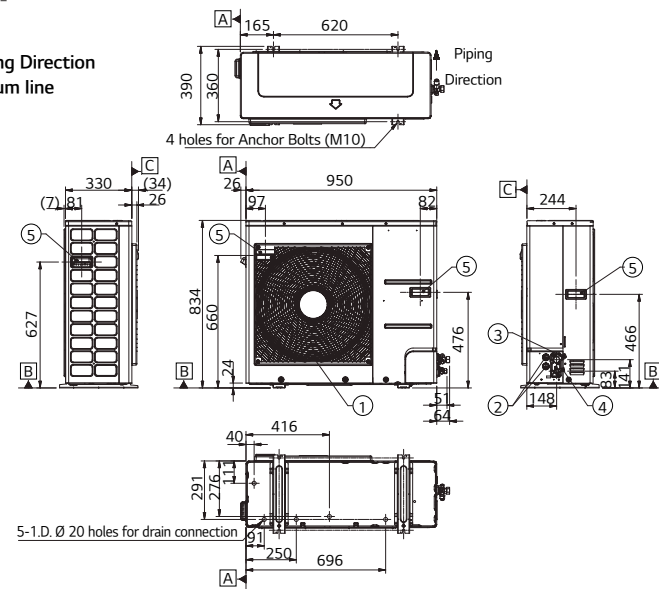

No.	Part Name	Description
1	Air Outlet	-
2	Power and communication cable Hole	-
3	Gas Pipe Connection	Welding joint
4	Liquid Pipe Connection	Welding joint
5	Handle	-
6	Pipe routing hole (front)	-
7	Pipe routing hole (side)	-
8	Pipe routing hole (back)	-

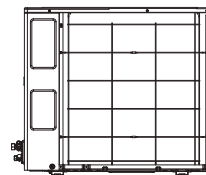
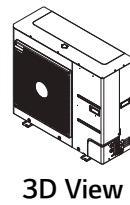

- Note
- Unit should be installed in compliance with the installation manual in the product box.
 - Unit should be grounded in accordance with the local regulation or applicable national codes.
 - All electrical components and materials to be supplied from the site must comply with the local regulations or international codes.
 - Electrical characteristics chapter should be considered for electrical work and design. Especially the power cable and circuit breaker should be selected in accordance with that.

[Unit : mm]

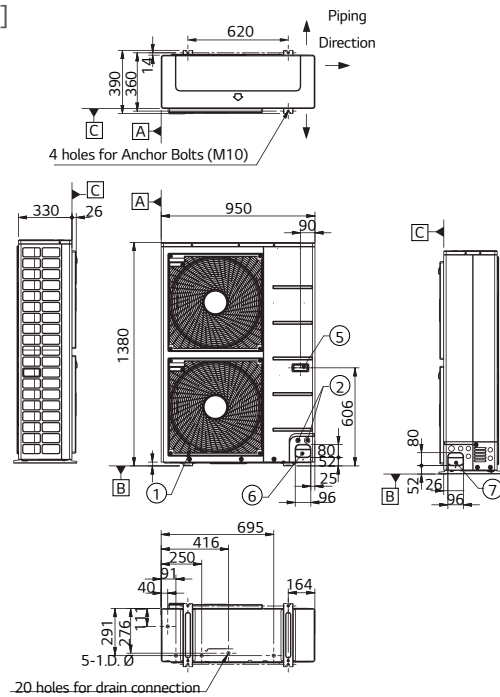

No.	Part Name	Description
1	Air Outlet	-
2	Power and communication cable Hole	-
3	Gas Pipe Connection	Welding joint
4	Liquid Pipe Connection	Welding joint
5	Handle	-
6	Pipe routing hole (front)	-
7	Pipe routing hole (side)	-
8	Pipe routing hole (back)	-

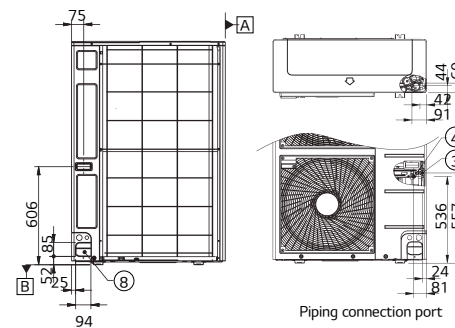

- Note
- Unit should be installed in compliance with the installation manual in the product box.
 - Unit should be grounded in accordance with the local regulation or applicable national codes.
 - All electrical components and materials to be supplied from the site must comply with the local regulations or international codes.
 - Electrical characteristics chapter should be considered for electrical work and design. Especially the power cable and circuit breaker should be selected in accordance with that.

Heat Pump

Cooling

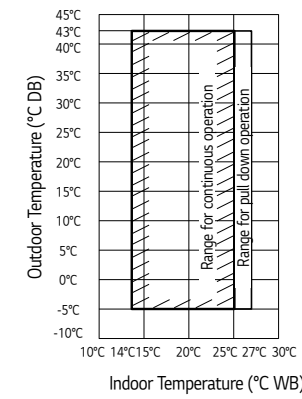

Heating

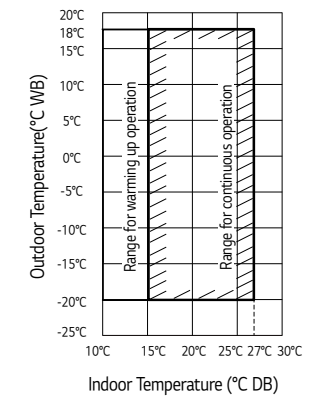

Heat Recovery

Cooling

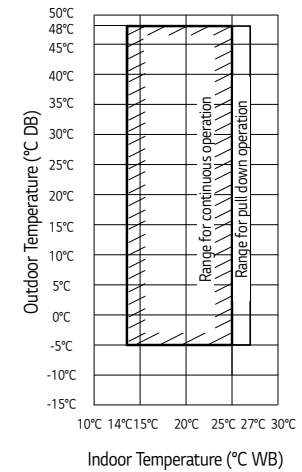

Heating

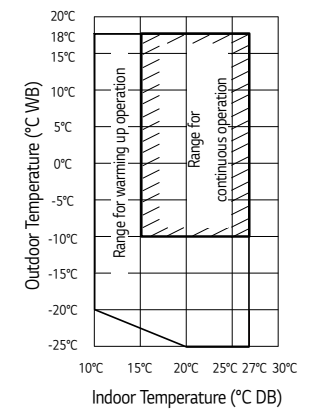

Simultaneous Cooling

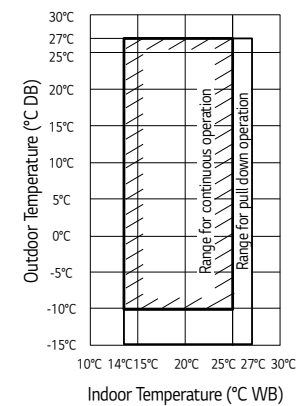

Simultaneous Heating

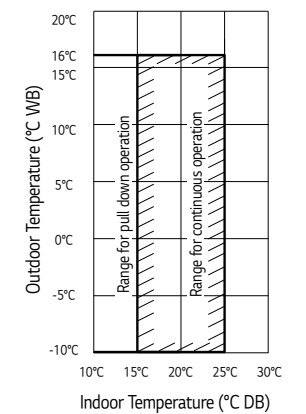

MULTI V S

Non TROPICAL MODEL

HEAT PUMP

ARUN040GSS0 / ARUN040GSR0 / ARUN050GSL0



HP			4	5
Model Name	Combination Unit		ARUN040GSS0 / ARUN040GSR0*	ARUN050GSL0
Capacity ¹⁾ (Rated)	Cooling	kW	12.1	14.0
	Heating	kW	12.5	15.0
Input (Rated) ¹⁾	Cooling	kW	3.78	4.38
	Heating	kW	2.10	2.65
EER			3.20	3.20
COP			5.94	5.66
Compressor	Type		BLDC Inverter Twin Rotary	BLDC Inverter Twin Rotary
	Piston Displacement	cm ³ /rev	44.2	44
	Motor Output	W	4,000	4,000
	Starting Method		DC Inverter Starting	DC Inverter Starting
Fan	Type		Axial Flow Fan	Axial Flow Fan
	Motor Output x Number	W	124 x 1	124 x 1
	Air Flow Rate (High)	m ³ /min	60	60
		ft ³ /min	2,119	2,119
	Drive		DC INVERTER	DC INVERTER
Discharge	Side / Top	Side	Side	
Pipe Connections	Liquid	mm(inch)	Ø 9.52(3/8)	Ø 9.52(3/8)
	Gas	mm(inch)	Ø 15.88(5/8)	Ø 15.88(5/8)
Dimensions (W x H x D)		mm	950 x 834 x 330	950 x 834 x 330
Net Weight		kg	70	73
Sound Pressure Level	Cooling	dB(A)	50	52
	Heating	dB(A)	52	58
Sound Power Level	Cooling	dB(A)	72	72
	Heating	dB(A)	75	75
Communication Cable		No. x mm ² (VCTF-SB)	2C x 1.0 - 1.5	2C x 1.0 - 1.5
Refrigerant	Refrigerant name		R410A	R410A
	Precharged Amount	kg	1.8	2.4
		lbs	4.0	5.3
	GWP		2,087.5	2,087.5
	t-CO ₂ eq		3.8	5.0
Control		Electronic Expansion Valve	Electronic Expansion Valve	
Refrigerant Oil	Type		FVC68D(PVE)	FVC68D(PVE)
	Charge	cc	1,300	1,300
Power Supply		V, Ø, Hz	220-240, 1, 50	220-240, 1, 50
			220, 1, 60	220, 1, 60
Number of Maxmum Connectable Indoor Units			8	10

* Full Corrosion Resistance Model (Heat Exchanger, Motor and Case)

- Note : 1. Eurovent Test Condition : Type of indoor unit connected is only Ceiling Concealed Duct.
 - Refer to EUROVENT certification regulation for more detail test conditions.
 - Refer to EUROVENT website for test values connected Ceiling Cassette type indoors.
 2. Performances are based on the following conditions :
 - Cooling Temperature : Indoor 27°C(80.6°F) DB / 19°C(66.2°F) WB / Outdoor 35°C(95°F) DB / 24°C(75.2°F) WB
 - Heating Temperature : Indoor 20°C(68°F) DB / 15°C(59°F) WB / Outdoor 7°C(44.6°F) DB / 6°C(42.8°F) WB
 3. The maximum combination ratio is 160% (the maximum combination ratio of ARUN050GSL0 is 130%)
 4. Wiring cable size must comply with the applicable local and national codes.
 5. Due to our policy of innovation some specifications may be changed without notification.
 6. Sound Level Values are measured at Anechoic chamber. Therefore, these values can be increased owing to ambient conditions during operation.
 7. Power factor could vary less than ±1% according to the operating conditions.
 8. This product contains Fluorinated greenhouse gases.(R410A, GWP(Global warming potential) = 2087.5)

Non TROPICAL MODEL

HEAT PUMP

ARUN050GSS0 / ARUN050GSR0 / ARUN060GSS0 / ARUN060GSR0



LG participates in the ECP programme for EUROVENT VRF program.
 Check ongoing validity of certification
 : www.eurovent-certification.com

HP			5	6
Model Name	Combination Unit		ARUN050GSS0 / ARUN050GSR0*	ARUN060GSS0 / ARUN060GSR0*
Capacity ¹⁾ (Rated)	Cooling	kW	14.0	15.5
	Heating	kW	16.0	18.0
Input (Rated) ¹⁾	Cooling	kW	3.33	3.97
	Heating	kW	2.77	3.40
EER			4.20	3.90
COP			5.77	5.30
Compressor	Type		BLDC Inverter Twin Rotary	BLDC Inverter Twin Rotary
	Piston Displacement	cm ³ /rev	44.2	44.2
	Motor Output	W	4,000	4,000
	Starting Method		DC Inverter Starting	DC Inverter Starting
Fan	Type		Axial Flow Fan	Axial Flow Fan
	Motor Output x Number	W	124 x 2	124 x 2
	Air Flow Rate (High)	m ³ /min	110	110
		ft ³ /min	3,885	3,885
	Drive		DC INVERTER	DC INVERTER
Discharge	Side / Top	Side	Side	
Pipe Connections	Liquid	mm(inch)	Ø 9.52(3/8)	Ø 9.52(3/8)
	Gas	mm(inch)	Ø 15.88(5/8)	Ø 19.05(3/4)
Dimensions (W x H x D)		mm	950 x 1,380 x 330	950 x 1,380 x 330
Net Weight		kg	94	94
Sound Pressure Level	Cooling	dB(A)	51	52
	Heating	dB(A)	53	54
Sound Power Level	Cooling	dB(A)	72	72
	Heating	dB(A)	76	77
Communication Cable		No. x mm ² (VCTF-SB)	2C x 1.0 - 1.5	2C x 1.0 - 1.5
Refrigerant	Refrigerant name		R410A	R410A
	Precharged Amount	kg	3.0	3.0
		lbs	6.6	6.6
	GWP		2,087.5	2,087.5
	t-CO ₂ eq		6.3	6.3
Control		Electronic Expansion Valve	Electronic Expansion Valve	
Refrigerant Oil	Type		FVC68D(PVE)	FVC68D(PVE)
	Charge	cc	1,300	1,300
Power Supply		V, Ø, Hz	220-240, 1, 50	220-240, 1, 50
			220, 1, 60	220, 1, 60
Number of Maxmum Connectable Indoor Units			10	13

* Full Corrosion Resistance Model (Heat Exchanger, Motor and Case)

- Note : 1. Eurovent Test Condition : Type of indoor unit connected is only Ceiling Concealed Duct.
 - Refer to EUROVENT certification regulation for more detail test conditions.
 - Refer to EUROVENT website for test values connected Ceiling Cassette type indoors.
 2. Performances are based on the following conditions :
 - Cooling Temperature : Indoor 27°C(80.6°F) DB / 19°C(66.2°F) WB / Outdoor 35°C(95°F) DB / 24°C(75.2°F) WB
 - Heating Temperature : Indoor 20°C(68°F) DB / 15°C(59°F) WB / Outdoor 7°C(44.6°F) DB / 6°C(42.8°F) WB
 3. The maximum combination ratio is 160% (the maximum combination ratio of ARUN050GSL0 is 130%)
 4. Wiring cable size must comply with the applicable local and national codes.
 5. Due to our policy of innovation some specifications may be changed without notification.
 6. Sound Level Values are measured at Anechoic chamber. Therefore, these values can be increased owing to ambient conditions during operation.
 7. Power factor could vary less than ±1% according to the operating conditions.
 8. This product contains Fluorinated greenhouse gases.(R410A, GWP(Global warming potential) = 2087.5)

MULTI V S

Non TROPICAL MODEL

HEAT PUMP

ARUN040LSSO / ARUN050LSSO / ARUN060LSSO
ARUN040LSRO / ARUN050LSRO / ARUN060LSRO



LG participates in the ECP programme for EUROVENT VRF program.
Check ongoing validity of certification
: www.eurovent-certification.com

HP		4	5	6
Model Name	Combination Unit	ARUN040LSSO / ARUN040LSRO*	ARUN050LSSO / ARUN050LSRO*	ARUN060LSSO / ARUN060LSRO*
Capacity ¹⁾ (Rated)	Cooling	kW 12.1	14.0	15.5
	Heating	kW 12.5	16.0	18.0
Input (Rated) ¹⁾	Cooling	kW 2.37	3.33	3.97
	Heating	kW 1.93	2.77	3.40
EER		5.10	4.20	3.90
COP		6.49	5.77	5.30
Compressor	Type	BLDC Inverter Twin Rotary	BLDC Inverter Twin Rotary	BLDC Inverter Twin Rotary
	Piston Displacement	cm ³ /rev 44.2	44.2	44.2
	Motor Output	W 4,000	4,000	4,000
	Starting Method	DC Inverter Starting	DC Inverter Starting	DC Inverter Starting
Fan	Type	Axial Flow Fan	Axial Flow Fan	Axial Flow Fan
	Motor Output x Number	W 124 x 2	124 x 2	124 x 2
	Air Flow Rate (High)	m ³ /min 110	110	110
		ft ³ /min 3,885	3,885	3,885
	Drive	DC INVERTER	DC INVERTER	DC INVERTER
Discharge	Side / Top	Side	Side	
Pipe Connections	Liquid	mm(inch) Ø 9.52(3/8)	Ø 9.52(3/8)	Ø 9.52(3/8)
	Gas	mm(inch) Ø 15.88(5/8)	Ø 15.88(5/8)	Ø 19.05(3/4)
Dimensions (W x H x D)	mm	950 x 1,380 x 330	950 x 1,380 x 330	950 x 1,380 x 330
Net Weight	kg	96	96	96
Sound Pressure Level	Cooling	dB(A) 50	51	52
	Heating	dB(A) 52	53	54
Sound Power Level	Cooling	dB(A) 72	72	72
	Heating	dB(A) 76	76	77
Communication Cable	No. x mm ² (VCTF-SB)	2C x 1.0 - 1.5	2C x 1.0 - 1.5	2C x 1.0 - 1.5
Refrigerant	Refrigerant name	R410A	R410A	R410A
	Precharged Amount	kg 3.0	3.0	3.0
		lbs 6.6	6.6	6.6
	GWP	2,087.5	2,087.5	2,087.5
	t-CO ₂ eq	6.3	6.3	6.3
Control	Electronic Expansion Valve	Electronic Expansion Valve	Electronic Expansion Valve	
Refrigerant Oil	Type	FVC68D(PVE)	FVC68D(PVE)	FVC68D(PVE)
	Charge	cc 1,300	1,300	1,300
Power Supply	V, Ø, Hz	380-415, 3, 50	380-415, 3, 50	380-415, 3, 50
		380, 3, 60	380, 3, 60	380, 3, 60
Number of Maxmum Connectable Indoor Units		8	10	13

* Full Corrosion Resistance Model (Heat Exchanger, Motor and Case)

- Note : 1. Eurovent Test Condition : Type of indoor unit connected is only Ceiling Concealed Duct.
- Refer to EUROVENT certification regulation for more detail test conditions.
- Refer to EUROVENT website for test values connected Ceiling Cassette type indoors.
2. Performances are based on the following conditions :
- Cooling Temperature : Indoor 27°C(80.6°F) DB / 19°C(66.2°F) WB / Outdoor 35°C(95°F) DB / 24°C(75.2°F) WB
- Heating Temperature : Indoor 20°C(68°F) DB / 15°C(59°F) WB / Outdoor 7°C(44.6°F) DB / 6°C(42.8°F) WB
3. The maximum combination ratio is 160% (the maximum combination ratio of ARUN050GSLO is 130%)
4. Wiring cable size must comply with the applicable local and national codes.
5. Due to our policy of innovation some specifications may be changed without notification.
6. Sound Level Values are measured at Anechoic chamber. Therefore, these values can be increased owing to ambient conditions during operation.
7. Power factor could vary less than ±1% according to the operating conditions.
8. This product contains Fluorinated greenhouse gases.(R410A, GWP(Global warming potential) = 2087.5)

Non TROPICAL MODEL

HEAT PUMP

ARUN080LSSO / ARUN100LSSO / ARUN120LSSO



LG participates in the ECP programme for EUROVENT VRF program.
Check ongoing validity of certification
: www.eurovent-certification.com

HP		8	10	12
Model Name	Combination Unit	ARUN080LSSO	ARUN100LSSO	ARUN120LSSO
Capacity ¹⁾ (Rated)	Cooling	kW 22.4	28.0	33.6
	Heating	kW 24.5	30.6	36.7
Input (Rated) ¹⁾	Cooling	kW 8.30	8.75	14.00
	Heating	kW 6.62	8.12	7.46
EER		2.70	3.20	2.40
COP		3.70	3.77	4.92
Compressor	Type	Hermetically Sealed Scroll	Hermetically Sealed Scroll	Hermetically Sealed Scroll
	Piston Displacement	cm ³ /rev 43.8	62.1	62.1
	Motor Output	W 4,200	5,300	5,300
	Starting Method	Direct On Line	Direct On Line	Direct On Line
Fan	Type	Propeller fan	Propeller fan	Propeller fan
	Motor Output x Number	W 124 x 2	250 x 2	250 x 2
	Air Flow Rate (High)	m ³ /min 140	190	190
		ft ³ /min 4,944	6,710	6,710
	Drive	DC INVERTER	DC INVERTER	DC INVERTER
Discharge	Side / Top	Side	Side	
Pipe Connections	Liquid	mm(inch) Ø 9.52(3/8)	Ø 9.52(3/8)	Ø 12.7(1/2)
	Gas	mm(inch) Ø 19.05(3/4)	Ø 22.2(7/8)	Ø 28.58(1 1/8)
Dimensions (W x H x D)	mm	950 x 1,380 x 330	1,090 x 1,625 x 380	1,090 x 1,625 x 380
Net Weight	kg	115	144	157
Sound Pressure Level	Cooling	dB(A) 57	58	60
	Heating	dB(A) 57	58	60
Sound Power Level	Cooling	dB(A) 81	80	81
	Heating	dB(A) 84	84	85
Communication Cable	No. x mm ² (VCTF-SB)	2C x 1.0 - 1.5	2C x 1.0 - 1.5	2C x 1.0 - 1.5
Refrigerant	Refrigerant name	R410A	R410A	R410A
	Precharged Amount	kg 3.5	4.5	6.0
		lbs 7.7	9.9	13.2
	GWP	2,087.5	2,087.5	2,087.5
	t-CO ₂ eq	7.3	9.4	12.5
Control	Electronic Expansion Valve	Electronic Expansion Valve	Electronic Expansion Valve	
Refrigerant Oil	Type	FVC68D(PVE)	FVC68D(PVE)	FVC68D(PVE)
	Charge	cc 2,400	2,600	3,400
Power Supply	V, Ø, Hz	380-415, 3, 50	380-415, 3, 50	380-415, 3, 50
		380, 3, 60	380, 3, 60	380, 3, 60
Number of Maxmum Connectable Indoor Units		13	16	20

- Note : 1. Eurovent Test Condition : Type of indoor unit connected is only Ceiling Concealed Duct.
- Refer to EUROVENT certification regulation for more detail test conditions.
- Refer to EUROVENT website for test values connected Ceiling Cassette type indoors.
2. Performances are based on the following conditions :
- Cooling Temperature : Indoor 27°C(80.6°F) DB / 19°C(66.2°F) WB / Outdoor 35°C(95°F) DB / 24°C(75.2°F) WB
- Heating Temperature : Indoor 20°C(68°F) DB / 15°C(59°F) WB / Outdoor 7°C(44.6°F) DB / 6°C(42.8°F) WB
3. The maximum combination ratio is 160% (the maximum combination ratio of ARUN050GSLO is 130%)
4. Wiring cable size must comply with the applicable local and national codes.
5. Due to our policy of innovation some specifications may be changed without notification.
6. Sound Level Values are measured at Anechoic chamber. Therefore, these values can be increased owing to ambient conditions during operation.
7. Power factor could vary less than ±1% according to the operating conditions.
8. This product contains Fluorinated greenhouse gases.(R410A, GWP(Global warming potential) = 2087.5)

MULTI V S

Non TROPICAL MODEL

HEAT RECOVERY

ARUB060GSS4

LG participates in the ECP programme for EUROVENT VRF program. Check ongoing validity of certification : www.eurovent-certification.com



HP	6			
Model	ARUB060GSS4			
Capacity (Rated) ¹⁾	Cooling	Nom	kW	15.5
	Heating	Nom	kW	18.0
Power Input (Rated) ¹⁾	Cooling	Nom	kW	3.97
	Heating	Nom	kW	4.10
EER				3.90
COP				4.39
ESEER				7.15
SLC ESEER				8.05
Compressor	Type	Hermetically Sealed Scroll		
	Piston Displacement	cm ³ /rev	43.8	
	Motor Output	W	4,200	
	Starting Method	DC Inverter Starting		
Fan	Type	Axial Flow Fan		
	Motor Output x Number	W	124 x 2	
	Air Flow Rate (High)	m ³ /min	110	
		ft ³ /min	3,885	
Drive	DC INVERTER			
Pipe Connections	Discharge	Side / Top	Side	
	Liquid	mm(inch)	Ø 9.52 (3/8)	
	Low Pressure Gas	mm(inch)	Ø 19.05 (3/4)	
	High Pressure Gas	mm(inch)	Ø 15.88 (5/8)	
Dimensions (W x H x D)	mm	950 x 1,380 x 330		
Net Weight	kg	118		
Sound Pressure Level	Cooling	dB(A)	56	
	Heating	dB(A)	58	
Sound Power Level	Cooling	dB(A)	69	
	Heating	dB(A)	71	
Communication Cable	(VCTF-SB)	No. x mm ²	2C x 1.0 - 1.5	
Refrigerant	Refrigerant Name	R410A		
	Pre-charged Amount	kg	3.5	
	t-CO ₂ eq	7.3		
	Control	Electronic Expansion Valve		
Refrigerant Oil	Type	FVC68D(PVE)		
	Charge	cc	1,300	
Power Supply	V, Ø, Hz	220-240, 1, 50		
Number of Maximum Connectable Indoor Units				13

- Note : 1. Eurovent Test Condition : Type of indoor unit connected is only Ceiling Concealed Duct.
 - Refer to EUROVENT certification regulation for more detail test conditions.
 - Refer to EUROVENT website for test values connected Ceiling Cassette type indoors.
 2. Performances are based on the following conditions :
 - Cooling Temperature : Indoor 27°C(80.6°F) DB / 19°C(66.2°F) WB / Outdoor 35°C(95°F) DB / 24°C(75.2°F) WB
 - Heating Temperature : Indoor 20°C(68°F) DB / 15°C(59°F) WB / Outdoor 7°C(44.6°F) DB / 6°C(42.8°F) WB
 3. The maximum combination ratio is 160% (the maximum combination ratio of ARUN050GSL0 is 130%)
 4. Wiring cable size must comply with the applicable local and national codes.
 5. Due to our policy of innovation some specifications may be changed without notification.
 6. Sound Level Values are measured at Anechoic chamber. Therefore, these values can be increased owing to ambient conditions during operation.
 7. Power factor could vary less than ±1% according to the operating conditions.
 8. This product contains Fluorinated greenhouse gases.(R410A, GWP(Global warming potential) = 2087.5)

TROPICAL MODEL

HEAT PUMP

ARUN040LSHO / ARUN050LSHO / ARUN060LSHO



HP	4			5			6					
Model Name	Independent Unit			ARUN040LSHO			ARUN050LSHO			ARUN060LSHO		
Capacity (Rated) ¹⁾	*Cooling - T1 35°C	RT	3.2			4.0			4.4			
		kW	11.2			14.0			15.5			
	**Cooling - T3 46°C	Btu/h	38,200			47,800			52,900			
		kW	2.7			3.4			3.8			
	Heating	Btu/h	32,400			40,600			45,000			
		kW	3.6			4.5			5.1			
Input (Rated) ¹⁾	*Cooling - T1 35°C	kW	2.60			3.38			3.96			
		kW	2.80			3.66			4.26			
	**Cooling - T3 46°C	kW	2.75			3.52			4.09			
		kW / kW	4.31			4.14			3.91			
	Heating	kW / kW	3.40			3.25			3.10			
		kW / kW	4.55			4.55			4.40			
Power Factor	Rated	-	0.93			0.93			0.93			
Casing Color				Warm Gray			Warm Gray			Warm Gray		
Heat Exchanger				Wide Louver Plus			Wide Louver Plus			Wide Louver Plus		
Compressor	Type	DC Inverter Rotary			DC Inverter Rotary			DC Inverter Rotary				
	Piston Displacement	cm ³ /rev	44.2			44.2			44.2			
	Number of Revolution	rev/min	3,600			3,600			3,600			
	Motor Output x Number	W x No.	4,000 x 1			4,000 x 1			4,000 x 1			
	Starting Method	Inverter			Inverter			Inverter				
	Oil Type	FVC68D(PVE)			FVC68D(PVE)			FVC68D(PVE)				
Fan	Type	Propeller fan			Propeller fan			Propeller fan				
	Motor Output x Number	W	124 x 2			124 x 2			124 x 2			
	Air Flow Rate (High)	m ³ /min	110			110			110			
		ft ³ /min	3,885			3,885			3,885			
Drive	DC INVERTER			DC INVERTER			DC INVERTER					
Discharge	Side / Top	Side			Side			Side				
Piping Connections	Liquid	mm(inch)	Ø 9.52(3/8)			Ø 9.52(3/8)			Ø 9.52(3/8)			
	Gas	mm(inch)	Ø 15.88(5/8)			Ø 15.88(5/8)			Ø 19.05(3/4)			
Dimensions (W x H x D)	mm	(950x1,380x330)			(950x1,380x330)			(950x1,380x330)				
	inch	(37.4 x 54.3 x 13.0)			(37.4 x 54.3 x 13.0)			(37.4 x 54.3 x 13.0)				
Net Weight	kg	96			96			96				
	lbs	212			212			212				
Sound Press Level	Cooling	dB(A)	50.0			51.0			52.0			
	Heating	dB(A)	52.0			53.0			54.0			
Sound Power Level	dB(A)	63			66			67				
Communication Cable	No. x mm ² (VCTF-SB)	2C x 1.0 - 1.5			2C x 1.0 - 1.5			2C x 1.0 - 1.5				
Refrigerant	Refrigerant name	R410A			R410A			R410A				
	Pre-charged Amount	kg	3.0			3.0			3.0			
		lbs	6.6			6.6			6.6			
	Control	Electronic Expansion Valve			Electronic Expansion Valve			Electronic Expansion Valve				
Power Supply	V, Ø, Hz	380-415, 3, 50			380-415, 3, 50			380-415, 3, 50				
	V, Ø, Hz	400, 3, 60			400, 3, 60			400, 3, 60				
Number of Maximum Connectable Indoor Units				6			8			9		

- Note : 1. Capacities are based on the following conditions (ISO 15042)
 - Cooling Temperature : *Cooling (T1) : Indoor Temperature 27°C(80.6°F) DB/19°C(66.2°F) WB / Outdoor Temperature 35°C(95°F) DB/24°C(75.2°F)
 **Cooling (T3) : Indoor Temperature 29°C(84.2°F) DB/19°C(66.2°F) WB / Outdoor Temperature 46°C(114.8°F) DB/24°C(75.2°F) WB
 - Heating Temperature : Indoor 20°C(68°F) DB / 15°C(59°F) WB / Outdoor 7°C(44.6°F) DB / 6°C(42.8°F) WB
 - Piping Length : Interconnected Pipe Length = 7.5m
 - Height difference between outdoor unit and indoor unit : 0m
 2. The Maximum combination ratio is 130%.
 3. Wiring cable size must comply with the applicable local and national codes. And "Electric characteristics" chapter should be considered for electrical work and design. Especially the power cable and circuit breaker should be selected in accordance with that.
 4. Sound Level Values are measured at Anechoic chamber. Therefore, these values can be increased owing to ambient conditions during operation.
 5. Power factor could vary less than ±1% according to the operating conditions.
 6. Due to our policy of innovation some specifications may be changed without notification.

TROPICAL MODEL

HEAT PUMP

ARUN080LSH0 / ARUN100LSH0



HP		8	10	
Model Name	Independent Unit	ARUN080LSH0	ARUN100LSH0	
Capacity (Rated) ¹⁾	*Cooling - T1 35°C	RT	6.4	8.0
		kW	22.4	28.0
	**Cooling - T3 46°C	Btu/h	76,400	95,900
		RT	5.4	7.1
	Heating	kW	19.0	25.0
		Btu/h	64,900	85,300
Input (Rated) ¹⁾	*Cooling - T1 35°C	RT	7.2	9.0
		kW	25.2	31.5
	**Cooling - T3 46°C	kW	86,000	107,500
		Btu/h	5.60	7.09
	Heating	kW	5.94	7.94
		Btu/h	5.86	7.41
COP ¹⁾	*Cooling - T1 35°C	kW / kW	4.00	3.95
	**Cooling - T3 46°C	kW / kW	3.20	3.15
	Heating	kW / kW	4.30	4.25
Power Factor	Rated	-	0.93	0.93
Casing Color		Warm Gray	Warm Gray	
Heat Exchanger		Wide Louver Plus	Wide Louver Plus	
Compressor	Type	Hermetically Sealed Scroll	Hermetically Sealed Scroll	
	Piston Displacement	cm ³ /rev	62.1	62.1
	Number of Revolution	rev/min	3,600	3,600
	Motor Output x Number	W x No.	5,300 x 1	5,300 x 1
	Starting Method		Inverter	Inverter
	Oil Type		FVC68D(PVE)	FVC68D(PVE)
Fan	Type	Propeller fan	Propeller fan	
	Motor Output x Number	W	250 x 2	251 x 2
	Air Flow Rate (High)	m ³ /min	190	190
		ft ³ /min	6,707	6,707
	Drive		DC INVERTER	DC INVERTER
	Discharge	Side / Top	Side	Side
Piping Connections	Liquid	mm(inch)	Ø 9.52(3/8)	Ø 9.52(3/8)
	Gas	mm(inch)	Ø 19.05(3/4)	Ø 22.2(7/8)
Dimensions (W x H x D)	mm	(1,090 x 1,625 x 380)	(1,090 x 1,625 x 380)	
	inch	(42.9 x 64.0 x 15.0)	(42.9 x 64.0 x 15.0)	
Net Weight	kg	144	144	
	lbs	317	317	
Sound Press Level	Cooling	dB(A)	57.0	58.0
	Heating	dB(A)	57.0	58.0
Sound Power Level		dB(A)	68	69
Communication Cable	No. x mm ² (VCTF-SB)	2C x 1.0 - 1.5	2C x 1.0 - 1.5	
Refrigerant	Refrigerant name		R410A	R410A
	Precharged Amount	kg	4.5	4.5
		lbs	9.9	9.9
Power Supply	Control		Electronic Expansion Valve	Electronic Expansion Valve
	V, Ø, Hz		380-415, 3, 50	380-415, 3, 50
Number of Maxmum Connectable Indoor Units		400, 3, 60	400, 3, 60	
		13	16	

Note : 1. Capacities are based on the following conditions (ISO 15042)
 - Cooling Temperature : *Cooling (T1) : Indoor Temperature 27°C(80.6°F) DB/19°C(66.2°F) WB / Outdoor Temperature 35°C(95°F) DB/24°C(75.2°F)
 **Cooling (T3) : Indoor Temperature 29°C(84.2°F) DB/19°C(66.2°F) WB / Outdoor Temperature 46°C(114.8°F) DB/24°C(75.2°F) WB
 - Heating Temperature : Indoor 20°C(68°F) DB / 15°C(59°F) WB / Outdoor 7°C(44.6°F) DB / 6°C(42.8°F) WB
 - Piping Length : Interconnected Pipe Length = 7.5m
 - Height difference between outdoor unit and indoor unit : 0m
 2. The Maximum combination ratio is 130%.
 3. Wiring cable size must comply with the applicable local and national codes. And "Electric characteristics" chapter should be considered for electrical work and design. Especially the power cable and circuit breaker should be selected in accordance with that.
 4. Sound Level Values are measured at Anechoic chamber. Therefore, these values can be increased owing to ambient conditions during operation.
 5. Power factor could vary less than ±1% according to the operating conditions.
 6. Due to our policy of innovation some specifications may be changed without notification.

System Diagram

Providing a total solution by heat pump, air conditioning (cooling by refrigerant & chilled water, heating by refrigerant & hot water) and domestic hot water supply.

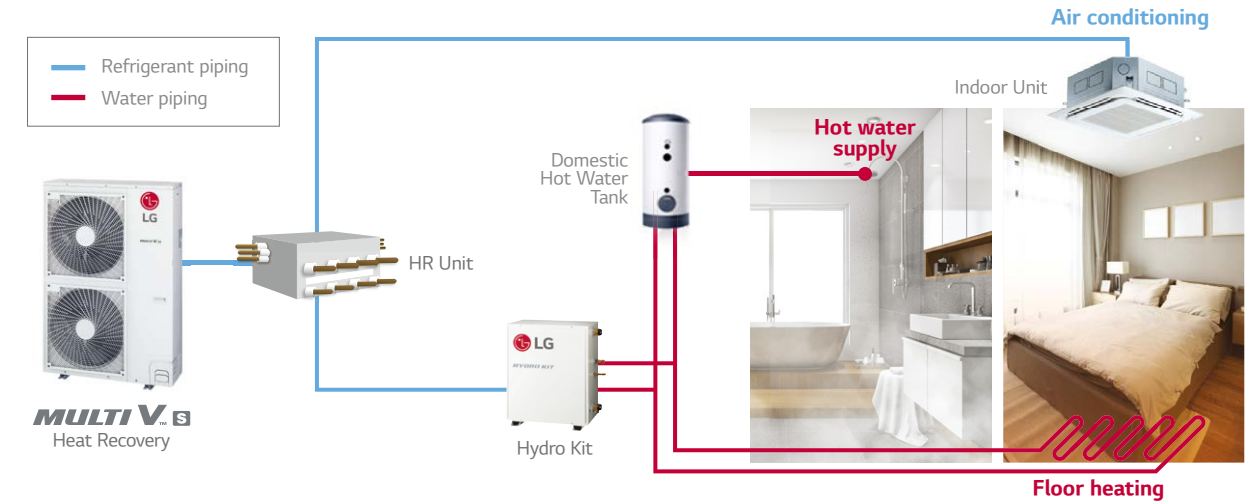

Energy Saving

Energy consumption can be reduced since absorbed heat from indoor space is used for supplying hot water.

Conventional

Absorbed heat is released to outdoor air.

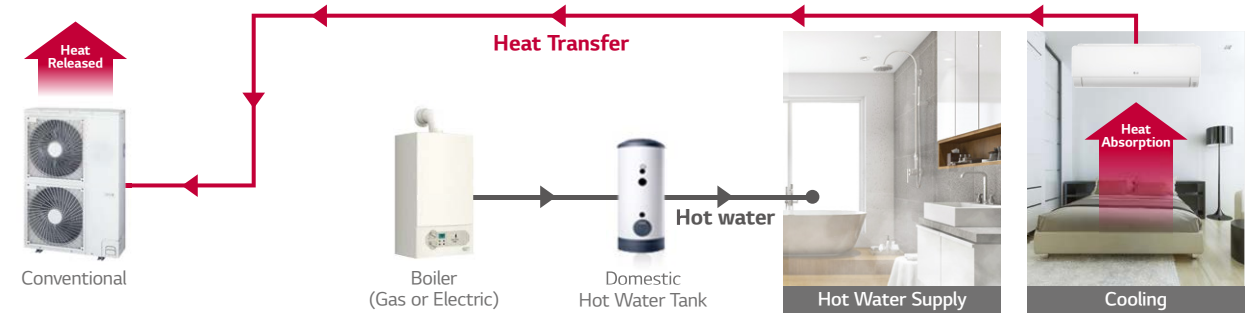

MULTI V S Heat Recovery with HYDRO KIT

Absorbed heat from indoor space is used for making hot water.

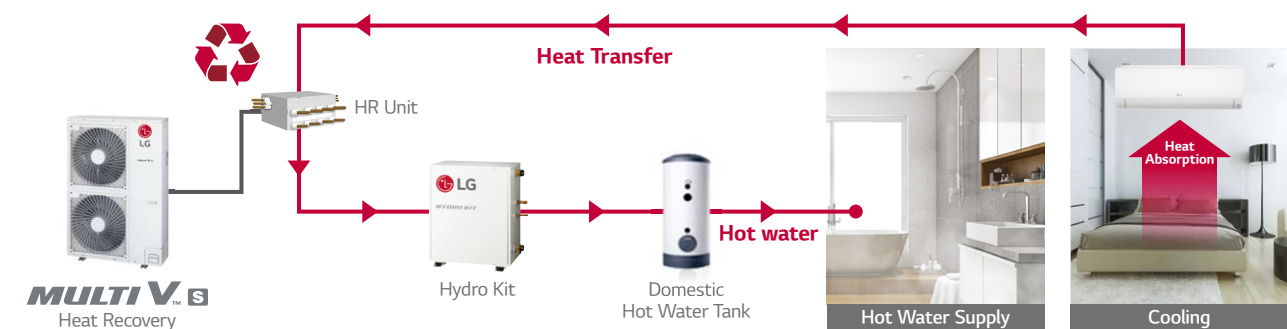

MULTI V MODULAR

Bird's-eye view

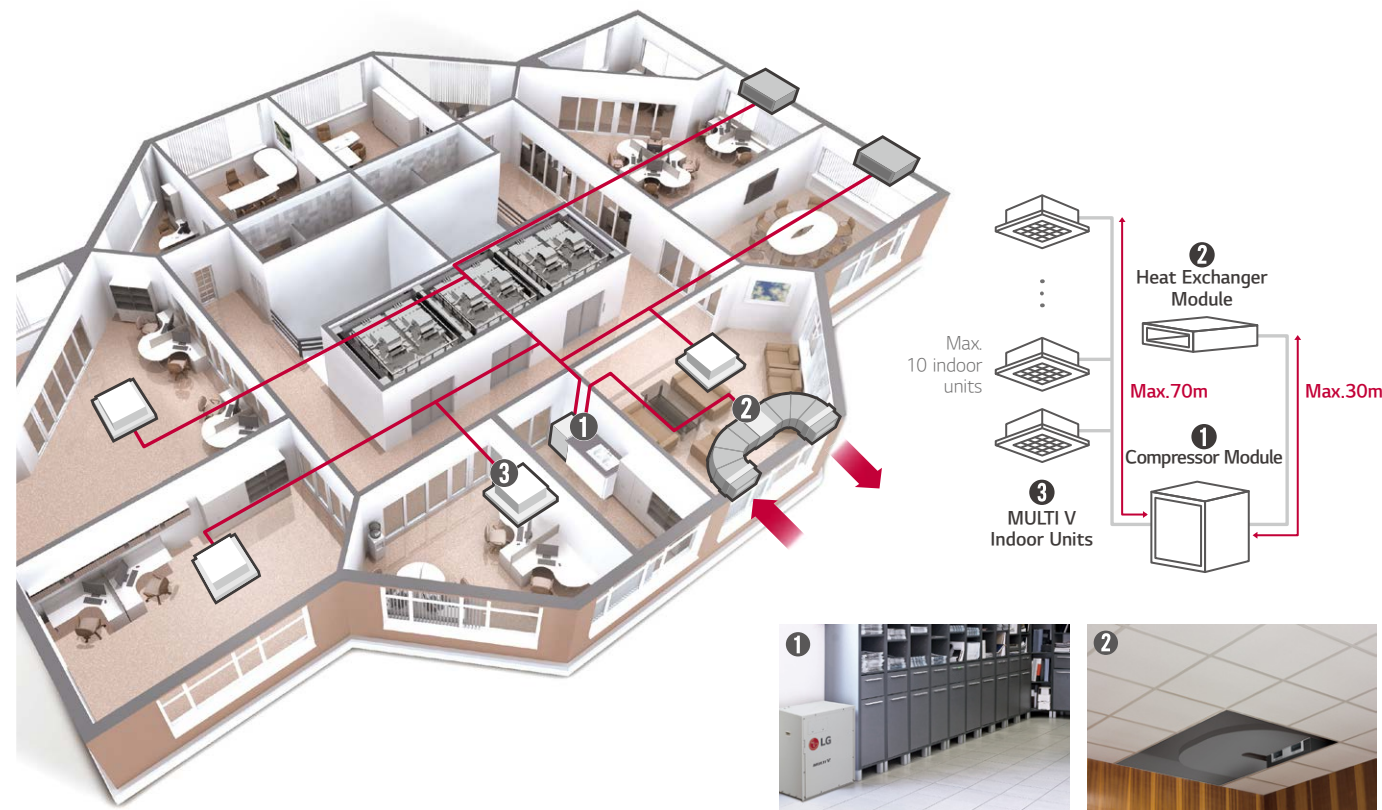

High Flexibility of Installation

Outside unit split by compressor and heat exchanger module

Split unit can make installation much more flexible. Compressor module can be installed at any place inside such as storage room, or in a kitchen. Heat exchanger module can be installed in a false ceiling spaces in both case of direct inlet/outlet and ducted inlet/outlet. Higher maximum external static pressure can make installation more flexible

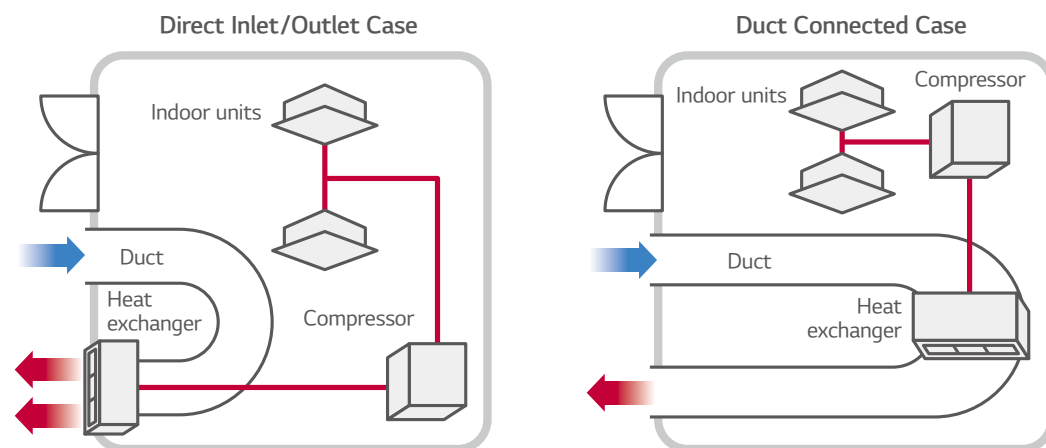

Lighter & smaller units can make installation much more easier

Ease and flexibility of installation

Ease and flexibility of installation thanks to the high static pressure available and adjustable and the reduced weight

Small size

Make the most of your local space thanks to its small size

Regulatory compliance

Regulatory compliance thanks to the 3600 CMM of exhausted air

Increased Freedom of Design

Additional structure installation or ceiling construction isn't required due to improved freedom of design. This makes replacement of the compressor easier, making the service and maintenance of products handy. Moreover, split module provides low noise operation in comparison to the integrated type.



Heat exchanger module can be installed in false ceiling spaces



Compressor module can be installed at any place inside



Space Saving & Convenient Installation

Volume (Compressor Module)

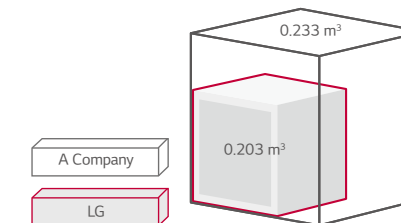

Volume (Heat Exchanger Module)

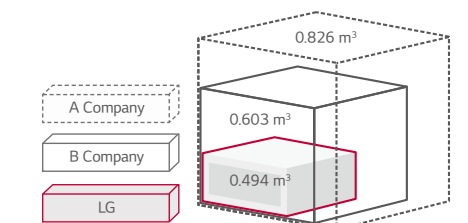

E.S.P. (External Static Pressure) Control

Normal Mode

up to 30 Pa

High Static Pressure Mode

up to 157 Pa (max)



MULTI V MODULAR

Wide Louver Plus Fin + Corrosion Resistance

Wide Louver Plus fin technology increases efficiency and heating performance compared to conventional fin.

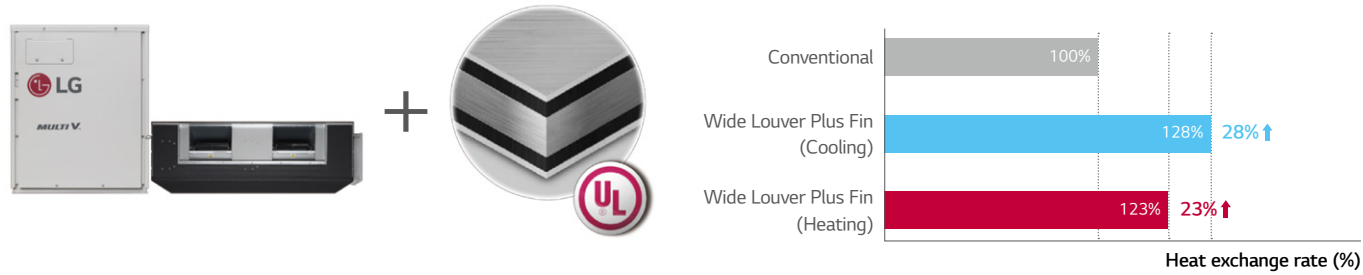

Module Type

Increased freedom of design

- Additional structure installation and ceiling construction isn't required

Ease of service (Replacement of the comp)

Low noise by module (vs Integrated Type)

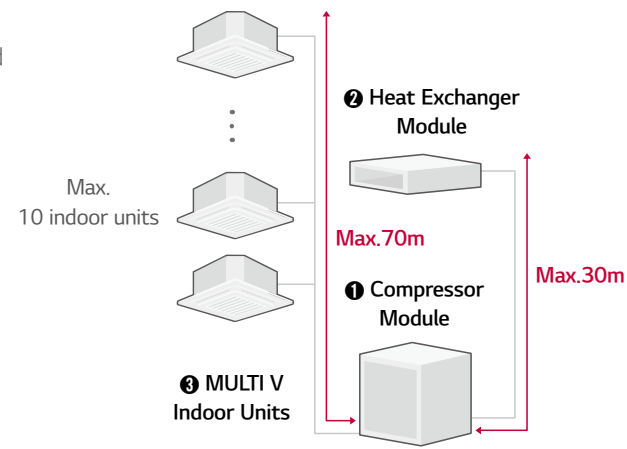

Flexible Piping Location

Neat & easy installation by flexible piping location piping.

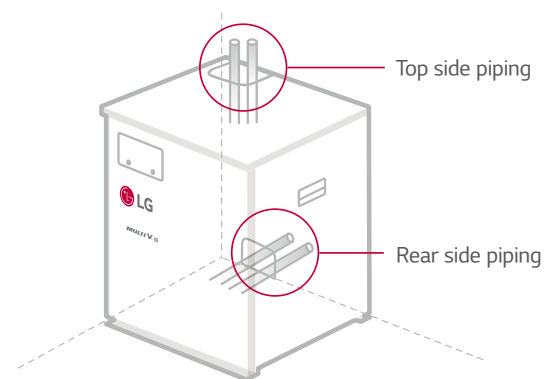

Energy Efficiency

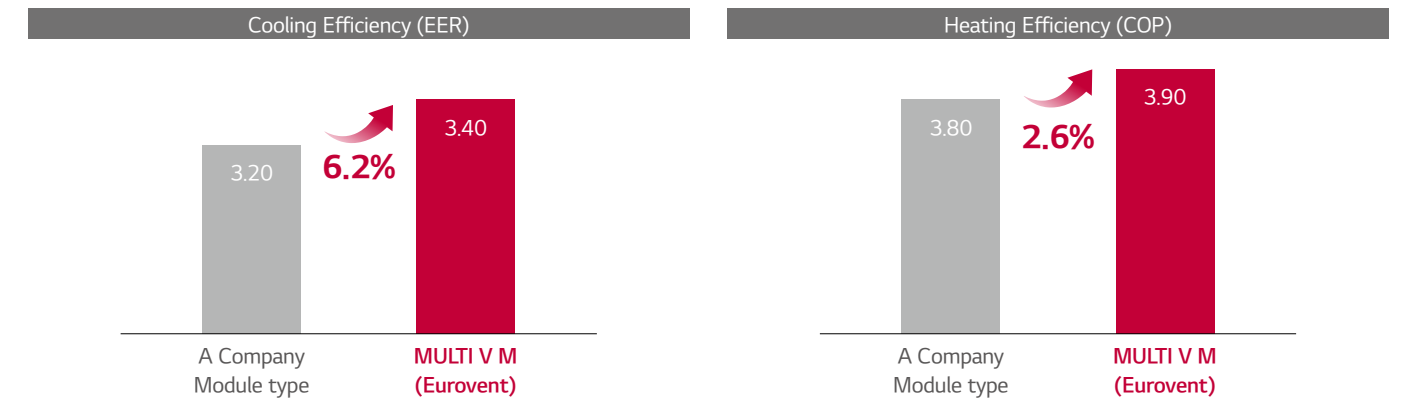

New Type Scroll

MULTI V M ensures world's best class energy efficiency with innovative technology including the LG's New Type Scroll compressor.

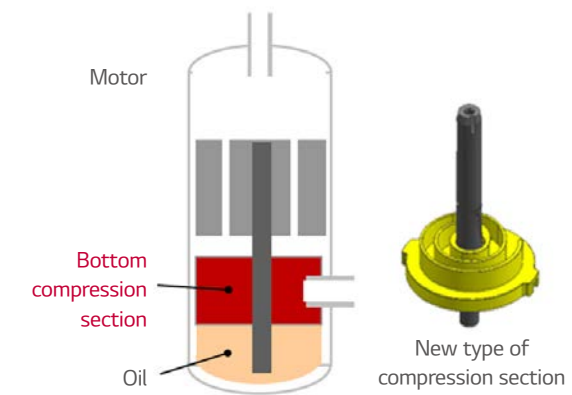

Smart Load Control

To save operation energy, automatically control the refrigerant temperature according to outside temperature.

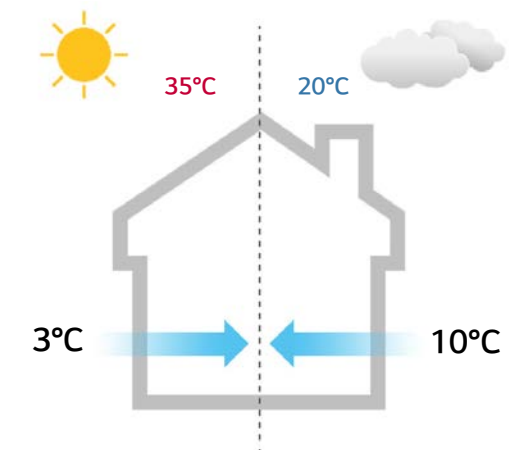

MULTI V MODULAR

Outside Unit Function

Category	Functions	Modular
Key Refrigerant components	Variable Path of Outdoor Units HEX	-
	HiPOR™ (High Pressure Oil Return)	-
	Humidity Sensor	-
	Anti Corrosion Black Fin	○
	Oil Sensor	-
Useful Function	Dual Sensing	-
	Low Noise Operation	○
	Hgh Static Mode of Outdoor Units Fan	○
	Partial Defrosting	-
	Auto Dust Cleaning of Outdoor Units (Fan reverse rotation)	-
	Indoor Cooling Comfort Mode Based Outdoor Temperature	○
	Smart Load Control (SLC) (Changing indoor discharge air temperature according to load)	○
	Outdoor Units Control Refer to Humidity	-
	Defrost / Deicing	○
	High Pressure Switch	○
Reliability	Phase Protection	○
	Restart Delay (3-minutes)	○
	Self Diagnosis	○
	Soft Start	○
	Test Run Function	-
Central Controller	AC Ez (Simple Controller)	PQCSZ250S0
	AC Ez Touch	PACEZA000
	AC Smart IV	PACS4B000
	AC Smart 5	PACSSA000
	ACP (Advanced Control Platform) IV	PACP4B000
	ACP (Advanced Control Platform) 5	PACP5A000
	AC Manager 5	PACM5A000
BNU (Building Network Unit)	ACP Lonworks	PLNWKB000
	ACP BACnet	PQNFB17C0
Installation	Refrigerant Charging Kit	-
	Variable Water Flow Valve Control Kit	-
PDI (Power Distribution Indicator)	Standard	-
	Premium	-
Cool / Heat Selector		PRDSBM
Low Ambient Kit		-
IO Module (ODU Dry Contact)		PVDSMN000
Cycle Monitoring Device	LGMV	PRCTILO
	Mobile LGMV	PLGMVW100

※ ○ : Applied, - : Not Applied

Heat Pump

Cooling

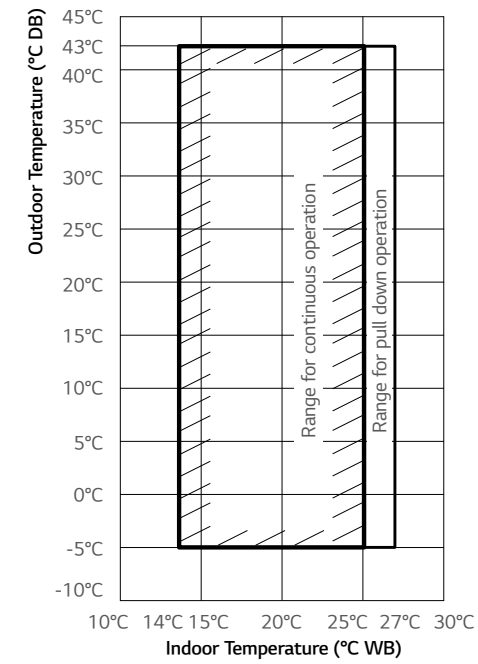

Heating

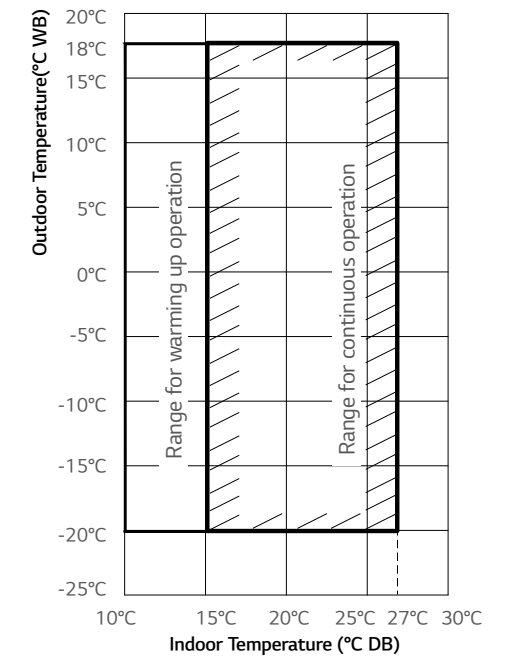

MULTI V MODULAR

Dimension

Compressor

[Unit : mm]

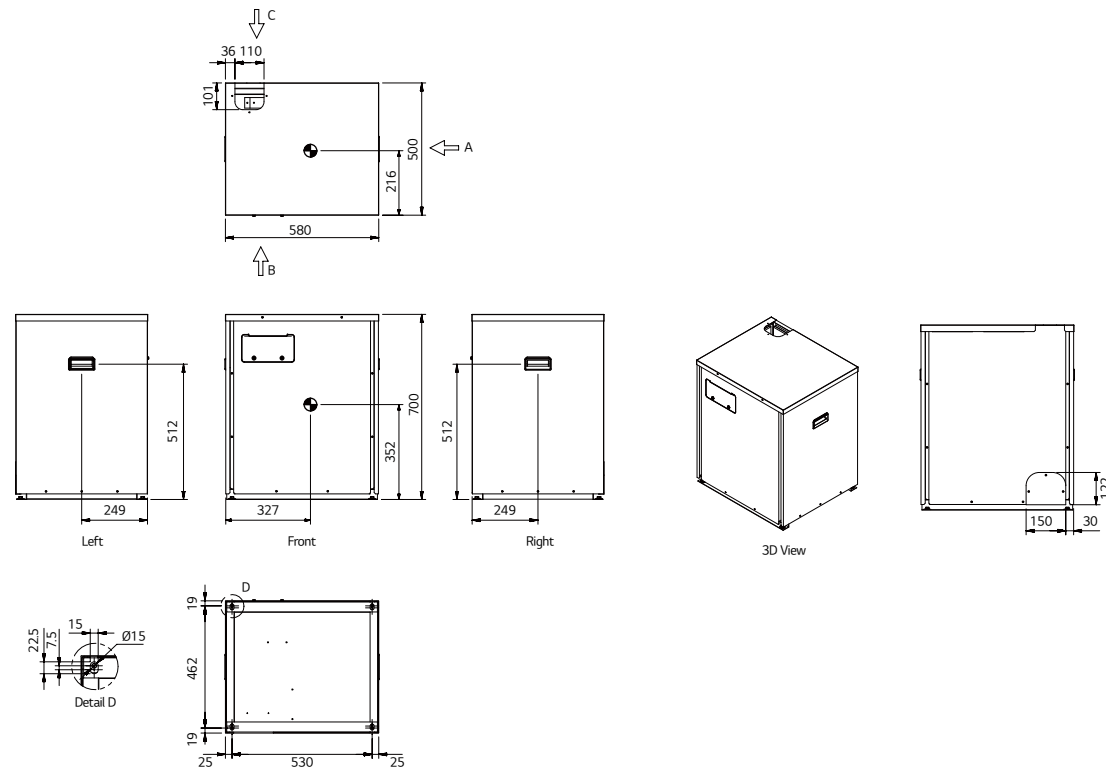

Heat Exchanger Module

[Unit : mm]

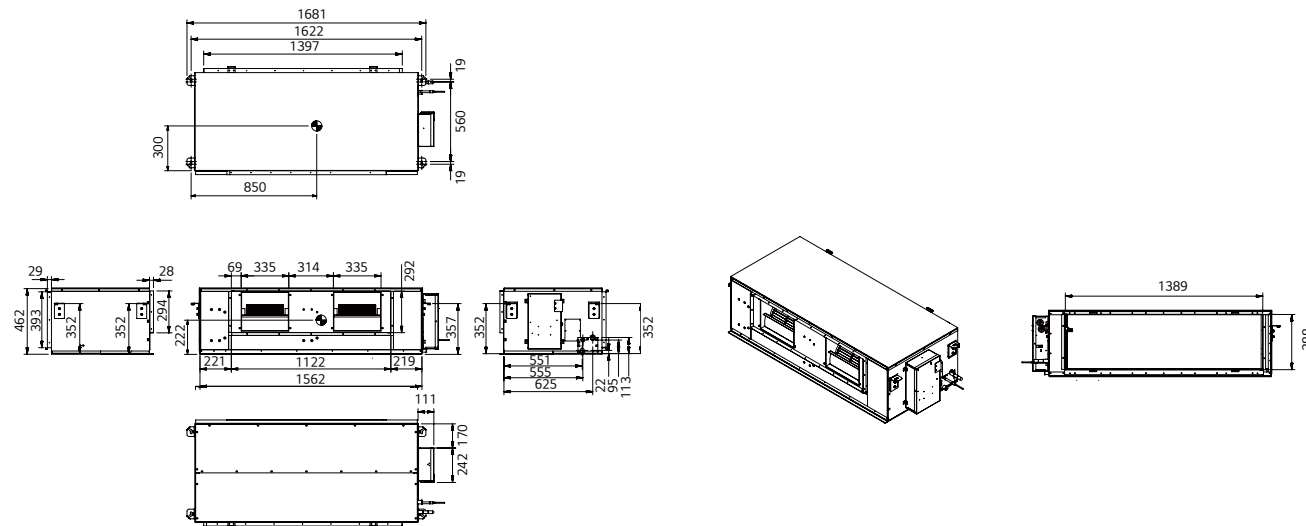

Installation Space for Compressor Module

Top View

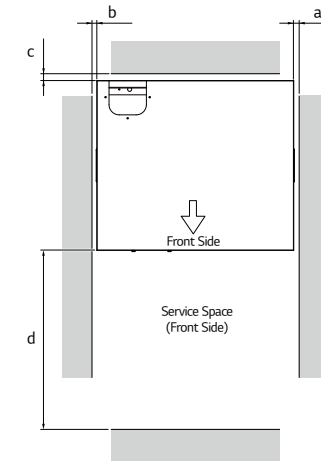

Front View

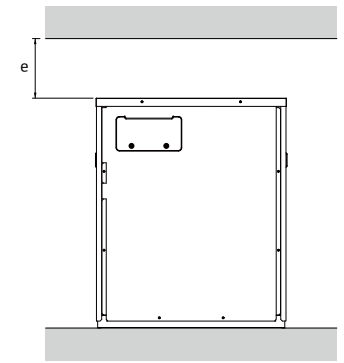

Category	Mark	Description	Installation Space (mm)
Compressor Module	a	Right	10 or More
	b	Left	10 or More
	c	Rear	10 or More
	d	Front	500 or More
	e	Top	200 or More

Installation Space for Heat exchanger Module

Top View

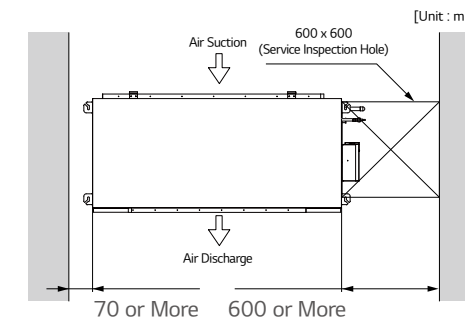

Front View

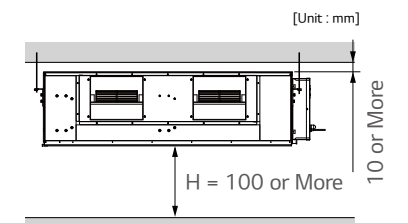

MULTI V MODULAR



※ Below spec can be revised until PDB distributed.

HP			5	
Model Name	Combination Unit		Compressor Module	
Capacity ¹⁾	Cooling (Rated)	kW	14.0	
		kcal/h	12,000	
	Heating (Rated / Max.)	kW	14.0 / 16.0	
kcal/h		12,000 / 13,800		
Input (Rated) ¹⁾	Cooling (Rated)	kW	4.12	
	Heating (Rated / Max.)	kW	3.59 / 4.32	
EER (Based on Rated capacity)			3.40	
COP (Based on Rated capacity)			3.90	
COP (Based on Max. capacity)			3.70	
Power Factor ²⁾	Rated	-	0.93	
Casing Color			Morning Gray	
Heat Exchanger			-	
Compressor	Type		Hermetic Motor Compressor	
	Piston Displacement	cm ³ /rev	31.6	
	Number of Revolution	rev/min	3,600	
	Motor Output	W	3,200	
	Starting Method		DC Inverter Starting	
	Oil Type		FVC68D(PVE)	
	Oil Charge		1,000	
Fan	Type		-	
	Motor Output x Number	W	-	
	Air Flow Rate (High)	m ³ /min	-	
		ft ³ /min	-	
	Drive		-	
External Static Pressure	Nominal (Rated, Factory Set)	mmAq(Pa)	-	
	Max.	mmAq(Pa)	-	
Pipe Connections	Liquid / Gas	mm(inch)	Ø 9.52(3/8) - IDU / Ø 15.88(5/8) - IDU	
Dimensions (W x H x D)		mm	580 x 700 x 500	
		inch	22-27/32 x 27-9/16 x 19-11/16	
Net Weight		kg	69	
		lbs	152	
Sound Pressure Level	Cooling / Heating	dB(A)	45 / 45	
	High pressure protection	-	High pressure sensor	
	Compressor / Fan	-	Over-heat protection	
Protection Devices	Inverter	-	Over-heat protection / Over-current protection	
Communication Cable	No. x mm ² (VCTF)		2C x 1.0 - 1.5	
Refrigerant	Refrigerant Name		R410A	
	Precharged Amount	kg	2.0	
		lbs	4.4	
	t-CO ₂ eq		4.2	
Control			-	
Power Supply	V, Ø, Hz		380-415, 3, 50	
Number of Maximum Connectable Indoor Units ³⁾			10	

- Note : 1. Eurovent Test Condition : Type of indoor unit connected is only Ceiling Concealed Duct.
 - Refer to EUROVENT certification programme for more detail test conditions.
 - Refer to EUROVENT website for test values connected Ceiling Cassette type indoors.
 2. Performances are based on the following conditions :
 - Cooling Temperature : Indoor 27°C (80.6°F) DB / 19°C (66.2°F) WB, Outdoor 35°C (95°F) DB / 24°C (75.2°F) WB
 - Heating Temperature : Indoor 20°C (68°F) DB / 15°C (59°F) WB, Outdoor 7°C (44.6°F) DB / 6°C (42.8°F) WB
 - Heat Exchanger Module - Compressor Module = 5m
 - Compressor Module - Indoor Unit = 7.5m
 3. The maximum combination ratio is 130%.
 4. Wiring cable size must comply with the applicable local and national codes.
 5. Due to our policy of innovation some specifications may be changed without notification.
 6. Sound Level Values are measured at Anechoic chamber. Therefore, these values can be increased owing to ambient conditions during operation.
 7. Power factor could vary less than ±1% according to the operating conditions.
 8. This product contains Fluorinated greenhouse gases. (R410A, GWP (Global warming potential) = 2087.5)



※ Below spec can be revised until PDB distributed.

HP			5	
Model Name	Combination Unit		Heat Exchanger Module	
Capacity ¹⁾	Cooling (Rated)	kW	-	
		kcal/h	-	
	Heating (Rated / Max.)	kW	- / -	
kcal/h		- / -		
Input (Rated) ¹⁾	Cooling (Rated)	kW	-	
	Heating (Rated / Max.)	kW	- / -	
EER (Based on Rated capacity)			-	
COP (Based on Rated capacity)			-	
COP (Based on Max. capacity)			-	
Power Factor ²⁾	Rated	-	-	
Casing Color			Galvanized Steel Plate	
Heat Exchanger			Ocean Black Fin (Wide Louver Plus)	
Compressor	Type		-	
	Piston Displacement	cm ³ /rev	-	
	Number of Revolution	rev/min	-	
	Motor Output	W	-	
	Starting Method		-	
	Oil Type		-	
	Oil Charge		-	
Fan	Type		Sirocco Fan	
	Motor Output x Number	W	400 x 2	
	Air Flow Rate (High)	m ³ /min	60	
		ft ³ /min	2,119	
	Drive		Direct	
External Static Pressure	Nominal (Rated, Factory Set)	mmAq(Pa)	3 (29)	
	Max.	mmAq(Pa)	16 (157)	
Pipe Connections	Liquid / Gas	mm(inch)	Ø 12.7(1/2) - Comp. Module / Ø 19.05(3/4) - Comp. Module	
Dimensions (W x H x D)		mm	1,562 x 460 x 688	
		inch	61-1/2 x 18-1/8 x 27-3/32	
Net Weight		kg	84	
		lbs	185	
Sound Pressure Level	Cooling / Heating	dB(A)	45 / 45	
	High pressure protection	-	-	
	Compressor / Fan	-	Fan driver overload protector	
Protection Devices	Inverter	-	-	
Communication Cable	No. x mm ² (VCTF)		2C x 1.0 - 1.5	
Refrigerant	Refrigerant Name		-	
	Precharged Amount	kg	-	
		lbs	-	
	t-CO ₂ eq		-	
Control			Electronic Expansion Valve	
Power Supply	V, Ø, Hz		1, 220-240, 50	
Number of Maximum Connectable Indoor Units ³⁾			-	

- Note : 1. Eurovent Test Condition : Type of indoor unit connected is only Ceiling Concealed Duct.
 - Refer to EUROVENT certification programme for more detail test conditions.
 - Refer to EUROVENT website for test values connected Ceiling Cassette type indoors.
 2. Performances are based on the following conditions :
 - Cooling Temperature : Indoor 27°C (80.6°F) DB / 19°C (66.2°F) WB, Outdoor 35°C (95°F) DB / 24°C (75.2°F) WB
 - Heating Temperature : Indoor 20°C (68°F) DB / 15°C (59°F) WB, Outdoor 7°C (44.6°F) DB / 6°C (42.8°F) WB
 - Heat Exchanger Module - Compressor Module = 5m
 - Compressor Module - Indoor Unit = 7.5m
 3. The maximum combination ratio is 130%.
 4. Wiring cable size must comply with the applicable local and national codes.
 5. Due to our policy of innovation some specifications may be changed without notification.
 6. Sound Level Values are measured at Anechoic chamber. Therefore, these values can be increased owing to ambient conditions during operation.
 7. Power factor could vary less than ±1% according to the operating conditions.
 8. This product contains Fluorinated greenhouse gases. (R410A, GWP (Global warming potential) = 2087.5)

MULTI V WATER IV

Piping Length

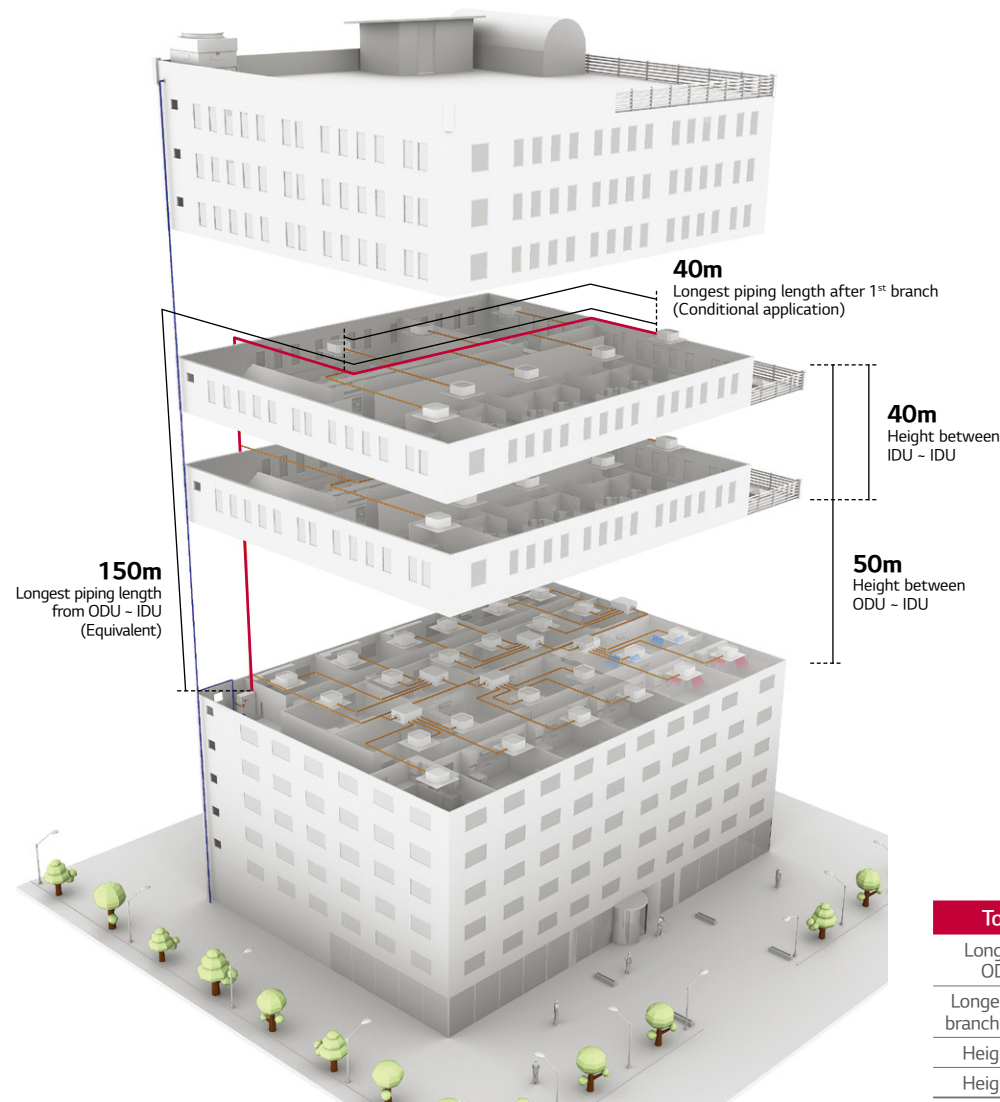

Total Piping Length	300m
Longest piping length from ODU - IDU(Equivalent)	150m (175m)
Longest piping length after 1 st branch (Conditional application)	40m (90m)
Height between ODU - IDU	50m
Height between IDU - ODU	40m

High Efficiency System Regardless of External Conditions

Regardless of outdoor temperature and other environmental conditions, MULTI V WATER IV is the optimal solution.

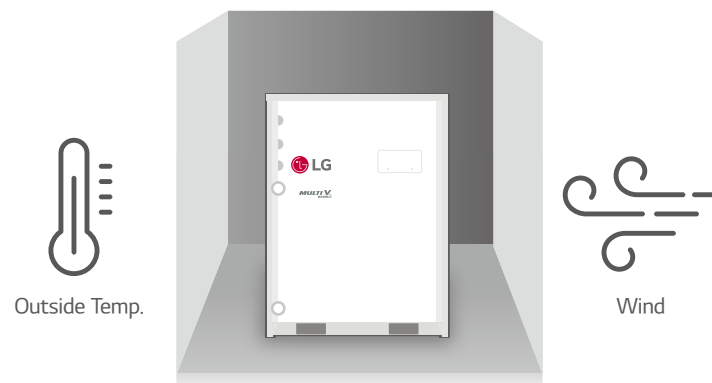

MULTI V WATER IV System for Geothermal Applications

Uses underground heat sources such as soil, ground water, lake, river, etc. as renewable energy for cooling and Heating of a building. Water or antifreeze solution is circulated through the closed loop HDPE (High Density Poly-Ethylene) pipes buried beneath the earth's surface. It is a highly efficient and eco-friendly MULTI V system.

- The Circulating water temperature range is between -5°C ~ 45°C
- Antifreeze should be applied depending on the application.

* Please contact local LG office for application availability.

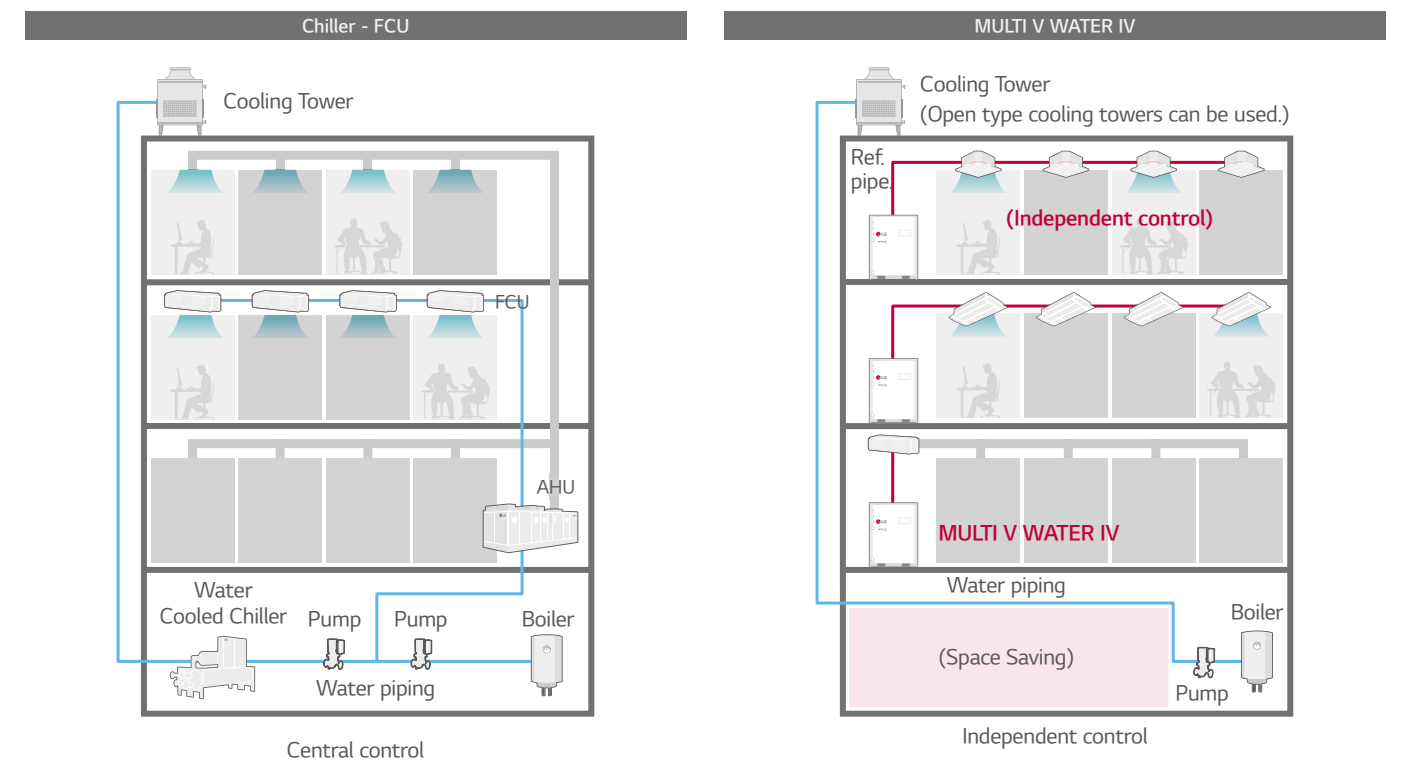
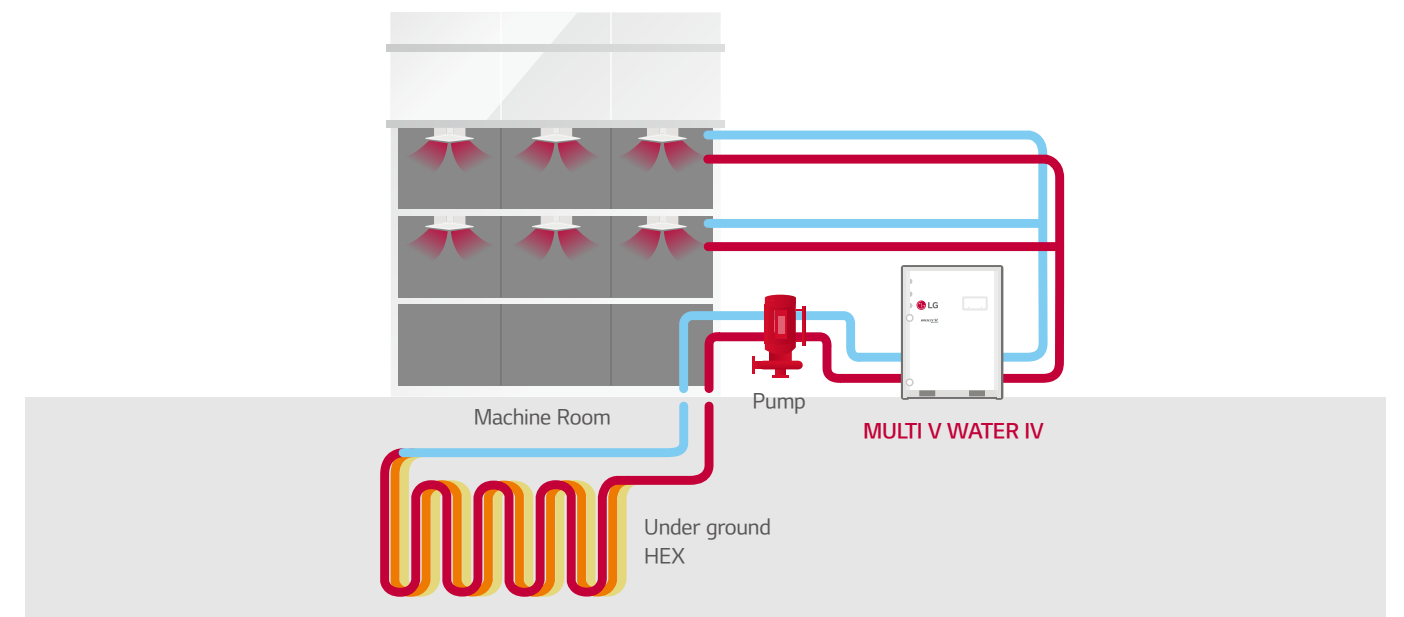

MULTI V WATER IV

Economical, Highly Efficient System

LG's key technologies are integrated to inverter compressor

Adopting a water-based cooling method, this unit optimizes performance in comparison to compressor capacity. It also ensures heat exchange performance for high-rise buildings, thus allowing electrical-savings.

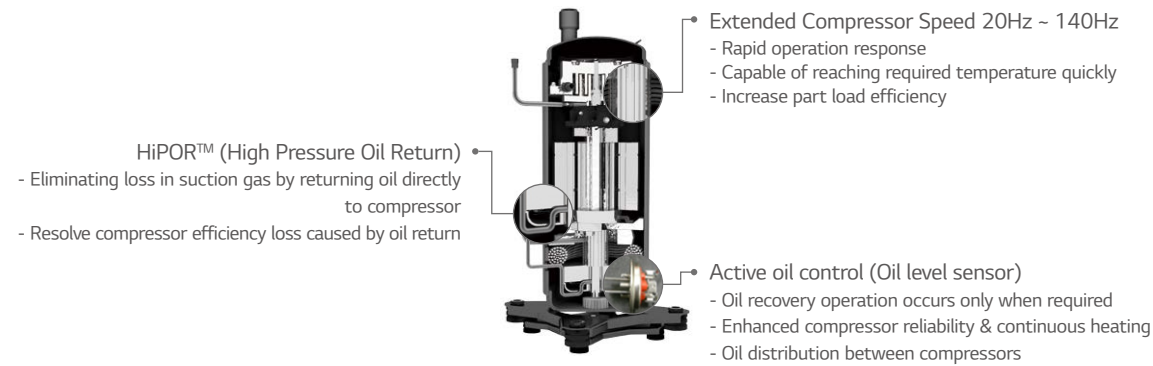

Maximum COP

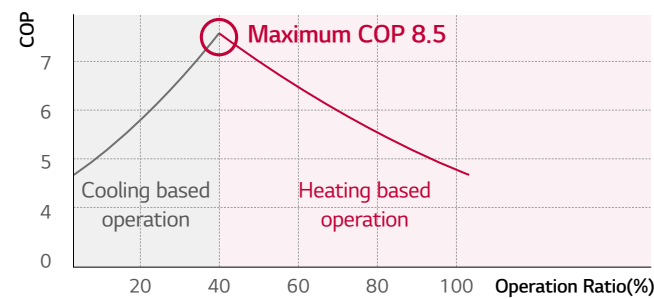

* Outside unit water inlet temperature : 7°C
 * Indoor temperature : 20°C DB / 15°C WB
 * Maximum COP Condition : Cooling 40% + Heating 60% operation

Economical, Highly Efficient System

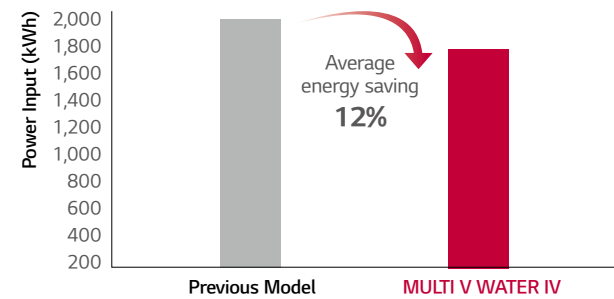

LG's 4th Generation Inverter Compressor

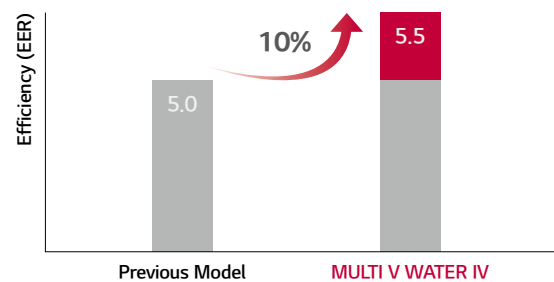

- 5% HEX Optimization
- 2% Cycle Composition Improvement
- 1% Inverter Control
- 1% Active Oil Control
- 1% HiPOR™

* Comparison between 10HP in cooling mode

Integrated Part Load Efficiency

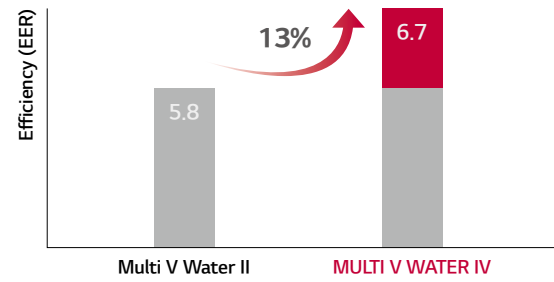

- 6% HEX Optimization
- 4% Cycle Composition Improvement
- 1% Inverter Control
- 1% Active Oil Control
- 1% HiPOR™

Variable Water Flow Control (Option)

Supporting your buildings to become greener

The world's first variable water flow control system for water cooled VRF system. LG applied Variable Water Flow Control to optimise water flow control regarding partial cooling or heating load conditions. Because of this it's also possible to reduce circulation pump energy consumption.

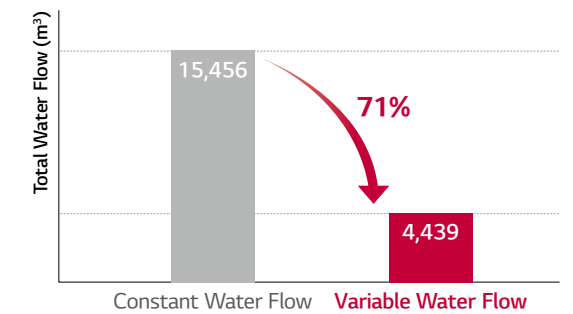
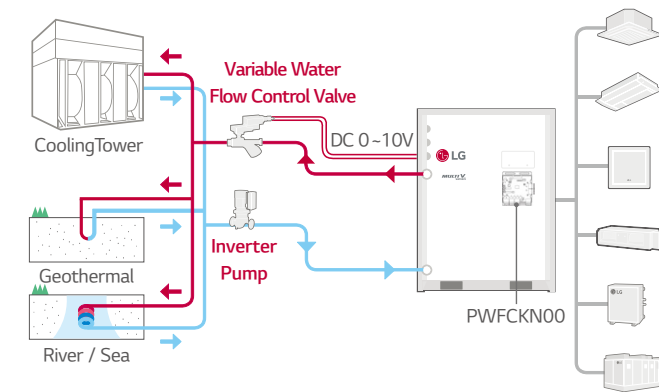

Note : 1. Location: Paris, France
 2. Office, 68,000m²
 3. Operation time: 1,344 hours (cooling period)

Project Example : 63F (Pump : 20,064 LPM, 42.4mAq * 4ea)

- 1) Inverter pump with Multi V Water and variable water flow control kit
- 2) Constant pump (Step control) with Water cooled VRF

10 years energy cost (\$)

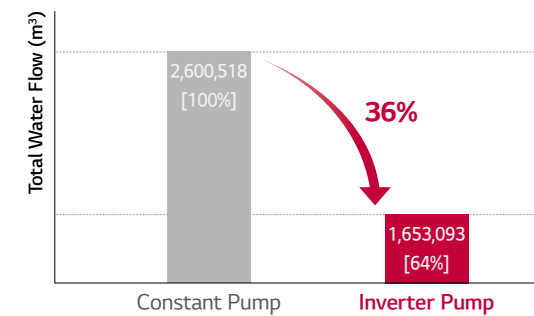

Unit	5 years		10 years	
	Energy Use (kWh)	Pump Running Cost (\$)	Energy Use (kWh)	Pump Running Cost (\$)
Constant pump	7,952,040	1,142,441	15,904,080	2,600,518
Inverter pump	5,054,940	726,225	10,109,880	1,653,093

- Power consumption rate : 0.13\$/kWh
- Annual power consumption rate expected to increase by 5%

Largest Capacity

World's largest capacity makes it easy to apply to large building and large systems.

Providing 8-20HP(22.4-56kW) with single unit, and up to the world's largest capacity 80HP(224kW) by combination.

HP	8	10	14	20	22	24	28	30	34	40	42 ~ 60	62 ~ 80
kW	22.4	28	39.2	56	61.6	67.2	78.4	84	95.2	112	117.6-168	173.6-224
LG	1 Unit				2 Units				3 Units		4 Units	

MULTI V WATER IV

Longest Piping Length

Sufficient pipes length limitation in Design and Installation of immense variety of building

Provide flexible installation up to 300m of total piping length. As water pipes are not connected to indoor units, users are free from water leakage problems.

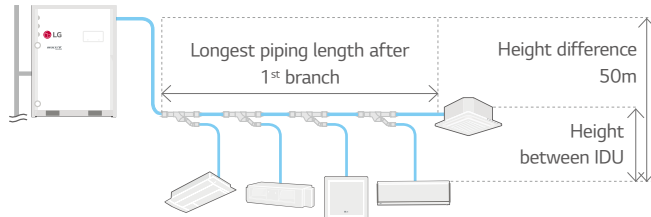

Total piping length	300m
Actual longest piping length (Equivalent)	150m (175m)
Longest piping length after 1 st branch (Conditional application)	40m (90m)
Height difference between ODU - IDU	50m
Height difference between IDU - IDU	40m

Compact Size

Significant uptake of construction space that can be used for commercial use or public space as much as possible.

The optimal design of the compact, lightweight outdoor unit enables double stacking, which results in 50% savings in installation space.

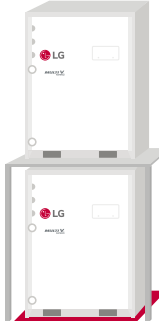
Company B	MULTI V WATER IV
 <p>28kw x 4EA Per Each 880 x 550 mm</p>	 <div style="border: 1px solid black; border-radius: 50%; width: 30px; height: 30px; display: flex; align-items: center; justify-content: center; margin: 0 auto;"> 61% Reduced </div> <p>56kw x 2EA Per Each 755 x 500 mm</p>

* 112kw, Floor area based

Light Weight

Nothing or Decrease additional load reinforcement work at building

Easier to transport and install thanks to 15% reduction in overall weight.

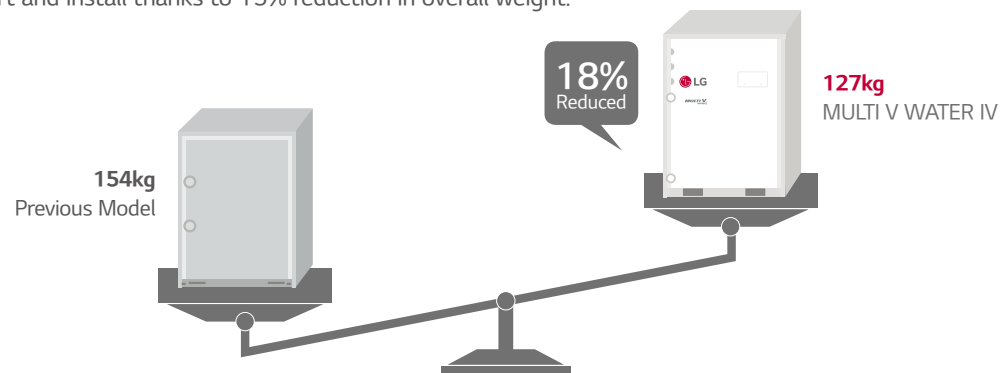

* Based on 28kw

Outside Unit Function

Category	Functions	MULTI V WATER IV	
Key Refrigerant components	Variable Path of Outdoor Units HEX	-	
	HiPOR™ (High Pressure Oil Return)	○	
	Humidity Sensor	-	
	Anti Corrosion Black Fin	-	
	Oil Sensor	○	
Useful Function	Dual Sensing	-	
	Low Noise Operation	-	
	Hgh Static Mode of Outdoor Units Fan	-	
	Partial Defrosting	-	
	Auto Dust Cleaning of Outdoor Units (Fan reverse rotation)	-	
	Indoor Cooling Comfort Mode Based Outdoor Temperature	-	
	Smart Load Control (SLC) (Changing indoor discharge air temperature according to load)	-	
	Outdoor Units Control Refer to Humidity	-	
	Defrost / Deicing	-	
	High Pressure Switch	○	
Reliability	Phase Protection	○	
	Restart Delay (3-minutes)	○	
	Self Diagnosis	○	
	Soft Start	○	
	Test Run Function	○	
	Central Controller	AC Ez (Simple Controller)	PQCSZ250S0
		AC Ez Touch	PACEZA000
AC Smart IV		PACS4B000	
AC Smart 5		PAC55A000	
ACP (Advanced Control Platform) IV		PQCPC22A0	
ACP (Advanced Control Platform) 5		PACP5A000	
AC Manager 5		PACM5A000	
BNU (Building Network Unit)	ACP Lonworks	PLNWKB000	
	ACP BACnet	PQNF817C0	
Installation	Refrigerant Charging Kit	-	
	Variable Water Flow Valve Control Kit	PWFCKN000	
PDI (Power Distribution Indicator)	Standard	PPWRDB000	
	Premium	PQNUD1S40	
Cool / Heat Selector		PRDSBM	
Low Ambient Kit		-	
IO Module (ODU Dry Contact)		PVDSMN000	
Cycle Monitoring Device	LGMV	PRCTILO	
	Mobile LGMV	PLGMWW100	

※ ○ : Applied, - : Not Applied

MULTI V WATER IV

Operation Limits

Cooling

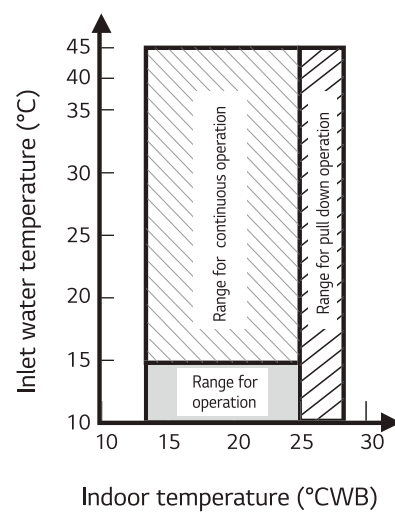

Heating

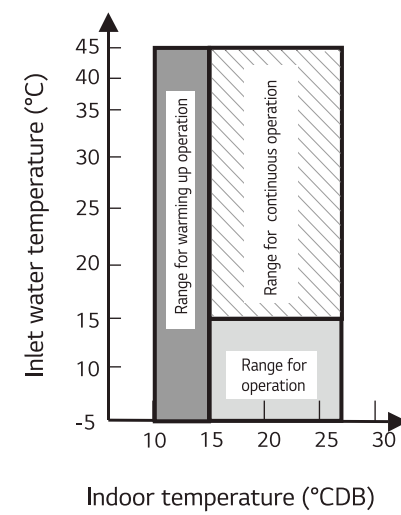

Note : 1. These figures assume the following operating conditions:
 2. Equivalent piping length:7.5m
 3. Level difference:0m

Optional Accessories

No.	Name	Model
1	Y branch pipe	ARBLN01621
		ARBLN03321
		ARBLN07121
		ARBLN14521
		ARBLN23220
2	Header	ARBL054
		ARBL057
		ARBL104
		ARBL107
		ARBL1010
		ARBL2010
3	Connection pipe of Outdoor Units	ARCNN21
		ARCNN31
		ARCNN41

Multi V Water IV heating dissipation value by model

Model	HP	Heating Dissipation Value		
ARWN080LAS4	8	600 W	515.9 kcal/h	0.143 kcal/s
ARWN100LAS4	10	630 W	541.7 kcal/h	0.150 kcal/s
ARWN120LAS4	12	660 W	567.5 kcal/h	0.158 kcal/s
ARWN140LAS4	14	690 W	593.3 kcal/h	0.165 kcal/s
ARWN160LAS4	16	700 W	601.9 kcal/h	0.167 kcal/s
ARWN180LAS4	18	720 W	619.1 kcal/h	0.172 kcal/s
ARWN200LAS4	20	750 W	644.9 kcal/h	0.179 kcal/s

[Test condition]
 1) Indoor air temperature : DB 40°C, WB : 32°C
 Note : A design stage should be considered to ventilation system in mechanical room.

Dimension

ARWN080LAS4 / ARWN100LAS4 / ARWN140LAS4 / ARWN200LAS4

[Unit : mm]

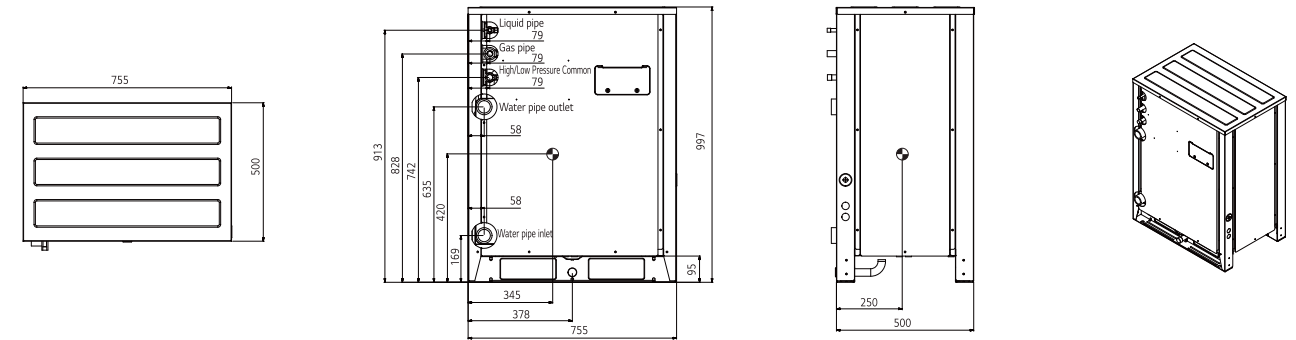

Individual Installation

▨: Service area

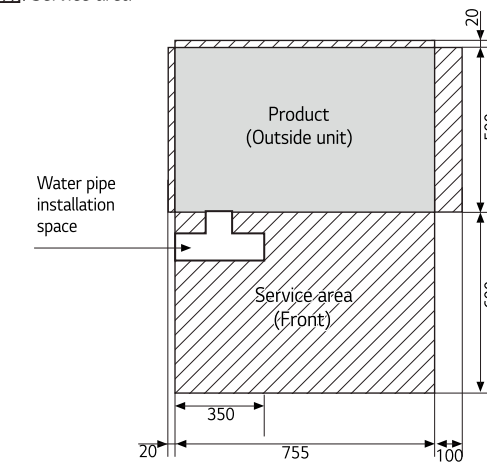

Water Piping Installation

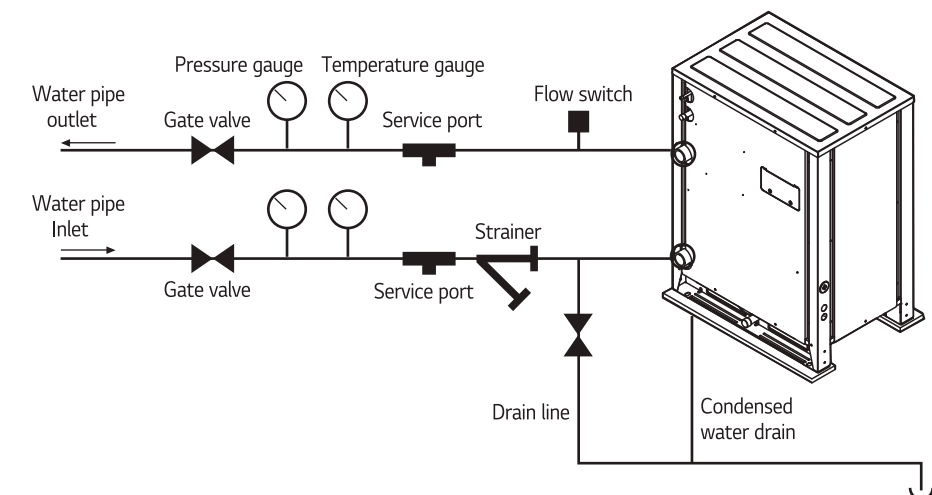

Precaution of Installation

1. Do not install the unit at the outdoors. (Otherwise it may cause fire, electric shock and trouble.) Recommended ambient temperature of outdoor unit is between 0–40°C
2. Keep the water temperature between **10–45°C**. Other it may cause the breakdown. Standard water supply temperature is 30°C for Cooling and 20°C for heating.
3. Establish an **anti-freeze plan** for the water supply when the product is stopped during the winter.
4. Be careful of the **water purity control**. Otherwise it may cause the breakdown due to water pipe corrosion. (Refer to 'Standard Table for Water Purity Control')
5. The water pressure resistance of the water pipe system of this product is **1.98MPa**
6. Always install a **trap** so that the drained water does not back flush
7. Install a **pressure gauge and temperature gauge** at the inlet and outlet of the water pipe.
8. **Flexible joints** must be installed not to cause any leakage from the vibration of pipes.
9. Install a **service port** to clean the heat exchanger at the each end of the water inlet and outlet.
10. It is recommended to install the **flow switch** to the water collection pipe system connecting to the outdoor unit. (Flow switch acts as the 1st protection device when the heat water is not supplied.)
11. When setting the flow switch, it is recommended to use the product with default set value to satisfy the minimum flow rate of this product. (The minimum flow rate range of this product is **50%**.)
12. To protect the water cooling type product, you must install a **strainer with 50 mesh** or more on the heat water supply pipe. If not installed, it can result in damage of heat exchanger by the following situation.
 - 1) Heat water supply within the plate type heat exchanger is composed of multiple small paths.
 - 2) If you do not use a strainer with 50 mesh or more, alien particles can partially block the water paths.
 - 3) When running the heater, the plate type heat exchanger plays the role of the evaporator, and at this time, the temperature of the refrigerant side drops to drop the temperature of the heat water supply, which can result in icing point in the water paths.
 - 4) And as the heating process progresses, the water paths can be partially frozen to lead to damage in plate type heat exchanger.
 - 5) As a result of the damage of the heat exchanger from the freezing, the refrigerant side and the heat water source side will be mixed to make the product unusable.

Bouygues Challenger

LG MULTI V Water Solution with Geothermal Application



Site Information

The industrial group Bouygues was established in France in 1952. It now maintains operations in 80 countries and employs more than 131,000 people. In 1988, after two years of construction, the new headquarters for Bouygues Construction was officially opened for business. Named Challenger, the complex became a technological showcase for late 20th century architecture.

LG Solution

Bouygues decided to convert their headquarters into an eco-friendly building by significantly reducing its energy footprint. The LG MULTI V Water system was chosen as the ideal HVAC solution for this project. The system not only saves energy but also reduces water usage as it recycles water in order to regulate the temperature of the building. With LG's advanced technology, the building's water consumption was reduced by more than 70 percent.

MULTI V WATER IV

HEAT PUMP

ARWN080LAS4 / ARWN100LAS4 / ARWN140LAS4 / ARWN200LAS4



HP		8	10	14	20	
Model Name	Combination Unit	ARWN080LAS4	ARWN100LAS4	ARWN140LAS4	ARWN200LAS4	
	Independent Unit	ARWN080LAS4	ARWN100LAS4	ARWN140LAS4	ARWN200LAS4	
Capacity	Cooling	kW	22.4	28.0	39.2	56.0
	Heating	kW	25.2	31.5	44.1	63.0
Input	Cooling	kW	3.86	5.09	7.84	11.20
	Heating	kW	4.20	5.34	8.17	11.67
Casing Color		Warm Gray , Mornig Gray	Warm Gray , Mornig Gray	Warm Gray , Mornig Gray	Warm Gray , Mornig Gray	
Compressor	Type	Hermetically Sealed Scroll	Hermetically Sealed Scroll	Hermetically Sealed Scroll	Hermetically Sealed Scroll	
	Combination	(Inverter) x 1	(Inverter) x 1	(Inverter) x 1	(Inverter) x 1	
	Piston Displacement	cm ³ /rev	43.8	43.8	43.8	62.1
	Number of revolution	rev/min	Inverter 3,600 at 60Hz	Inverter 3,600 at 60Hz	Inverter 3,600 at 60Hz	Inverter 3,600 at 60Hz
	Motor Output	kW	4.2	4.2	4.2	5.3
	Starting Method		Direct On Line	Direct On Line	Direct On Line	Direct On Line
	Oil Type		FVC68D(PVE)	FVC68D(PVE)	FVC68D(PVE)	FVC68D(PVE)
	Oil Charge Amount	cc	1 200 + 1 600	1 200 + 1 600	1 200 + 1 600	1 400 + 1 600
Heat Exchanger	Type	Stainless Steel Plate	Stainless Steel Plate	Stainless Steel Plate	Stainless Steel Plate	
	Maximum Pressure Resistance	kgf/cm ²	45	45	45	
	Head Loss	kPa	10.7	15.8	28.6	30.1
	Rated Water Flow	LPM	77	96	135	192
Temp. range of	Cooling	10°C - 45°C(50°F - 113°F)	10°C - 45°C(50°F - 113°F)	10°C - 45°C(50°F - 113°F)	10°C - 45°C(50°F - 113°F)	
Circulation water	Heating	-5°C - 45°C(23°F - 113°F)	-5°C - 45°C(23°F - 113°F)	5°C - 45°C(23°F - 113°F)	-5°C - 45°C(23°F - 113°F)	
Refrigerant Connecting Pipes	Liquid Pipes	mm(inch)	9.52(3/8)	9.52(3/8)	12.7(1/2)	12.7(1/2)
	Gas Pipes	mm(inch)	22.2(7/8)	22.2(7/8)	25.4(1)	28.58(1-1/8)
Water Connecting Pipes	Inlet	mm	PT40 (1-1/2, Internal)	PT40 (1-1/2, Internal)	PT40 (1-1/2, Internal)	PT40 (1-1/2, Internal)
	Outlet	mm	PT40 (1-1/2, Internal)	PT40 (1-1/2, Internal)	PT40 (1-1/2, Internal)	PT40 (1-1/2, Internal)
	Drain Outlet	mm	PT20 (3/4, External)	PT20 (3/4, External)	PT20 (3/4, External)	PT20 (3/4, External)
Dimensions (W x H x D)	mm	(755 x 500 x 997) x 1	(755 x 500 x 997) x 1	(755 x 500 x 997) x 1	(755 x 500 x 997) x 1	
	inch	(29-23/32 x 39-1/4 x 19-11/16) x 1	(29-23/32 x 39-1/4 x 19-11/16) x 1	(29-23/32 x 39-1/4 x 19-11/16) x 1	(29-23/32 x 39-1/4 x 19-11/16) x 1	
Net Weight	kg	127 x 1	127 x 1	127 x 1	140 x 1	
	lbs	280 x 1	280 x 1	280 x 1	309 x 1	
Transmission Cable (CVV-SB)	mm ²	1.0 -1.5 x 2C	1.0 -1.5 x 2C	1.0 -1.5 x 2C	1.0 -1.5 x 2C	
Refrigerant	Name		R410A	R410A	R410A	
	Charge Amount	kg	5.8	5.8	5.8	3.0
	Control Device		EEV	EEV	EEV	EEV
Power Supply		∅ / V / Hz	3 / 380 - 415 / 50	3 / 380 - 415 / 50	3 / 380 - 415 / 50	3 / 380 - 415 / 50
			3 / 380 / 60	3 / 380 / 60	3 / 380 / 60	3 / 380 / 60
Sound Pressure Level	Cooling	dB(A)	47	50	58	54
	Heating	dB(A)	51	53	57	60
Sound Power Level	Cooling	dB(A)	59	62	70	66
	Heating	dB(A)	63	65	69	72

* This product contains Fluorinated Greenhouse Gases. (R410A)
 Note : 1. Capacities and Inputs are based on the following conditions
 - Cooling : Indoor temp. 27°C (80.6°F) DB / 19°C (66.2°F) WB, Water inlet temp. 30°C (86°F), Interconnecting piping length 7.5m, Level difference of zero
 - Heating : Indoor temp. 20°C (68°F) DB, Water inlet temp. 20°C (68°F)
 2. Capacities are net capacities
 3. Due to our policy of innovation some specifications may be changed without notification
 4. Add an anti freeze to circulation water when outside unit is operating under 10°C (50°F), and change the DIP switch on main PCB. (For more information on installation section.)

HEAT PUMP

ARWN220LAS4 / ARWN240LAS4 / ARWN280LAS4 / ARWN300LAS4



HP		22	24	28	30	
Model Name	Combination Unit	ARWN220LAS4	ARWN240LAS4	ARWN280LAS4	ARWN300LAS4	
	Independent Unit	ARWN140LAS4 ARWN080LAS4	ARWN140LAS4 ARWN100LAS4	ARWN140LAS4 ARWN140LAS4	ARWN200LAS4 ARWN100LAS4	
Capacity	Cooling	kW	61.6	67.2	78.4	84.0
	Heating	kW	69.3	75.6	88.2	94.5
Input	Cooling	kW	11.70	12.93	15.68	16.29
	Heating	kW	12.37	13.51	16.34	17.01
Casing Color		Warm Gray , Mornig Gray	Warm Gray , Mornig Gray	Warm Gray , Mornig Gray	Warm Gray , Mornig Gray	
Compressor	Type	Hermetically Sealed Scroll	Hermetically Sealed Scroll	Hermetically Sealed Scroll	Hermetically Sealed Scroll	
	Combination	(Inverter) x 2	(Inverter) x 2	(Inverter) x 2	(Inverter) x 2	
	Piston Displacement	cm ³ /rev	43.8 + 43.8	43.8 + 43.8	43.8 + 43.8	62.1 + 43.8
	Number of revolution	rev/min	Inverter 3,600 at 60Hz	Inverter 3,600 at 60Hz	Inverter 3,600 at 60Hz	Inverter 3,600 at 60Hz
	Motor Output	kW	4.2+4.2	4.2 + 4.2	4.2 + 4.2	5.3 + 4.2
	Starting Method		Direct On Line	Direct On Line	Direct On Line	Direct On Line
	Oil Type		FVC68D(PVE)	FVC68D(PVE)	FVC68D(PVE)	FVC68D(PVE)
	Oil Charge Amount	cc	(1 200 + 1 600) x 2	(1 200 + 1 600) x 2	(1 200 + 1 600) x 2	(1 400 + 1 200) + 1 600 x 2
Heat Exchanger	Type	Stainless Steel Plate	Stainless Steel Plate	Stainless Steel Plate	Stainless Steel Plate	
	Maximum Pressure Resistance	kgf/cm ²	45	45	45	
	Head Loss	kPa	28.6 + 10.7	28.6 + 15.8	28.6 + 28.6	30.1 + 15.8
	Rated Water Flow	LPM	135 + 77	135 + 96	135 + 135	192 + 96
Temp. range of	Cooling	10°C - 45°C(50°F - 113°F)	10°C - 45°C(50°F - 113°F)	10°C - 45°C(50°F - 113°F)	10°C - 45°C(50°F - 113°F)	
Circulation water	Heating	-5°C - 45°C(23°F - 113°F)	-5°C - 45°C(23°F - 113°F)	-5°C - 45°C(23°F - 113°F)	-5°C - 45°C(23°F - 113°F)	
Refrigerant Connecting Pipes	Liquid Pipes	mm(inch)	19.05(3/4)	19.05(3/4)	19.05(3/4)	19.05(3/4)
	Gas Pipes	mm(inch)	34.9(1-3/8)	34.9(1-3/8)	34.9(1-3/8)	34.9(1-3/8)
Water Connecting Pipes	Inlet	mm	PT40 + PT40 (Internal)	PT40 + PT40 (Internal)	PT40 + PT40 (Internal)	PT40 + PT40 (Internal)
	Outlet	mm	PT40 + PT40 (Internal)	PT40 + PT40 (Internal)	PT40 + PT40 (Internal)	PT40 + PT40 (Internal)
	Drain Outlet	mm	PT20 (3/4, External)	PT20 (3/4, External)	PT20 (3/4, External)	PT20 (3/4, External)
Dimensions (W x H x D)	mm	(755 x 997 x 500) x 2	(755 x 997 x 500) x 2	(755 x 997 x 500) x 2	(755 x 997 x 500) x 2	
	inch	(29-23/32 x 39-1/4 x 19-11/16) x 2	(29-23/32 x 39-1/4 x 19-11/16) x 2	(29-23/32 x 39-1/4 x 19-11/16) x 2	(29-23/32 x 39-1/4 x 19-11/16) x 2	
Net Weight	kg	127 x 2	127 x 2	127 x 2	(140 x 1) + (127 x 1)	
	lbs	280 x 2	280 x 2	280 x 2	(309 x 1) + (280 x 1)	
Transmission Cable (CVV-SB)	mm ²	1.0 -1.5 x 2C	1.0 -1.5 x 2C	1.0 -1.5 x 2C	1.0 -1.5 x 2C	
Refrigerant	Name		R410A	R410A	R410A	
	Charge Amount	kg	5.8 + 5.8	5.8 + 5.8	5.8 + 5.8	3.0 + 5.8
	Control Device		EEV	EEV	EEV	EEV
Power Supply		∅ / V / Hz	3 / 380 - 415 / 50	3 / 380 - 415 / 50	3 / 380 - 415 / 50	3 / 380 - 415 / 50
			3 / 380 / 60	3 / 380 / 60	3 / 380 / 60	3 / 380 / 60
Sound Pressure Level	Cooling	dB(A)	58	59	59	55
	Heating	dB(A)	58	58	58	61
Sound Power Level	Cooling	dB(A)	71	72	72	68
	Heating	dB(A)	71	71	71	74

* This product contains Fluorinated Greenhouse Gases. (R410A)
 Note : 1. Capacities and Inputs are based on the following conditions
 - Cooling : Indoor temp. 27°C (80.6°F) DB / 19°C (66.2°F) WB, Water inlet temp. 30°C (86°F), Interconnecting piping length 7.5m, Level difference of zero
 - Heating : Indoor temp. 20°C (68°F) DB, Water inlet temp. 20°C (68°F)
 2. Capacities are net capacities
 3. Due to our policy of innovation some specifications may be changed without notification
 4. Add an anti freeze to circulation water when outside unit is operating under 10°C (50°F), and change the DIP switch on main PCB. (For more information on installation section.)

MULTI V WATER IV

HEAT PUMP

ARWN340LAS4 / ARWN400LAS4 / ARWN420LAS4 / ARWN440LAS4



HP			34	40	42	44
Model Name	Combination Unit		ARWN340LAS4	ARWN400LAS4	ARWN420LAS4	ARWN440LAS4
	Independent Unit		ARWN200LAS4 ARWN140LAS4	ARWN200LAS4 ARWN200LAS4	ARWN200LAS4 ARWN140LAS4 ARWN080LAS4	ARWN200LAS4 ARWN140LAS4 ARWN100LAS4
Capacity	Cooling	kW	95.2	112.0	117.6	123.2
	Heating	kW	107.1	126.0	132.3	138.6
Input	Cooling	kW	19.04	22.40	22.90	24.13
	Heating	kW	19.84	23.34	24.04	25.18
Casing Color			Warm Gray , Mornig Gray	Warm Gray , Mornig Gray	Warm Gray , Mornig Gray	Warm Gray , Mornig Gray
Compressor	Type		Hermetically Sealed Scroll	Hermetically Sealed Scroll	Hermetically Sealed Scroll	Hermetically Sealed Scroll
	Combination		(Inverter) x 2	(Inverter) x 2	(Inverter) x 3	(Inverter) x 3
	Piston Displacement	cm ³ /rev	43.8 + 62.1	62.1 + 62.1	62.1 + 43.8 + 43.8	62.1 + 43.8 + 43.8
	Number of revolution	rev/min	Inverter 3,600 at 60Hz	Inverter 3,600 at 60Hz	Inverter 3,600 at 60Hz	Inverter 3,600 at 60Hz
	Motor Output	kW	4.2 + 5.3	5.3 + 5.3	5.3 + 4.2 + 4.2	5.3 + 4.2 + 4.2
	Starting Method		Direct On Line	Direct On Line	Direct On Line	Direct On Line
	Oil Type		FVC68D(PVE)	FVC68D(PVE)	FVC68D(PVE)	FVC68D(PVE)
	Oil Charge Amount	cc	(1 400 + 1 200) + 1 600 x 2	(1 400 + 1 600) x 2	(1 400 + 1 200 + 1 200) + 1 600 x 3	(1 400 + 1 200 + 1 200) + 1 600 x 3
Heat Exchanger	Type		Stainless Steel Plate	Stainless Steel Plate	Stainless Steel Plate	Stainless Steel Plate
	Maximum Pressure Resistance	kgf/cm ²	45	45	45	45
	Head Loss	kPa	30.1 + 28.6	30.1 + 30.1	30.1 + 28.6 + 10.7	30.1 + 28.6 + 15.8
	Rated Water Flow	LPM	192 + 135	192 + 192	192 + 135 + 77	192 + 135 + 96
Temp. range of Circulation water	Cooling		10°C - 45°C(50°F - 113°F)	10°C - 45°C(50°F - 113°F)	10°C - 45°C(50°F - 113°F)	10°C - 45°C(50°F - 113°F)
	Heating		-5°C - 45°C(23°F - 113°F)	-5°C - 45°C(23°F - 113°F)	-5°C - 45°C(23°F - 113°F)	-5°C - 45°C(23°F - 113°F)
Refrigerant Connecting Pipes	Liquid Pipes	mm (inch)	19.05(3/4)	19.05(3/4)	19.05(3/4)	19.05(3/4)
	Gas Pipes	mm (inch)	34.9(1-3/8)	41.3(1-5/8)	41.3(1-5/8)	41.3(1-5/8)
Water Connecting Pipes	Inlet	mm	PT40 + PT40 (Internal)	PT40 + PT40 (Internal)	PT40 + PT40 + PT40 (Internal)	PT40 + PT40 + PT40 (Internal)
	Outlet	mm	PT40 + PT40 (Internal)	PT40 + PT40 (Internal)	PT40 + PT40 + PT40 (Internal)	PT40 + PT40 + PT40 (Internal)
	Drain Outlet	mm	PT20 (3/4, External)	PT20 (3/4, External)	PT20 (3/4, External)	PT20 (3/4, External)
Dimensions (W x H x D)	mm		(755 x 997 x 500) x 2	(755 x 997 x 500) x 2	(755 x 997 x 500) x 3	(755 x 997 x 500) x 3
	inch		(29-23/32 x 39-1/4 x 19-11/16) x 2	(29-23/32 x 39-1/4 x 19-11/16) x 2	(29-23/32 x 39-1/4 x 19-11/16) x 3	(29-23/32 x 39-1/4 x 19-11/16) x 3
Net Weight	kg		(140 x 1) + (127 x 1)	140 x 2	(140 x 1) + (127 X 2)	(140 x 1) + (127 X 2)
	lbs		(309 x 1) + (280 x 1)	309 x 2	(309 x 1) + (280 X 2)	(309 x 1) + (280 X 2)
Transmission Cable (CVV-SB)	mm ²		1.0 - 1.5 x 2C	1.0 - 1.5 x 2C	1.0 - 1.5 x 2C	1.0 - 1.5 x 2C
Refrigerant	Name		R410A	R410A	R410A	R410A
	Charge Amount	kg	3.0 + 5.8	3.0 + 3.0	3.0 + 5.8 + 5.8	3.0 + 5.8 + 5.8
	Control Device		EEV	EEV	EEV	EEV
Power Supply		∅ / V / Hz	3 / 380 - 415 / 50	3 / 380 - 415 / 50	3 / 380 - 415 / 50	3 / 380 - 415 / 50
			3 / 380 / 60	3 / 380 / 60	3 / 380 / 60	3 / 380 / 60
Sound Pressure Level	Cooling	dB(A)	59	55	60	60
	Heating	dB(A)	61	61	62	62
Sound Power Level	Cooling	dB(A)	72	68	73	74
	Heating	dB(A)	74	74	76	76

* This product contains Fluorinated Greenhouse Gases. (R410A)
 Note : 1. Capacities and Inputs are based on the following conditions
 - Cooling : Indoor temp. 27°C (80.6°F) DB / 19°C (66.2°F) WB, Water inlet temp. 30°C (86°F), Interconnecting piping length 7.5m, Level difference of zero
 - Heating : Indoor temp. 20°C (68°F) DB, Water inlet temp. 20°C (68°F)
 2. Capacities are net capacities
 3. Due to our policy of innovation some specifications may be changed without notification
 4. Add an anti freeze to circulation water when outside unit is operating under 10°C (50°F), and change the DIP switch on main PCB. (For more information on installation section.)

HEAT PUMP

ARWN480LAS4 / ARWN500LAS4 / ARWN540LAS4 / ARWN600LAS4



HP			48	50	54	60
Model Name	Combination Unit		ARWN480LAS4	ARWN500LAS4	ARWN540LAS4	ARWN600LAS4
	Independent Unit		ARWN200LAS4 ARWN140LAS4 ARWN140LAS4	ARWN200DAS4 ARWN200DAS4 ARWN100DAS4	ARWN200LAS4 ARWN200LAS4 ARWN140LAS4	ARWN200LAS4 ARWN200LAS4 ARWN200LAS4
Capacity	Cooling	kW	134.4	140.0	151.2	168.0
	Heating	kW	151.2	157.5	170.1	189.0
Input	Cooling	kW	26.88	27.49	30.24	33.60
	Heating	kW	28.01	28.68	31.51	35.01
Casing Color			Warm Gray , Mornig Gray	Warm Gray , Mornig Gray	Warm Gray , Mornig Gray	Warm Gray , Mornig Gray
Compressor	Type		Hermetically Sealed Scroll	Hermetically Sealed Scroll	Hermetically Sealed Scroll	Hermetically Sealed Scroll
	Combination		(Inverter) x 3	(Inverter) x 3	(Inverter) x 3	(Inverter) x 3
	Piston Displacement	cm ³ /rev	62.1 + 43.8 + 43.8	62.1 + 62.1 + 43.8	62.1 + 62.1 + 43.8	62.1 + 62.1 + 62.1
	Number of revolution	rev/min	Inverter 3,600 at 60Hz	Inverter 3,600 at 60Hz	Inverter 3,600 at 60Hz	Inverter 3,600 at 60Hz
	Motor Output	kW	5.3 + 4.2 + 4.2	5.3 + 5.3 + 4.2	5.3 + 5.3 + 4.2	5.3 + 5.3 + 5.3
	Starting Method		Direct On Line	Direct On Line	Direct On Line	Direct On Line
	Oil Type		FVC68D(PVE)	FVC68D(PVE)	FVC68D(PVE)	FVC68D(PVE)
	Oil Charge Amount	cc	(1 400 + 1 200 + 1 200) + 1 600 x 3	(1 400 + 1 400 + 1 200) + 1 600 x 3	(1 400 + 1 400 + 1 200) + 1 600 x 3	(1 400 + 1 600) x 3
Heat Exchanger	Type		Stainless Steel Plate	Stainless Steel Plate	Stainless Steel Plate	Stainless Steel Plate
	Maximum Pressure Resistance	kgf/cm ²	45	45	45	45
	Head Loss	kPa	30.1 + 28.6 + 28.6	30.1 + 30.1 + 15.8	30.1 + 28.6 + 28.6	30.1 + 30.1 + 30.1
	Rated Water Flow	LPM	192 + 135 + 135	192 + 192 + 96	192 + 192 + 135	192 + 192 + 192
Temp. range of Circulation water	Cooling		10°C - 45°C(50°F - 113°F)	10°C - 45°C(50°F - 113°F)	10°C - 45°C(50°F - 113°F)	10°C - 45°C(50°F - 113°F)
	Heating		-5°C - 45°C(23°F - 113°F)	-5°C - 45°C(23°F - 113°F)	-5°C - 45°C(23°F - 113°F)	-5°C - 45°C(23°F - 113°F)
Refrigerant Connecting Pipes	Liquid Pipes	mm(inch)	19.05(3/4)	19.05(3/4)	19.05(3/4)	19.05(3/4)
	Gas Pipes	mm(inch)	41.3(1-5/8)	41.3(1-5/8)	41.3(1-5/8)	41.3(1-5/8)
Water Connecting Pipes	Inlet	mm	PT40 + PT40 + PT40 (Internal)	PT40 + PT40 + PT40 (Internal)	PT40 + PT40 + PT40 (Internal)	PT40 + PT40 + PT40 (Internal)
	Outlet	mm	PT40 + PT40 + PT40 (Internal)	PT40 + PT40 + PT40 (Internal)	PT40 + PT40 + PT40 (Internal)	PT40 + PT40 + PT40 (Internal)
	Drain Outlet	mm	PT20 (3/4, External)	PT20 (3/4, External)	PT20 (3/4, External)	PT20 (3/4, External)
Dimensions (W x H x D)	mm		(755 x 997 x 500) x 3	(755 x 997 x 500) x 3	(755 x 997 x 500) x 3	(755 x 997 x 500) x 3
	inch		(29-23/32 x 39-1/4 x 19-11/16) x 3	(29-23/32 x 39-1/4 x 19-11/16) x 3	(29-23/32 x 39-1/4 x 19-11/16) x 3	(29-23/32 x 39-1/4 x 19-11/16) x 3
Net Weight	kg		(140 x 1) + (127 X 2)	(140 x 2) + (127 X 1)	(140 x 2) + (127 X 1)	140 x 3
	lbs		(309 x 1) + (280 X 2)	(309 x 2) + (280X1)	(309 x 2) + (280X1)	309 x 3
Transmission Cable (CVV-SB)	mm ²		1.0 - 1.5 x 2C	1.0 - 1.5 x 2C	1.0 - 1.5 x 2C	1.0 - 1.5 x 2C
Refrigerant	Name		R410A	R410A	R410A	R410A
	Charge Amount	kg	3.0 + 5.8 + 5.8	3.0 + 3.0 + 5.8	3.0 + 3.0 + 5.8	3.0 + 3.0 + 3.0
	Control Device		EEV	EEV	EEV	EEV
Power Supply		∅ / V / Hz	3 / 380 - 415 / 50	3 / 380 - 415 / 50	3 / 380 - 415 / 50	3 / 380 - 415 / 50
			3 / 380 / 60	3 / 380 / 60	3 / 380 / 60	3 / 380 / 60
Sound Pressure Level	Cooling	dB(A)	60	58	60	56
	Heating	dB(A)	62	63	62	62
Sound Power Level	Cooling	dB(A)	74	72	74	70
	Heating	dB(A)	76	77	76	76

* This product contains Fluorinated Greenhouse Gases. (R410A)
 Note : 1. Capacities and Inputs are based on the following conditions
 - Cooling : Indoor temp. 27°C (80.6°F) DB / 19°C (66.2°F) WB, Water inlet temp. 30°C (86°F), Interconnecting piping length 7.5m, Level difference of zero
 - Heating : Indoor temp. 20°C (68°F) DB, Water inlet temp. 20°C (68°F)
 2. Capacities are net capacities
 3. Due to our policy of innovation some specifications may be changed without notification
 4. Add an anti freeze to circulation water when outside unit is operating under 10°C (50°F), and change the DIP switch on main PCB. (For more information on installation section.)

MULTI V WATER IV

HEAT PUMP

ARWN620LAS4 / ARWN640LAS4 / ARWN680LAS4



HP			62	64	68
Model Name	Combination Unit		ARWN620LAS4	ARWN640LAS4	ARWN680LAS4
	Independent Unit		ARWN200LAS4 ARWN200LAS4 ARWN140LAS4 ARWN080LAS4	ARWN200LAS4 ARWN200LAS4 ARWN140LAS4 ARWN100LAS4	ARWN200LAS4 ARWN200LAS4 ARWN140LAS4 ARWN140LAS4
Capacity	Cooling	kW	173.6	179.2	190.4
	Heating	kW	195.3	201.6	214.2
Input	Cooling	kW	34.10	35.33	38.08
	Heating	kW	35.71	36.85	39.68
Casing Color			Warm Gray , Mornig Gray	Warm Gray , Mornig Gray	Warm Gray , Mornig Gray
Compressor	Type		Hermetically Sealed Scroll	Hermetically Sealed Scroll	Hermetically Sealed Scroll
	Combination		(Inverter) x 4	(Inverter) x 4	(Inverter) x 4
	Piston Displacement	cm ³ /rev	62.1 + 62.1 + 43.8 + 43.8	62.1 + 62.1 + 43.8 + 43.8	62.1 + 62.1 + 43.8 + 43.8
	Number of revolution	rev/min	Inverter 3,600 at 60Hz	Inverter 3,600 at 60Hz	Inverter 3,600 at 60Hz
	Motor Output	kW	5.3 + 5.3 + 4.2 + 4.2	5.3 + 5.3 + 4.2 + 4.2	5.3 + 5.3 + 4.2 + 4.2
	Starting Method		Direct On Line	Direct On Line	Direct On Line
	Oil Type		FVC68D(PVE)	FVC68D(PVE)	FVC71D(PVE)
	Oil Charge Amount	cc	(1 400 x 2 + 1200 x 2) + (1 600 x 4)	(1 400 x 2 + 1200 x 2) + (1 600 x 4)	(1 400 x 2 + 1200 x 2) + (1 600 x 4)
Heat Exchanger	Type		Stainless Steel Plate	Stainless Steel Plate	Stainless Steel Plate
	Maximum Pressure Resistance	kgf/cm ²	45	45	45
	Head Loss	kPa	30.1 + 30.1 + 28.6 + 10.7	30.1 + 30.1 + 28.6 + 15.8	30.1 + 30.1 + 28.6 + 28.6
	Rated Water Flow	LPM	192 + 192 + 135 + 77	192 + 192 + 135 + 96	192 + 192 + 135 + 135
Temp. range of	Cooling		10°C - 45°C(50°F - 113°F)	10°C - 45°C(50°F - 113°F)	10°C - 45°C(50°F - 116°F)
	Heating		-5°C - 45°C(23°F - 113°F)	-5°C - 45°C(23°F - 113°F)	-5°C - 45°C(23°F - 116°F)
Circulation water	Cooling		10°C - 45°C(50°F - 113°F)	10°C - 45°C(50°F - 113°F)	10°C - 45°C(50°F - 116°F)
	Heating		-5°C - 45°C(23°F - 113°F)	-5°C - 45°C(23°F - 113°F)	-5°C - 45°C(23°F - 116°F)
Refrigerant Connecting Pipes	Liquid Pipes	mm(inch)	19.05(3/4)	19.05(3/4)	22.2(7/8)
	Gas Pipes	mm(inch)	41.3(1-5/8)	41.3(1-5/8)	53.98(2-1/8)
Water Connecting Pipes	Inlet	mm	PT40 + PT40 + PT40 (Internal)	PT40 + PT40 + PT40 (Internal)	PT 40 + PT 40 + PT 40 + PT40
	Outlet	mm	PT40 + PT40 + PT40 (Internal)	PT40 + PT40 + PT40 (Internal)	PT 40 + PT 40 + PT 40 + PT40
	Drain Outlet	mm	PT20 (3/4, External)	PT20 (3/4, External)	PT20 (3/4, External)
Dimensions (W x H x D)	mm		(755 x 997 x 500) x 4	(755 x 997 x 500) x 4	(755 x 997 x 500) x 4
	inch		(29-23/32 x 39-1/4 x 19-11/16) x 4	(29-23/32 x 39-1/4 x 19-11/16) x 4	(29-23/32 x 39-1/4 x 19-11/16) x 4
Net Weight	kg		(140 x 2) + (127 X 2)	(140 x 2) + (127 X 2)	(140 x 2) + (127 X 2)
	lbs		(309 x 2) + (280X2)	(309 x 2) + (280X2)	(309 x 2) + (280 X 2)
Transmission Cable (CVV-SB)	mm ²		1.0 -1.5 x 2C	1.0 -1.5 x 2C	1.0 -1.5 x 5C
Refrigerant	Name		R410A	R410A	R410A
	Charge Amount	kg	5.8 + 5.8 + 3.0 + 3.0	5.8 + 5.8 + 3.0 + 3.0	5.8 + 5.8 + 3.0 + 3.0
	Control Device		EEV	EEV	EEV
Power Supply	∅ / V / Hz		3 / 380 - 415 / 50	3 / 380 - 415 / 50	6 / 380 - 415 / 50
			3 / 380 / 60	3 / 380 / 60	6 / 380 / 60
Sound Pressure Level	Cooling	dB(A)	61	61	61
	Heating	dB(A)	64	64	63
Sound Power Level	Cooling	dB(A)	75	75	75
	Heating	dB(A)	79	79	77

* This product contains Fluorinated Greenhouse Gases. (R410A)
 Note : 1. Capacities and Inputs are based on the following conditions
 - Cooling : Indoor temp. 27°C (80.6°F) DB / 19°C (66.2°F) WB, Water inlet temp. 30°C (86°F), Interconnecting piping length 7.5m, Level difference of zero
 - Heating : Indoor temp. 20°C (68°F) DB, Water inlet temp. 20°C (68°F)
 2. Capacities are net capacities
 3. Due to our policy of innovation some specifications may be changed without notification
 4. Add an anti freeze to circulation water when outside unit is operating under 10°C (50°F), and change the DIP switch on main PCB. (For more information on installation section.)

HEAT PUMP

ARWN700LAS4 / ARWN740LAS4 / ARWN800LAS4



HP			70	74	80
Model Name	Combination Unit		ARWN700LAS4	ARWN740LAS4	ARWN800LAS4
	Independent Unit		ARWN200LAS4 ARWN200LAS4 ARWN200LAS4 ARWN100LAS4	ARWN200LAS4 ARWN200LAS4 ARWN200LAS4 ARWN140LAS4	ARWN200LAS4 ARWN200LAS4 ARWN200LAS4 ARWN200LAS4
Capacity	Cooling	kW	196.0	184.8	201.6
	Heating	kW	220.5	207.9	226.8
Input	Cooling	kW	38.69	35.53	38.76
	Heating	kW	40.35	37.14	40.52
Casing Color			Warm Gray , Mornig Gray	Warm Gray , Mornig Gray	Warm Gray , Mornig Gray
Compressor	Type		Hermetically Sealed Scroll	Hermetically Sealed Scroll	Hermetically Sealed Scroll
	Combination		(Inverter) x 4	(Inverter) x 4	(Inverter) x 4
	Piston Displacement	cm ³ /rev	62.1 + 62.1 + 62.1 + 43.8	62.1 + 62.1 + 62.1 + 43.8	62.1 + 62.1 + 62.1 + 62.1
	Number of revolution	rev/min	Inverter 3,600 at 60Hz	Inverter 3,600 at 60Hz	Inverter 3,600 at 60Hz
	Motor Output	kW	5.3 + 5.3 + 5.3 + 4.2	5.3 + 5.3 + 5.3 + 4.2	5.3 + 5.3 + 5.3 + 5.3
	Starting Method		Direct On Line	Direct On Line	Direct On Line
	Oil Type		FVC71D(PVE)	FVC74D(PVE)	FVC77D(PVE)
	Oil Charge Amount	cc	(1 400 x 3 + 1 200) + (1 600 x 4)	(1 400 x 3 + 1 200) + (1 600 x 4)	(1 400 + 1 600) x 4
Heat Exchanger	Type		Stainless Steel Plate	Stainless Steel Plate	Stainless Steel Plate
	Maximum Pressure Resistance	kgf/cm ²	45	45	45
	Head Loss	kPa	30.1 + 30.1 + 30.1 + 15.8	30.1 + 30.1 + 30.1 + 28.6	30.1 + 30.1 + 30.1 + 30.1
	Rated Water Flow	LPM	192 + 192 + 192 + 96	192 + 192 + 192 + 135	192 + 192 + 192 + 192
Temp. range of	Cooling		10°C - 45°C(50°F - 116°F)	10°C - 45°C(50°F - 119°F)	10°C - 45°C(50°F - 122°F)
	Heating		-5°C - 45°C(23°F - 116°F)	-5°C - 45°C(23°F - 119°F)	-5°C - 45°C(23°F - 122°F)
Circulation water	Cooling		10°C - 45°C(50°F - 116°F)	10°C - 45°C(50°F - 119°F)	10°C - 45°C(50°F - 122°F)
	Heating		-5°C - 45°C(23°F - 116°F)	-5°C - 45°C(23°F - 119°F)	-5°C - 45°C(23°F - 122°F)
Refrigerant Connecting Pipes	Liquid Pipes	mm(inch)	22.2(7/8)	22.2(7/8)	22.2(7/8)
	Gas Pipes	mm(inch)	53.98(2-1/8)	53.98(2-1/8)	53.98(2-1/8)
Water Connecting Pipes	Inlet	mm	PT 40 + PT 40 + PT 40 + PT40	PT 40 + PT 40 + PT 40 + PT 40	PT 40 + PT 40 + PT 40 + PT 40
	Outlet	mm	PT 40 + PT 40 + PT 40 + PT40	PT 40 + PT 40 + PT 40 + PT 40	PT 40 + PT 40 + PT 40 + PT 40
	Drain Outlet	mm	PT20 (3/4, External)	PT20 (3/4, External)	PT20 (3/4, External)
Dimensions (W x H x D)	mm		(755 x 997 x 500) x 4	(755 x 997 x 500) x 4	(755 x 997 x 500) x 4
	inch		(29-23/32 x 39-1/4 x 19-11/16) x 4	(29-23/32 x 39-1/4 x 19-11/16) x 4	(29-23/32 x 39-1/4 x 19-11/16) x 4
Net Weight	kg		(140 x 2) + (127 X 2)	(140 x 3) + (127 x 1)	140 x 4
	lbs		(309 x 2) + (280 X 2)	(309 x 3) + (280 x 1)	309 x 4
Transmission Cable (CVV-SB)	mm ²		1.0 -1.5 x 5C	1.0 -1.5 x 8C	1.0 -1.5 x 11C
Refrigerant	Name		R410A	R410A	R410A
	Charge Amount	kg	5.8 + 5.8 + 3.0 + 3.0	3.0 + 3.0 + 3.0 + 5.8	3.0 + 3.0 + 3.0 + 3.0
	Control Device		EEV	EEV	EEV
Power Supply	∅ / V / Hz		6 / 380 - 415 / 50	9 / 380 - 415 / 50	12 / 380 - 415 / 50
			6 / 380 / 60	9 / 380 / 60	12 / 380 / 60
Sound Pressure Level	Cooling	dB(A)	60	61	57
	Heating	dB(A)	65	63	63
Sound Power Level	Cooling	dB(A)	74	75	71
	Heating	dB(A)	80	77	77

* This product contains Fluorinated Greenhouse Gases. (R410A)
 Note : 1. Capacities and Inputs are based on the following conditions
 - Cooling : Indoor temp. 27°C (80.6°F) DB / 19°C (66.2°F) WB, Water inlet temp. 30°C (86°F), Interconnecting piping length 7.5m, Level difference of zero
 - Heating : Indoor temp. 20°C (68°F) DB, Water inlet temp. 20°C (68°F)
 2. Capacities are net capacities
 3. Due to our policy of innovation some specifications may be changed without notification
 4. Add an anti freeze to circulation water when outside unit is operating under 10°C (50°F), and change the DIP switch on main PCB. (For more information on installation section.)

MULTI V WATER IV

HEAT RECOVERY

ARWB080LAS4 / ARWB100LAS4 / ARWB140LAS4 / ARWB200LAS4



HP			8	10	14	20
Model Name	Combination Unit		ARWB080LAS4	ARWB100LAS4	ARWB140LAS4	ARWB200LAS4
	Independent Unit		ARWB080LAS4	ARWB100LAS4	ARWB140LAS4	ARWB200LAS4
Capacity	Cooling	kW	22.4	28.0	39.2	56.0
	Heating	kW	25.2	31.5	44.1	63.0
Input	Cooling	kW	3.86	5.09	7.84	11.20
	Heating	kW	4.20	5.34	8.17	11.67
Casing Color			Warm Gray , Mornig Gray	Warm Gray , Mornig Gray	Warm Gray , Mornig Gray	Warm Gray , Mornig Gray
Compressor	Type		Hermetically Sealed Scroll	Hermetically Sealed Scroll	Hermetically Sealed Scroll	Hermetically Sealed Scroll
	Combination		(Inverter) x 1	(Inverter) x 1	(Inverter) x 1	(Inverter) x 1
	Piston Displacement	cm ³ /rev	43.8	43.8	43.8	62.1
	Number of revolution	rev/min	Inverter 3,600 at 60Hz	Inverter 3,600 at 60Hz	Inverter 3,600 at 60Hz	Inverter 3,600 at 60Hz
	Motor Output	kW	4.2	4.2	4.2	5.3
	Starting Method		Direct On Line	Direct On Line	Direct On Line	Direct On Line
	Oil Type		FVC68D(PVE)	FVC68D(PVE)	FVC68D(PVE)	FVC68D(PVE)
	Oil Charge Amount	cc	1 200 + 1 600	1 200 + 1 600	1 200 + 1 600	1 400 + 1 600
Heat Exchanger	Type		Stainless Steel Plate	Stainless Steel Plate	Stainless Steel Plate	Stainless Steel Plate
	Maximum Pressure Resistance	kgf/cm ²	45	45	45	45
	Head Loss	kPa	10.7	15.8	28.6	30.1
	Rated Water Flow	LPM	77	96	135	192
Temp. range of	Cooling		10°C - 45°C(50°F - 113°F)	10°C - 45°C(50°F - 113°F)	10°C - 45°C(50°F - 113°F)	10°C - 45°C(50°F - 113°F)
Circulation water	Heating		-5°C - 45°C(23°F - 113°F)	-5°C - 45°C(23°F - 113°F)	5°C - 45°C(23°F - 113°F)	-5°C - 45°C(23°F - 113°F)
Refrigerant Connecting Pipes	Liquid Pipes	mm(inch)	9.52(3/8)	9.52(3/8)	12.7(1/2)	12.7(1/2)
	Low Pressure Gas Pipes	mm(inch)	22.2(7/8)	22.2(7/8)	25.4(1)	28.58(1-1/8)
	High Pressure Gas Pipes	mm(inch)	19.05(3/4)	19.05(3/4)	19.05(3/4)	19.05(3/4)
Water Connecting Pipes	Inlet	mm	PT40 (1-1/2, Internal)	PT40 (1-1/2, Internal)	PT40 (1-1/2, Internal)	PT40 (1-1/2, Internal)
	Outlet	mm	PT40 (1-1/2, Internal)	PT40 (1-1/2, Internal)	PT40 (1-1/2, Internal)	PT40 (1-1/2, Internal)
	Drain Outlet	mm	PT20 (3/4, External)	PT20 (3/4, External)	PT20 (3/4, External)	PT20 (3/4, External)
Dimensions (W x H x D)	mm		(755 x 500 x 997) x 1	(755 x 500 x 997) x 1	(755 x 500 x 997) x 1	(755 x 500 x 997) x 1
	inch		(29-23/32 x 39-1/4 x 19-11/16) x 1	(29-23/32 x 39-1/4 x 19-11/16) x 1	(29-23/32 x 39-1/4 x 19-11/16) x 1	(29-23/32 x 39-1/4 x 19-11/16) x 1
Net Weight	kg		127 x 1	127 x 1	127 x 1	140 x 1
	lbs		280 x 1	280 x 1	280 x 1	309 x 1
Transmission Cable (CVV-SB)	mm ²		1.0 -1.5 x 2C	1.0 -1.5 x 2C	1.0 -1.5 x 2C	1.0 -1.5 x 2C
Refrigerant	Name		R410A	R410A	R412A	R410A
	Charge Amount	kg	5.8	5.8	5.8	3.0
	Control Device		EEV	EEV	EEV	EEV
Power Supply	∅ / V / Hz		3 / 380 - 415 / 50	3 / 380 - 415 / 50	3 / 380 - 415 / 50	3 / 380 - 415 / 50
			3 / 380 / 60	3 / 380 / 60	3 / 380 / 60	3 / 380 / 60
Sound Pressure Level	Cooling	dB(A)	47	50	58	54
	Heating	dB(A)	51	53	57	60
Sound Power Level	Cooling	dB(A)	59	62	70	66
	Heating	dB(A)	63	65	69	72

* This product contains Fluorinated Greenhouse Gases. (R410A)
 Note : 1. Capacities and Inputs are based on the following conditions
 - Cooling : Indoor temp. 27°C (80.6°F) DB / 19°C (66.2°F) WB, Water inlet temp. 30°C (86°F), Interconnecting piping length 7.5m, Level difference of zero
 - Heating : Indoor temp. 20°C (68°F) DB, Water inlet temp. 20°C (68°F)
 2. Capacities are net capacities
 3. Due to our policy of innovation some specifications may be changed without notification
 4. Add an anti freeze to circulation water when outside unit is operating under 10°C (50°F), and change the DIP switch on main PCB. (For more information on installation section.)

HEAT RECOVERY

ARWB220LAS4 / ARWB240LAS4 / ARWB280LAS4 / ARWB300LAS4



HP			22	24	28	30
Model Name	Combination Unit		ARWB220LAS4	ARWB240LAS4	ARWB280LAS4	ARWB300LAS4
	Independent Unit		ARWB140LAS4 ARWB080LAS4	ARWB140LAS4 ARWB100LAS4	ARWB140LAS4 ARWB140LAS4	ARWB200LAS4 ARWB100LAS4
Capacity	Cooling	kW	61.6	67.2	78.4	84.0
	Heating	kW	69.3	75.6	88.2	94.5
Input	Cooling	kW	11.70	12.93	15.68	16.29
	Heating	kW	12.37	13.51	16.34	17.01
Casing Color			Warm Gray , Mornig Gray	Warm Gray , Mornig Gray	Warm Gray , Mornig Gray	Warm Gray , Mornig Gray
Compressor	Type		Hermetically Sealed Scroll	Hermetically Sealed Scroll	Hermetically Sealed Scroll	Hermetically Sealed Scroll
	Combination		(Inverter) x 2	(Inverter) x 2	(Inverter) x 2	(Inverter) x 2
	Piston Displacement	cm ³ /rev	43.8 + 43.8	43.8 + 43.8	43.8 + 43.8	62.1 + 43.8
	Number of revolution	rev/min	Inverter 3,600 at 60Hz	Inverter 3,600 at 60Hz	Inverter 3,600 at 60Hz	Inverter 3,600 at 60Hz
	Motor Output	kW	4.2+4.2	4.2 + 4.2	4.2 + 4.2	5.3 + 4.2
	Starting Method		Direct On Line	Direct On Line	Direct On Line	Direct On Line
	Oil Type		FVC68D(PVE)	FVC68D(PVE)	FVC68D(PVE)	FVC68D(PVE)
	Oil Charge Amount	cc	(1 200 + 1 600) x 2	(1 200 + 1 600) x 2	(1 200 + 1 600) x 2	(1 400 + 1 200) + 1 600 x 2
Heat Exchanger	Type		Stainless Steel Plate	Stainless Steel Plate	Stainless Steel Plate	Stainless Steel Plate
	Maximum Pressure Resistance	kgf/cm ²	45	45	45	45
	Head Loss	kPa	28.6 + 10.7	28.6 + 15.8	28.6 + 28.6	30.1 + 15.8
	Rated Water Flow	LPM	135 + 77	135 + 96	135 + 135	192 + 96
Temp. range of	Cooling		10°C - 45°C(50°F - 113°F)	10°C - 45°C(50°F - 113°F)	10°C - 45°C(50°F - 113°F)	10°C - 45°C(50°F - 113°F)
Circulation water	Heating		-5°C - 45°C(23°F - 113°F)	-5°C - 45°C(23°F - 113°F)	-5°C - 45°C(23°F - 113°F)	-5°C - 45°C(23°F - 113°F)
Refrigerant Connecting Pipes	Liquid Pipes	mm(inch)	19.05(3/4)	19.05(3/4)	19.05(3/4)	19.05(3/4)
	Low Pressure Gas Pipes	mm(inch)	34.9(1-3/8)	34.9(1-3/8)	34.9(1-3/8)	34.9(1-3/8)
	High Pressure Gas Pipes	mm(inch)	28.58(1-1/8)	28.58(1-1/8)	28.58(1-1/8)	28.58(1-1/8)
Water Connecting Pipes	Inlet	mm	PT40 + PT40 (Internal)	PT40 + PT40 (Internal)	PT40 + PT40 (Internal)	PT40 + PT40 (Internal)
	Outlet	mm	PT40 + PT40 (Internal)	PT40 + PT40 (Internal)	PT40 + PT40 (Internal)	PT40 + PT40 (Internal)
	Drain Outlet	mm	PT20 (3/4, External)	PT20 (3/4, External)	PT20 (3/4, External)	PT20 (3/4, External)
Dimensions (W x H x D)	mm		(755 x 997 x 500) x 2	(755 x 997 x 500) x 2	(755 x 997 x 500) x 2	(755 x 997 x 500) x 2
	inch		(29-23/32 x 39-1/4 x 19-11/16) x 2	(29-23/32 x 39-1/4 x 19-11/16) x 2	(29-23/32 x 39-1/4 x 19-11/16) x 2	(29-23/32 x 39-1/4 x 19-11/16) x 2
Net Weight	kg		127 x 2	127 x 2	127 x 2	(140 x 1) + (127 x 1)
	lbs		280 x 2	280 x 2	280 x 2	(309 x 1) + (280 x 1)
Transmission Cable (CVV-SB)	mm ²		1.0 -1.5 x 2C	1.0 -1.5 x 2C	1.0 -1.5 x 2C	1.0 -1.5 x 2C
Refrigerant	Name		R410A	R410A	R410A	R410A
	Charge Amount	kg	5.8 + 5.8	5.8 + 5.8	5.8 + 5.8	3.0 + 5.8
	Control Device		EEV	EEV	EEV	EEV
Power Supply	∅ / V / Hz		3 / 380 - 415 / 50	3 / 380 - 415 / 50	3 / 380 - 415 / 50	3 / 380 - 415 / 50
			3 / 380 / 60	3 / 380 / 60	3 / 380 / 60	3 / 380 / 60
Sound Pressure Level	Cooling	dB(A)	58	59	59	55
	Heating	dB(A)	58	58	58	61
Sound Power Level	Cooling	dB(A)	71	72	72	68
	Heating	dB(A)	71	71	71	74

* This product contains Fluorinated Greenhouse Gases. (R410A)
 Note : 1. Capacities and Inputs are based on the following conditions
 - Cooling : Indoor temp. 27°C (80.6°F) DB / 19°C (66.2°F) WB, Water inlet temp. 30°C (86°F), Interconnecting piping length 7.5m, Level difference of zero
 - Heating : Indoor temp. 20°C (68°F) DB, Water inlet temp. 20°C (68°F)
 2. Capacities are net capacities
 3. Due to our policy of innovation some specifications may be changed without notification
 4. Add an anti freeze to circulation water when outside unit is operating under 10°C (50°F), and change the DIP switch on main PCB. (For more information on installation section.)

MULTI V WATER IV

HEAT RECOVERY

ARWB340LAS4 / ARWB400LAS4 / ARWB420LAS4 / ARWB440LAS4



HP			34	40	42	44
Model Name	Combination Unit		ARWB340LAS4	ARWB400LAS4	ARWB420LAS4	ARWB440LAS4
	Independent Unit		ARWB200LAS4 ARWB140LAS4	ARWB200LAS4 ARWB200LAS4	ARWB200LAS4 ARWB140LAS4 ARWB080LAS4	ARWB200LAS4 ARWB140LAS4 ARWB100LAS4
Capacity	Cooling	kW	95.2	112.0	117.6	123.2
	Heating	kW	107.1	126.0	132.3	138.6
Input	Cooling	kW	19.04	22.40	22.90	24.13
	Heating	kW	19.84	23.34	24.04	25.18
Casing Color			Warm Gray , Mornig Gray	Warm Gray , Mornig Gray	Warm Gray , Mornig Gray	Warm Gray , Mornig Gray
Compressor	Type		Hermetically Sealed Scroll	Hermetically Sealed Scroll	Hermetically Sealed Scroll	Hermetically Sealed Scroll
	Combination		(Inverter) x 2	(Inverter) x 2	(Inverter) x 3	(Inverter) x 3
	Piston Displacement	cm ³ /rev	43.8 + 62.1	62.1 + 62.1	62.1 + 43.8 + 43.8	62.1 + 43.8 + 43.8
	Number of revolution	rev/min	Inverter 3,600 at 60Hz	Inverter 3,600 at 60Hz	Inverter 3,600 at 60Hz	Inverter 3,600 at 60Hz
	Motor Output	kW	4.2 + 5.3	5.3 + 5.3	5.3 + 4.2 + 4.2	5.3 + 4.2 + 4.2
	Starting Method		Direct On Line	Direct On Line	Direct On Line	Direct On Line
	Oil Type		FVC68D(PVE)	FVC68D(PVE)	FVC68D(PVE)	FVC68D(PVE)
	Oil Charge Amount	cc	(1 400 + 1 200) + 1 600 x 2	(1 400 + 1 600) x 2	(1 400 + 1 200 + 1 200) + 1 600 x 3	(1 400 + 1 200 + 1 200) + 1 600 x 3
Heat Exchanger	Type		Stainless Steel Plate	Stainless Steel Plate	Stainless Steel Plate	Stainless Steel Plate
	Maximum Pressure Resistance	kgf/cm ²	45	45	45	45
	Head Loss	kPa	30.1 + 28.6	30.1 + 30.1	30.1 + 28.6 + 10.7	30.1 + 28.6 + 15.8
	Rated Water Flow	LPM	192 + 135	192 + 192	192 + 135 + 77	192 + 135 + 96
Temp. range of	Cooling		10°C - 45°C(50°F - 113°F)	10°C - 45°C(50°F - 113°F)	10°C - 45°C(50°F - 113°F)	10°C - 45°C(50°F - 113°F)
	Heating		-5°C - 45°C(23°F - 113°F)	-5°C - 45°C(23°F - 113°F)	-5°C - 45°C(23°F - 113°F)	-5°C - 45°C(23°F - 113°F)
Circulation water	Liquid Pipes	mm(inch)	19.05(3/4)	19.05(3/4)	19.05(3/4)	19.05(3/4)
	Low Pressure Gas Pipes	mm(inch)	34.9(1-3/8)	41.3(1-5/8)	41.3(1-5/8)	41.3(1-5/8)
	High Pressure Gas Pipes	mm(inch)	28.58(1-1/8)	34.9(1-3/8)	34.9(1-3/8)	34.9(1-3/8)
Water Connecting Pipes	Inlet	mm	PT40 + PT40 (Internal)	PT40 + PT40 (Internal)	PT40 + PT40 + PT40 (Internal)	PT40 + PT40 + PT40 (Internal)
	Outlet	mm	PT40 + PT40 (Internal)	PT40 + PT40 (Internal)	PT40 + PT40 + PT40 (Internal)	PT40 + PT40 + PT40 (Internal)
	Drain Outlet	mm	PT20 (3/4, External)	PT20 (3/4, External)	PT20 (3/4, External)	PT20 (3/4, External)
Dimensions (W x H x D)	mm		(755 x 997 x 500) x 2	(755 x 997 x 500) x 2	(755 x 997 x 500) x 3	(755 x 997 x 500) x 3
	inch		(29-23/32 x 39-1/4 x 19-11/16) x 2	(29-23/32 x 39-1/4 x 19-11/16) x 2	(29-23/32 x 39-1/4 x 19-11/16) x 3	(29-23/32 x 39-1/4 x 19-11/16) x 3
Net Weight	kg		(140 x 1) + (127 x 1)	140 x 2	(140 x 1) + (127 X 2)	(140 x 1) + (127 X 2)
	lbs		(309 x 1) + (280 x 1)	309 x 2	(309 x 1) + (280 X 2)	(309 x 1) + (280 X 2)
Transmission Cable (CVV-SB)	mm ²		1.0 -1.5 x 2C	1.0 -1.5 x 2C	1.0 -1.5 x 2C	1.0 -1.5 x 2C
Refrigerant	Name		R410A	R410A	R410A	R410A
	Charge Amount	kg	3.0 + 5.8	3.0 + 3.0	3.0 + 5.8 + 5.8	3.0 + 5.8 + 5.8
	Control Device		EEV	EEV	EEV	EEV
Power Supply	∅ / V / Hz		3 / 380 - 415 / 50	3 / 380 - 415 / 50	3 / 380 - 415 / 50	3 / 380 - 415 / 50
			3 / 380 / 60	3 / 380 / 60	3 / 380 / 60	3 / 380 / 60
Sound Pressure Level	Cooling	dB(A)	59	55	60	60
	Heating	dB(A)	61	61	62	62
Sound Power Level	Cooling	dB(A)	72	68	73	74
	Heating	dB(A)	74	74	76	76

* This product contains Fluorinated Greenhouse Gases. (R410A)
 Note : 1. Capacities and Inputs are based on the following conditions
 - Cooling : Indoor temp. 27°C (80.6°F) DB / 19°C (66.2°F) WB, Water inlet temp. 30°C (86°F), Interconnecting piping length 7.5m, Level difference of zero
 - Heating : Indoor temp. 20°C (68°F) DB, Water inlet temp. 20°C (68°F)
 2. Capacities are net capacities
 3. Due to our policy of innovation some specifications may be changed without notification
 4. Add an anti freeze to circulation water when outside unit is operating under 10°C (50°F), and change the DIP switch on main PCB. (For more information on installation section.)

HEAT RECOVERY

ARWB480LAS4 / ARWB500LAS4 / ARWB540LAS4 / ARWB600LAS4



HP			48	50	54	60
Model Name	Combination Unit		ARWB480LAS4	ARWB500LAS4	ARWB540LAS4	ARWB600LAS4
	Independent Unit		ARWB200LAS4 ARWB140LAS4 ARWB140LAS4	ARWB200DAS4 ARWB200DAS4 ARWB100DAS4	ARWB200LAS4 ARWB200LAS4 ARWB140LAS4	ARWB200LAS4 ARWB200LAS4 ARWB200LAS4
Capacity	Cooling	kW	134.4	140.0	151.2	168.0
	Heating	kW	151.2	157.5	170.1	189.0
Input	Cooling	kW	26.88	27.49	30.24	33.60
	Heating	kW	28.01	28.68	31.51	35.01
Casing Color			Warm Gray , Mornig Gray	Warm Gray , Mornig Gray	Warm Gray , Mornig Gray	Warm Gray , Mornig Gray
Compressor	Type		Hermetically Sealed Scroll	Hermetically Sealed Scroll	Hermetically Sealed Scroll	Hermetically Sealed Scroll
	Combination		(Inverter) x 3	(Inverter) x 3	(Inverter) x 3	(Inverter) x 3
	Piston Displacement	cm ³ /rev	62.1 + 43.8 + 43.8	62.1 + 62.1 + 43.8	62.1 + 62.1 + 43.8	62.1 + 62.1 + 62.1
	Number of revolution	rev/min	Inverter 3,600 at 60Hz	Inverter 3,600 at 60Hz	Inverter 3,600 at 60Hz	Inverter 3,600 at 60Hz
	Motor Output	kW	5.3 + 4.2 + 4.2	5.3 + 5.3 + 4.2	5.3 + 5.3 + 4.2	5.3 + 5.3 + 5.3
	Starting Method		Direct On Line	Direct On Line	Direct On Line	Direct On Line
	Oil Type		FVC68D(PVE)	FVC68D(PVE)	FVC68D(PVE)	FVC68D(PVE)
	Oil Charge Amount	cc	(1 400 + 1 200 + 1 200) + 1 600 x 3	(1 400 + 1 400 + 1 200) + 1 600 x 3	(1 400 + 1 400 + 1 200) + 1 600 x 3	(1 400 + 1 600) x 3
Heat Exchanger	Type		Stainless Steel Plate	Stainless Steel Plate	Stainless Steel Plate	Stainless Steel Plate
	Maximum Pressure Resistance	kgf/cm ²	45	45	45	45
	Head Loss	kPa	30.1 + 28.6 + 28.6	30.1 + 30.1 + 15.8	30.1 + 28.6 + 28.6	30.1 + 30.1 + 30.1
	Rated Water Flow	LPM	192 + 135 + 135	192 + 192 + 96	192 + 192 + 135	192 + 192 + 192
Temp. range of	Cooling		10°C - 45°C(50°F - 113°F)	10°C - 45°C(50°F - 113°F)	10°C - 45°C(50°F - 113°F)	10°C - 45°C(50°F - 113°F)
	Heating		-5°C - 45°C(23°F - 113°F)	-5°C - 45°C(23°F - 113°F)	-5°C - 45°C(23°F - 113°F)	-5°C - 45°C(23°F - 113°F)
Circulation water	Liquid Pipes	mm(inch)	19.05(3/4)	19.05(3/4)	19.05(3/4)	19.05(3/4)
	Low Pressure Gas Pipes	mm(inch)	41.3(1-5/8)	41.3(1-5/8)	41.3(1-5/8)	41.3(1-5/8)
	High Pressure Gas Pipes	mm(inch)	34.9(1-3/8)	34.9(1-3/8)	34.9(1-3/8)	34.9(1-3/8)
Water Connecting Pipes	Inlet	mm	PT40 + PT40 + PT40 (Internal)	PT40 + PT40 + PT40 (Internal)	PT40 + PT40 + PT40 (Internal)	PT40 + PT40 + PT40 (Internal)
	Outlet	mm	PT40 + PT40 + PT40 (Internal)	PT40 + PT40 + PT40 (Internal)	PT40 + PT40 + PT40 (Internal)	PT40 + PT40 + PT40 (Internal)
	Drain Outlet	mm	PT20 (3/4, External)	PT20 (3/4, External)	PT20 (3/4, External)	PT20 (3/4, External)
Dimensions (W x H x D)	mm		(755 x 997 x 500) x 3	(755 x 997 x 500) x 3	(755 x 997 x 500) x 3	(755 x 997 x 500) x 3
	inch		(29-23/32 x 39-1/4 x 19-11/16) x 3	(29-23/32 x 39-1/4 x 19-11/16) x 3	(29-23/32 x 39-1/4 x 19-11/16) x 3	(29-23/32 x 39-1/4 x 19-11/16) x 3
Net Weight	kg		(140 x 1) + (127 X 2)	(140 x 2) + (127 X 1)	(140 x 2) + (127 X 1)	140 x 3
	lbs		(309 x 1) + (280 X 2)	(309 x 2) + (280X1)	(309 x 2) + (280X1)	309 x 3
Transmission Cable (CVV-SB)	mm ²		1.0 -1.5 x 2C	1.0 -1.5 x 2C	1.0 -1.5 x 2C	1.0 -1.5 x 2C
Refrigerant	Name		R410A	R410A	R410A	R410A
	Charge Amount	kg	3.0 + 5.8 + 5.8	3.0 + 3.0 + 5.8	3.0 + 3.0 + 5.8	3.0 + 3.0 + 3.0
	Control Device		EEV	EEV	EEV	EEV
Power Supply	∅ / V / Hz		3 / 380 - 415 / 50	3 / 380 - 415 / 50	3 / 380 - 415 / 50	3 / 380 - 415 / 50
			3 / 380 / 60	3 / 380 / 60	3 / 380 / 60	3 / 380 / 60
Sound Pressure Level	Cooling	dB(A)	60	58	60	56
	Heating	dB(A)	62	63	62	62
Sound Power Level	Cooling	dB(A)	74	72	74	70
	Heating	dB(A)	76	77	76	76

* This product contains Fluorinated Greenhouse Gases. (R410A)
 Note : 1. Capacities and Inputs are based on the following conditions
 - Cooling : Indoor temp. 27°C (80.6°F) DB / 19°C (66.2°F) WB, Water inlet temp. 30°C (86°F), Interconnecting piping length 7.5m, Level difference of zero
 - Heating : Indoor temp. 20°C (68°F) DB, Water inlet temp. 20°C (68°F)
 2. Capacities are net capacities
 3. Due to our policy of innovation some specifications may be changed without notification
 4. Add an anti freeze to circulation water when outside unit is operating under 10°C (50°F), and change the DIP switch on main PCB. (For more information on installation section.)

MULTI V WATER IV

HEAT RECOVERY

ARWB620LAS4 / ARWB640LAS4 / ARWB680LAS4



HP		62	64	68	
Model Name	Combination Unit	ARWB620LAS4	ARWB640LAS4	ARWB680LAS4	
	Independent Unit	ARWB200LAS4 ARWB200LAS4 ARWB140LAS4 ARWB080LAS4	ARWB200LAS4 ARWB200LAS4 ARWB140LAS4 ARWB100LAS4	ARWB200LAS4 ARWB200LAS4 ARWB140LAS4 ARWB140LAS4	
Capacity	Cooling	173.6	179.2	190.4	
	Heating	195.3	201.6	214.2	
Input	Cooling	34.10	35.33	38.08	
	Heating	35.71	36.85	39.68	
Casing Color		Warm Gray , Mornig Gray	Warm Gray , Mornig Gray	Warm Gray , Mornig Gray	
Compressor	Type	Hermetically Sealed Scroll	Hermetically Sealed Scroll	Hermetically Sealed Scroll	
	Combination	(Inverter) x 4	(Inverter) x 4	(Inverter) x 4	
	Piston Displacement	cm ³ /rev	62.1 + 62.1 + 43.8 + 43.8	62.1 + 62.1 + 43.8 + 43.8	62.1 + 62.1 + 43.8 + 43.8
	Number of revolution	rev/min	Inverter 3,600 at 60Hz	Inverter 3,600 at 60Hz	Inverter 3,600 at 60Hz
	Motor Output	kW	5.3 + 5.3 + 4.2 + 4.2	5.3 + 5.3 + 4.2 + 4.2	5.3 + 5.3 + 4.2 + 4.2
	Starting Method		Direct On Line	Direct On Line	Direct On Line
	Oil Type		FVC68D(PVE)	FVC68D(PVE)	FVC71D(PVE)
	Oil Charge Amount	cc	(1 400 x 2 + 1 200 x 2) + (1 600 x 4)	(1 400 x 2 + 1 200 x 2) + (1 600 x 4)	(1 400 x 2 + 1 200 x 2) + (1 600 x 4)
Heat Exchanger	Type	Stainless Steel Plate	Stainless Steel Plate	Stainless Steel Plate	
	Maximum Pressure Resistance	kgf/cm ²	45	45	
	Head Loss	kPa	30.1 + 30.1 + 28.6 + 10.7	30.1 + 30.1 + 28.6 + 15.8	30.1 + 30.1 + 28.6 + 28.6
	Rated Water Flow	LPM	192 + 192 + 135 + 77	192 + 192 + 135 + 96	192 + 192 + 135 + 135
Temp. range of	Cooling	10°C - 45°C(50°F - 113°F)	10°C - 45°C(50°F - 113°F)	10°C - 45°C(50°F - 116°F)	
	Heating	-5°C - 45°C(23°F - 113°F)	-5°C - 45°C(23°F - 113°F)	-5°C - 45°C(23°F - 116°F)	
Refrigerant Connecting Pipes	Liquid Pipes	mm(inch)	19.05(3/4)	19.05(3/4)	22.2(7/8)
	Low Pressure Gas Pipes	mm(inch)	41.3(1-5/8)	41.3(1-5/8)	53.98(2-1/8)
	High Pressure Gas Pipes	mm(inch)	34.9(1-3/8)	34.9(1-3/8)	44.5(1-3/4)
Water Connecting Pipes	Inlet	mm	PT40 + PT40 + PT40 (Internal)	PT40 + PT40 + PT40 (Internal)	PT 40 + PT 40 + PT 40 + PT40
	Outlet	mm	PT40 + PT40 + PT40 (Internal)	PT40 + PT40 + PT40 (Internal)	PT 40 + PT 40 + PT 40 + PT40
	Drain Outlet	mm	PT20 (3/4, External)	PT20 (3/4, External)	PT20 (3/4, External)
Dimensions (W x H x D)	mm	(755 x 997 x 500) x 4	(755 x 997 x 500) x 4	(755 x 997 x 500) x 4	
	inch	(29-23/32 x 39-1/4 x 19-11/16) x 4	(29-23/32 x 39-1/4 x 19-11/16) x 4	(29-23/32 x 39-1/4 x 19-11/16) x 4	
Net Weight	kg	(140 x 2) + (127 X 2)	(140 x 2) + (127 X 2)	(140 x 2) + (127 X 2)	
	lbs	(309 x 2) + (280X2)	(309 x 2) + (280X2)	(309 x 2) + (280 X 2)	
Transmission Cable (CVV-SB)	mm ²	1.0 - 1.5 x 2C	1.0 - 1.5 x 2C	1.0 - 1.5 x 5C	
Refrigerant	Name	R410A	R410A	R410A	
	Charge Amount	kg	5.8 + 5.8 + 3.0 + 3.0	5.8 + 5.8 + 3.0 + 3.0	5.8 + 5.8 + 3.0 + 3.0
	Control Device		EEV	EEV	EEV
Power Supply	Ø / V / Hz	3 / 380 - 415 / 50	3 / 380 - 415 / 50	6 / 380 - 415 / 50	
		3 / 380 / 60	3 / 380 / 60	6 / 380 / 60	
Sound Pressure Level	Cooling	dB(A)	61	61	61
	Heating	dB(A)	64	64	63
Sound Power Level	Cooling	dB(A)	75	75	75
	Heating	dB(A)	79	79	77

* This product contains Fluorinated Greenhouse Gases. (R410A)
 Note : 1. Capacities and Inputs are based on the following conditions
 - Cooling : Indoor temp. 27°C (80.6°F) DB / 19°C (66.2°F) WB, Water inlet temp. 30°C (86°F), Interconnecting piping length 7.5m, Level difference of zero
 - Heating : Indoor temp. 20°C (68°F) DB, Water inlet temp. 20°C (68°F)
 2. Capacities are net capacities
 3. Due to our policy of innovation some specifications may be changed without notification
 4. Add an anti freeze to circulation water when outside unit is operating under 10°C (50°F), and change the DIP switch on main PCB. (For more information on installation section.)

HEAT RECOVERY

ARWB700LAS4 / ARWB740LAS4 / ARWB800LAS4



HP		70	74	80	
Model Name	Combination Unit	ARWB700LAS4	ARWB740LAS4	ARWB800LAS4	
	Independent Unit	ARWB200LAS4 ARWB200LAS4 ARWB200LAS4 ARWB100LAS4	ARWB200LAS4 ARWB200LAS4 ARWB200LAS4 ARWB140LAS4	ARWB200LAS4 ARWB200LAS4 ARWB200LAS4 ARWB200LAS4	
Capacity	Cooling	196.0	184.8	201.6	
	Heating	220.5	207.9	226.8	
Input	Cooling	38.69	35.53	38.76	
	Heating	40.35	37.14	40.52	
Casing Color		Warm Gray , Mornig Gray	Warm Gray , Mornig Gray	Warm Gray , Mornig Gray	
Compressor	Type	Hermetically Sealed Scroll	Hermetically Sealed Scroll	Hermetically Sealed Scroll	
	Combination	(Inverter) x 4	(Inverter) x 4	(Inverter) x 4	
	Piston Displacement	cm ³ /rev	62.1 + 62.1 + 62.1 + 43.8	62.1 + 62.1 + 62.1 + 43.8	62.1 + 62.1 + 62.1 + 62.1
	Number of revolution	rev/min	Inverter 3,600 at 60Hz	Inverter 3,600 at 60Hz	Inverter 3,600 at 60Hz
	Motor Output	kW	5.3 + 5.3 + 5.3 + 4.2	5.3 + 5.3 + 5.3 + 4.2	5.3 + 5.3 + 5.3 + 5.3
	Starting Method		Direct On Line	Direct On Line	Direct On Line
	Oil Type		FVC71D(PVE)	FVC74D(PVE)	FVC77D(PVE)
	Oil Charge Amount	cc	(1 400 x 3 + 1 200) + (1 600 x 4)	(1 400 x 3 + 1 200) + (1 600 x 4)	(1 400 + 1 600) x 4
Heat Exchanger	Type	Stainless Steel Plate	Stainless Steel Plate	Stainless Steel Plate	
	Maximum Pressure Resistance	kgf/cm ²	45	45	
	Head Loss	kPa	30.1 + 30.1 + 30.1 + 15.8	30.1 + 30.1 + 30.1 + 28.6	30.1 + 30.1 + 30.1 + 30.1
	Rated Water Flow	LPM	192 + 192 + 192 + 96	192 + 192 + 192 + 135	192 + 192 + 192 + 192
Temp. range of	Cooling	10°C - 45°C(50°F - 116°F)	10°C - 45°C(50°F - 119°F)	10°C - 45°C(50°F - 122°F)	
	Heating	-5°C - 45°C(23°F - 116°F)	-5°C - 45°C(23°F - 119°F)	-5°C - 45°C(23°F - 122°F)	
Refrigerant Connecting Pipes	Liquid Pipes	mm(inch)	22.2(7/8)	22.2(7/8)	22.2(7/8)
	Low Pressure Gas Pipes	mm(inch)	53.98(2-1/8)	53.98(2-1/8)	53.98(2-1/8)
	High Pressure Gas Pipes	mm(inch)	44.5(1-3/4)	44.5(1-3/4)	44.5(1-3/4)
Water Connecting Pipes	Inlet	mm	PT 40 + PT 40 + PT 40 + PT40	PT 40 + PT 40 + PT 40 + PT 40	PT 40 + PT 40 + PT 40 + PT 40
	Outlet	mm	PT 40 + PT 40 + PT 40 + PT40	PT 40 + PT 40 + PT 40 + PT 40	PT 40 + PT 40 + PT 40 + PT 40
	Drain Outlet	mm	PT20 (3/4, External)	PT20 (3/4, External)	PT20 (3/4, External)
Dimensions (W x H x D)	mm	(755 x 997 x 500) x 4	(755 x 997 x 500) x 4	(755 x 997 x 500) x 4	
	inch	(29-23/32 x 39-1/4 x 19-11/16) x 4	(29-23/32 x 39-1/4 x 19-11/16) x 4	(29-23/32 x 39-1/4 x 19-11/16) x 4	
Net Weight	kg	(140 x 2) + (127 X 2)	(140 x 3) + (127 x 1)	140 x 4	
	lbs	(309 x 2) + (280 X 2)	(309 x 3) + (280 x 1)	309 x 4	
Transmission Cable (CVV-SB)	mm ²	1.0 - 1.5 x 5C	1.0 - 1.5 x 8C	1.0 - 1.5 x 11C	
Refrigerant	Name	R410A	R410A	R410A	
	Charge Amount	kg	5.8 + 5.8 + 3.0 + 3.0	3.0 + 3.0 + 3.0 + 5.8	3.0 + 3.0 + 3.0 + 3.0
	Control Device		EEV	EEV	EEV
Power Supply	Ø / V / Hz	6 / 380 - 415 / 50	9 / 380 - 415 / 50	12 / 380 - 415 / 50	
		6 / 380 / 60	9 / 380 / 60	12 / 380 / 60	
Sound Pressure Level	Cooling	dB(A)	60	61	57
	Heating	dB(A)	65	63	63
Sound Power Level	Cooling	dB(A)	74	75	71
	Heating	dB(A)	80	77	77

* This product contains Fluorinated Greenhouse Gases. (R410A)
 Note : 1. Capacities and Inputs are based on the following conditions
 - Cooling : Indoor temp. 27°C (80.6°F) DB / 19°C (66.2°F) WB, Water inlet temp. 30°C (86°F), Interconnecting piping length 7.5m, Level difference of zero
 - Heating : Indoor temp. 20°C (68°F) DB, Water inlet temp. 20°C (68°F)
 2. Capacities are net capacities
 3. Due to our policy of innovation some specifications may be changed without notification
 4. Add an anti freeze to circulation water when outside unit is operating under 10°C (50°F), and change the DIP switch on main PCB. (For more information on installation section.)

INDOOR UNITS

WALL MOUNTED UNIT / ROUND CASSETTE /
CEILING MOUNTED CASSETTE /
CEILING CONCEALED DUCT / FRESH AIR INTAKE UNIT /
FLOOR STANDING UNIT /
CEILING SUSPENDED UNIT, CEILING & FLOOR CONVERTIBLE UNIT /
CONSOLE & FLOOR STANDING UNIT / COMPATIBILITY /
FEATURE FUNCTIONS



INDOOR UNITS LINE-UP

kW		1.5	2.2	2.8	3.6	4.5	5.6	6.2	7.1	8.2	9.0	10.6	12.3	14.1	15.8	22.4	28.0
Type	Btu/h	5k	7k	9k	12k	15k	18k	21k	24k	28k	30k	36k	42k	48k	54k	76k	96k
4 th generation Wall Mounted Unit	Artcool Gallery 		●	●	●												
	Artcool Mirror 	●	●	●	●	●		●									
	Standard 	●	●	●	●	●		●		●	●						
4 th generation Ceiling Mounted Cassette	Round Cassette 								●			●		●			
	4 Way Cassette (570 x 570) 	●	●	●	●	●	●										
	4 Way Cassette (840 x 840) 								●	●	●	●	●	●	●		
	4 Way Cassette High Sensible (840 x 840) 		●	●	●	●	●		●	●		●	●				
	2 Way Cassette 			●	●		●		●								
	1 Way Cassette 		●	●	●		●		●								
4 th generation Ceiling Concealed Duct	Mid / High Statics 		●	●	●	●	●		●	●		●	●	●	●	●	●
	Low Statics 	●	●	●	●	●	●	●									
	High Sensible 		●	●	●	●	●		●	●		●	●	●			
4 th generation Fresh Air Intake Units 																●	●
4 th generation Ceiling & Floor Convertible Unit 				●	●												
4 th generation Ceiling Suspended Unit 							●		●			●	●				
4 th generation Console 		●	●	●	●												
4 th generation Floor Standing Unit	Floor Standing Unit with Case 		●	●	●	●	●		●								
	Floor Standing Unit without Case 		●	●	●	●	●		●								
4 th generation HYDRO KIT	Low Temperature 												●				●
	High Temperature 												●			●	
4 th generation Energy Recovery Ventilator with DX Coil	with Humidifier 				●				●		●						
	without Humidifier 				●				●		●						

1) If 4th generation indoor units are combined to 2nd generation indoor units, several functions are not available. More detailed information, refer to the "MULTI V Indoor units Compatibility Table"

INDOOR UNITS FEATURE OVERVIEW

Energy Monitoring	2 Set Point	Occupied / Unoccupied Scheduling Function	Group Control	Test Run (Cooling)	Test Run (Heating)	Model Information Monitoring	Auto Addressing	Refrigerant Leakage Detection	Thermo On / Off Range Setting (Cooling)	Thermo On / Off Range Setting (Heating)	Static Pressure 11 Step Control (Only for Ceiling Concealed Duct Type)	1 Point External Input (On / Off Control)	Filter Sign (Remaining Time)	Auto Restart Function Disable / Enable	Wi-Fi Ready
●	●	●	●	●	●	●	●	●	●	●		●	●	●	●
●	●	●	●	●	●	●	●	●	●	●		●	●	●	●
●	●	●	●	●	●	●	●	●	●	●		●	●	●	●
●	●	●	●	●	●	●	●	●	●	●		●	●	●	●
●	●	●	●	●	●	●	●	●	●	●		●	●	●	●
●	●	●	●	●	●	●	●	●	●	●		●	●	●	●
●	●	●	●	●	●	●	●	●	●	●		●	●	●	●
●	●	●	●	●	●	●	●	●	●	●		●	●	●	●
●	●	●	●	●	●	●	●	●	●	●		●	●	●	●
●	●	●	●	●	●	●	●	●	●	●		●	●	●	●
●	●	●	●	●	●	●	●	●	●	●		●	●	●	●
●	●	●	●	●	●	●	●	●	●	●		●	●	●	●
●	●	●	●	●	●	●	●	●	●	●		●	●	●	●
												●	●	●	●
												●	●	●	●

OUTDOOR UNITS

INDOOR UNITS

HOT WATER SOLUTION

VENTILATION SOLUTIONS

CONTROL SOLUTIONS

ACCESSORIES

WALL MOUNTED UNIT



Features & Benefits

- 6 Different Discharge Angles can be Programmed via the Remote Control
- Easily Detachable Full Surface Cover Helps Clean the Air Conditioner Flawlessly.
- Drain Pipe can be Easily Hidden from Sight.

Key Applications

- Retail
- Restaurant
- Office
- Hotel
- Multi-family Residence

	Wall Mounted Unit	Artcool Mirror	Artcool Gallery	Standard
Smart	Wi-Fi	○	○	○
Energy Efficiency	Energy Display	○	○	○
Fast Cooling & Heating	Jet Cool	○	○	○
	Auto Swing (up & down)	○	○	○
Health	Ionizer	○	-	-7.1kW Only
	Pre Filter	○	○	○
	Auto Cleaning	○	○	○
Comfort	Sleep Mode	○	○	○
	Timer (on / off)	○	○	○
	Timer (weekly)	○	○	○
	Two Thermistor Control	○	○	○
	Group Control	○	○	○

※ ○: Applied, - : Not applied

Wi-Fi Control

Control your air conditioners via using the smart internet devices as Android or iOS based smartphones. This advanced technology provides you the best convenience.

LG SmartThinQ

 Search "LG SmartThinQ" on Google market or Appstore then download the app.
LG SmartThinQ

Integrated Home Appliances Control

Control / Monitor all your LG appliances from one place.



Access your air conditioner anytime and from anywhere with a Wi-Fi equipped device and LG's exclusive control app, SmartThinQ.



Easy Registration and Log-in

Follow the easy set-up steps that will activate SmartThinQ's impressive feature.

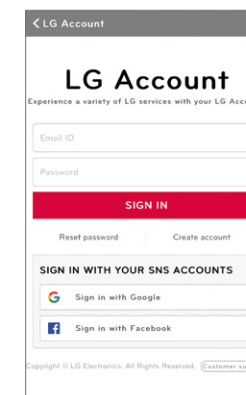

Wi-Fi Connectivity

Let's every member of your family choose their own preferred air conditioning temperature and fan speed, then save the settings in their app to run later. You can save the setting for each air conditioner as well.



* Can be controlled by multiple users, but not simultaneously

Simple operation for various functions

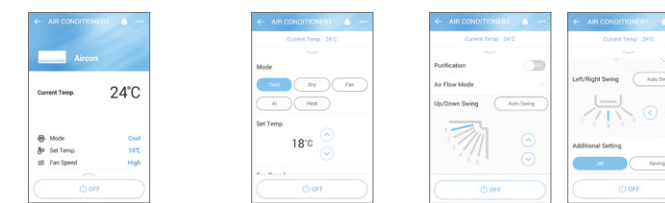

On/Off, Current Temp Mode, Set Temp Vane Control

Straight forward Management

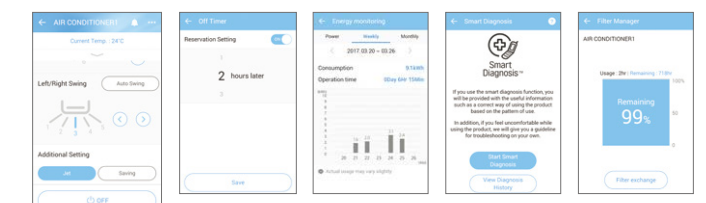

Reservation Energy Monitoring Smart Diagnosis Filter Management

WALL MOUNTED UNIT

Energy Display

LG's Energy Display panel monitors the amount of energy levels used. Save on energy consumption while enjoying the cooling by checking your energy level on the pane.

* Specifications may vary for each model.

Magic Display & Remote Control

With the push of a button on the remote control, indoor unit's LCD display shows the current and total energy use, thus making the users aware of reducing energy consumption.

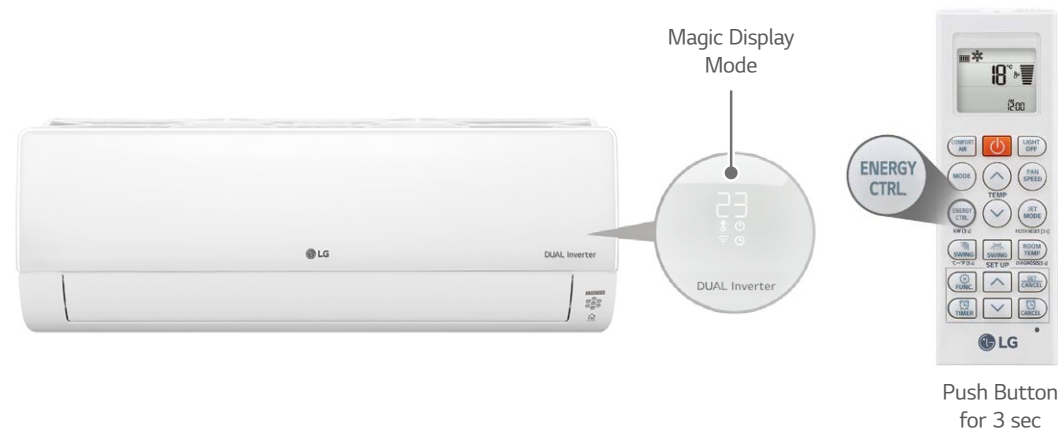

Normal Mode

Current Setting Temp



Electric Power

Displays Current Energy Use



Fan Speed

Display	Speed
F5	High
F4	Medium-High
F3	Medium
F2	Medium-Low
F1	Low

Sleep Mode



For example, setting 1hr

4 Way Swing

Cool air reaches out to the entire room regardless of where the air conditioner is installed.

* Specifications may vary for each model.

6-Step Vane, Control up to 70°

The vertical vane, which moves up and down, has 6 different settings including full swing.

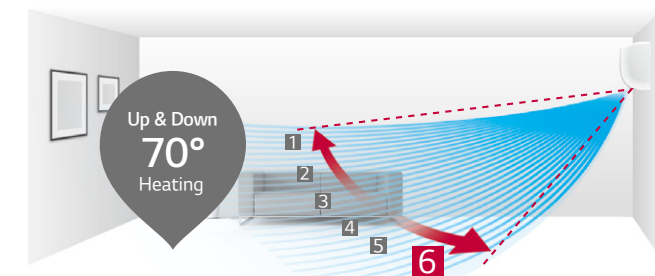

* Angle can be different from each model and working mode.

Control up to 100°

The louver can be adjusted by manual.

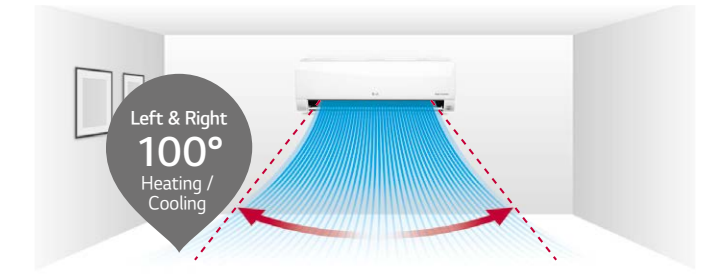

* Angle can be different from each model and working mode.

Easy and Simple Control

Airflow direction can be changed by LG ThinQ Wi-Fi app.

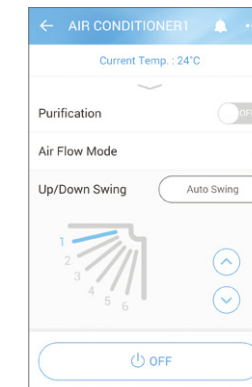

Up/Down Swing

Jet Cool

LG air conditioners provide optimized high-speed airflow, which can cool rooms faster while delivering cool air evenly in every direction.

* Specifications may vary for each model.
* Depending on the experimental conditions.

One Click "Jet Mode"

Reduces the temperature of outflowing air to 18°C for 30 minutes with just one click.



More Powerful Performance

By reducing the second vortex, which decreases airflow within the air outlet, and enlarging the fan size, the amount of airflow is increased to 13.0 CMM.



WALL MOUNTED UNIT

Ionizer PLUS

The powerful Ionizer protects you from bad odors and harmful and contagious particles in the air with over 3 million ions to sterilize not only the air passing through the air conditioner, but also surrounding surfaces for a safer, and cleaner environment.

* Specifications may vary for each model.
* Depending on the experimental conditions.

Sterilization and Deodorization (Utilizes Over 3 Million Ions)

Ionizer+ reduces harmful and contagious microscopic particles by infusing the air passing through the air conditioner with over 3 million ions.

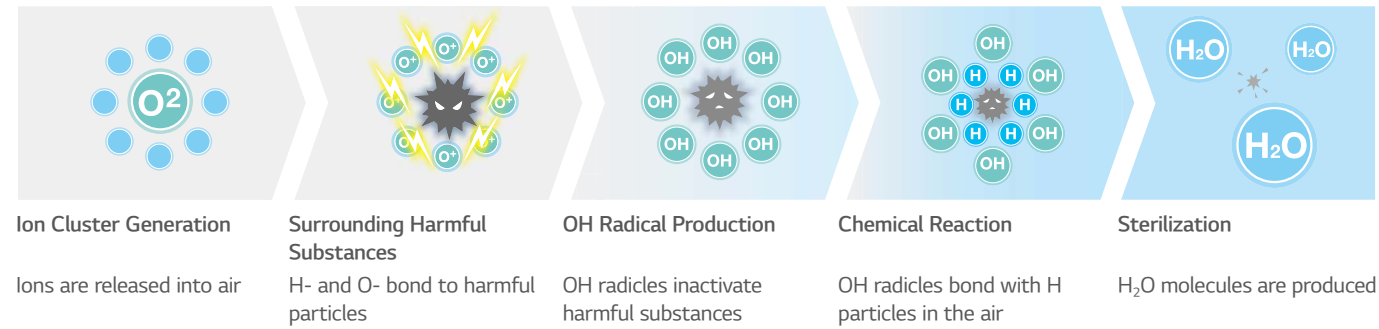

Sterilization Performance Evaluations

Sterilize Bacteria (E.coli colon bacillus) over 99.9% in 30 min.



* Test Conditions : Space : 52m³ Chamber / Temperature & Humidity : Normal / Bacteria : Staphylococcus Aureus

2.1 odor strength decrease in 60 minutes

An odor of measured as 2 European odor units (ouE/m³) or less indicates that the level of odor falls within permissible limits

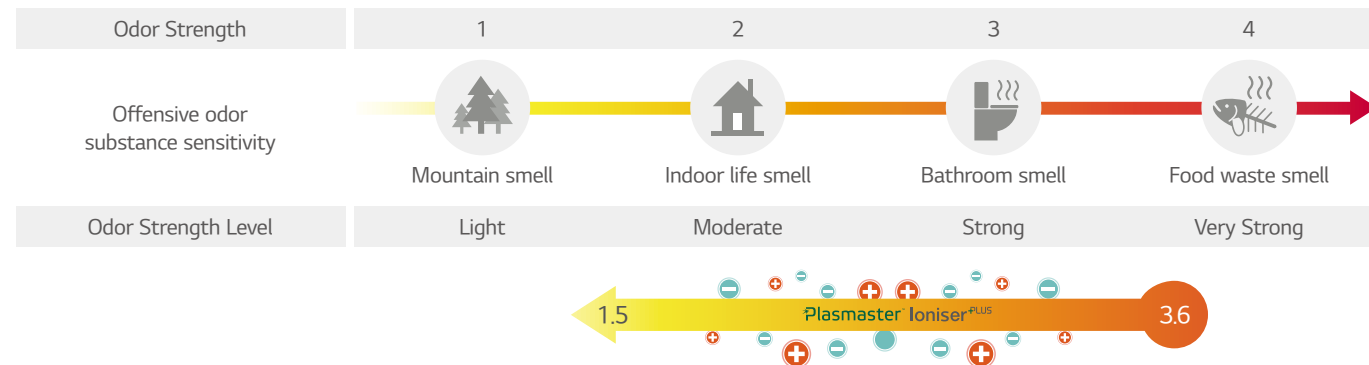

Odor strength reduce 3.6 → 1.5 / The Odor floating in the room as well as curtain and clothes.

Auto Cleaning

The interior of the air conditioner is maintained clean by drying off the heat exchanger, then sterilizing the interior once more.

Pain Point

The main cause of odor within air conditioners is mold and bacteria growing on the heat exchanger. These germs can spread when the heat exchanger is wet.



Cleans Filter with Regular Airflow

The comprehensive auto cleaning function prevents the formation of bacteria and mold on the heat exchanger, providing an enhancing environment.

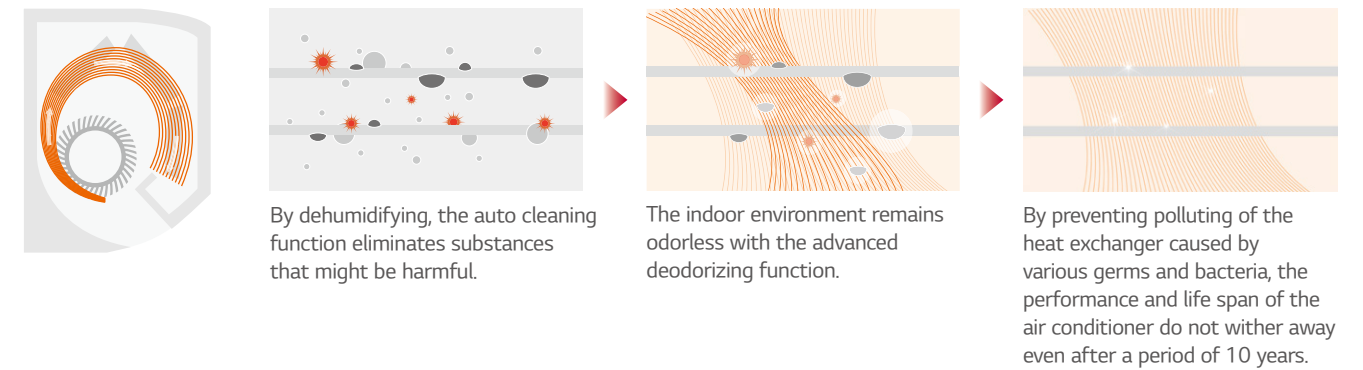

Removes Harmful Particles

Auto Cleaning provides clean air by preventing bacteria, mold and odors that can otherwise accumulate in an indoor unit.



WALL MOUNTED UNIT

Scheduled Operation

You can set the daily temperature, fan speed, the operation mode and automatic on/off time for two weeks. It will keep running on that time until cancelled by the user or after setting period

* This function is for wired remote controller only.
* Wired remote controller is need to be separately purchased.

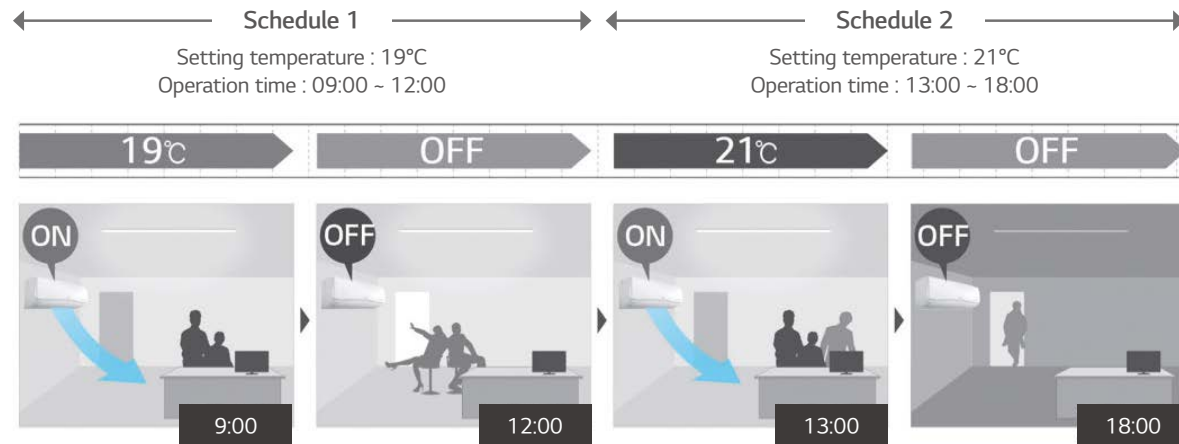

Two Thermistors Control

The indoor temperature can be checked using the thermistors in the remote controller as well as from the indoor unit. There may be a significant difference between ceiling and floor air temperature. Two thermistors can optimise indoor air temperature for a more comfortable environment.



Group Control

In case of group control, user can control much more function than conventional.

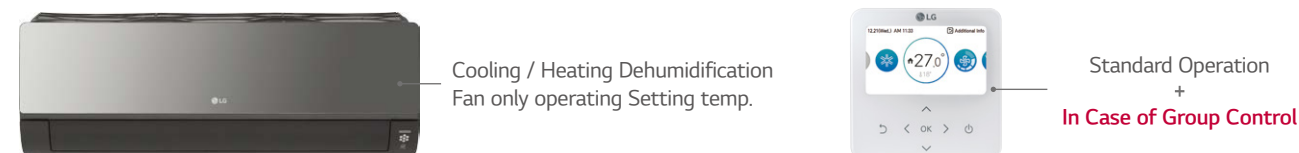

Quick & Easy Installation

LG air conditioner is designed for an easy and efficient installation, making possible to install several units in a short period of time

* Specifications may vary for each model.

One Simple Packing Box

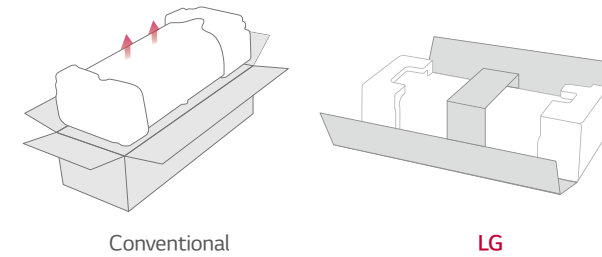

Installation Support Clip

A support clip creates adequate space between the wall and the unit for easier installation.

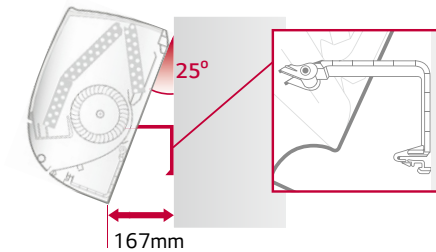

Detachable Bottom Cover

The air conditioner's bottom cover is detachable for easier installation and access.

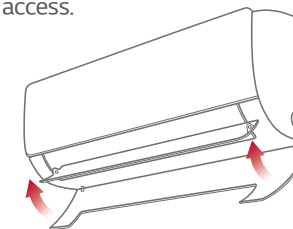

3 Way Flexible Installation

It is possible to install and connect the outdoor unit in 3 different ways (Left, Right, Back).

Back side view

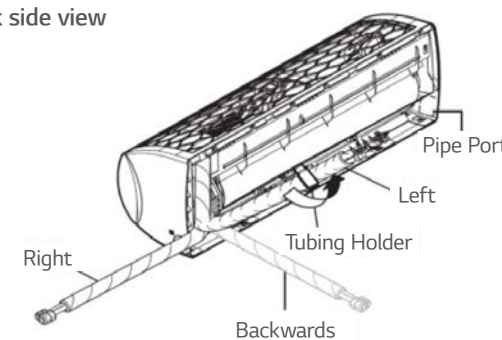

Installation Plate Improvement

LG's installation plate is larger and customized to reduce installation time.

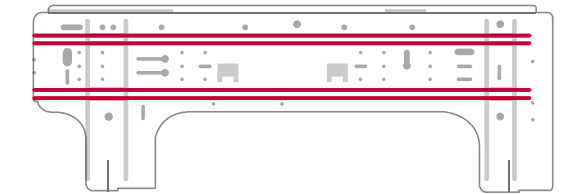

Wider Tubing Space

The space provided for tubing facilitates the whole installation process and hides the unorganized parts, making it appear clean and tidy.

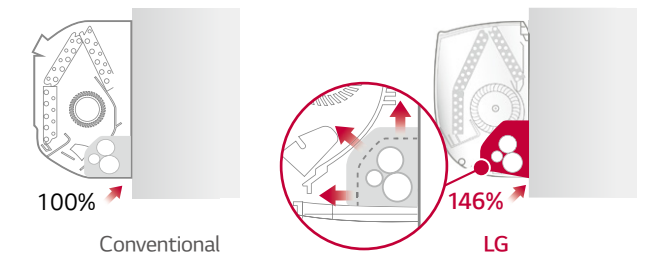

Quick button for running test

The test button is conveniently located and easy to find.

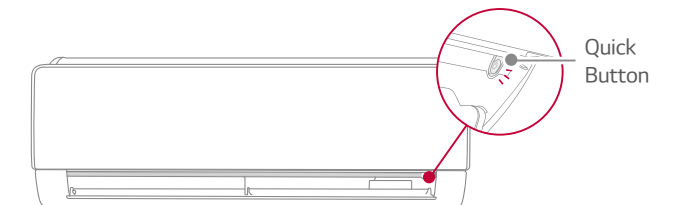

ARTCOOL MIRROR

ARNU05GSJR4 / ARNU07GSJR4 / ARNU09GSJR4
ARNU12GSJR4 / ARNU15GSJR4



Model	Unit	ARNU05GSJR4	ARNU07GSJR4	ARNU09GSJR4	ARNU12GSJR4	ARNU15GSJR4
Cooling Capacity	kW	1.6	2.2	2.8	3.6	4.5
Heating Capacity	kW	1.8	2.5	3.2	4.0	5.0
Power Input (H / M / L)	Nominal W	11 / 10 / 9	12 / 11 / 9	13 / 12 / 9	15 / 13 / 11	23 / 18 / 11
Exterior Color		Mirror(Black)	Mirror(Black)	Mirror(Black)	Mirror(Black)	Mirror(Black)
RAL Code		RAL 9005	RAL 9005	RAL 9005	RAL 9005	RAL 9005
Dimensions (W x H x D)	Body	mm 837 x 308 x 192	mm 837 x 308 x 192	mm 837 x 308 x 192	mm 837 x 308 x 192	mm 837 x 308 x 192
	Shipping	mm 909 x 383 x 256	mm 909 x 383 x 256	mm 909 x 383 x 256	mm 909 x 383 x 256	mm 909 x 383 x 256
Fan	Type	Cross Flow Fan	Cross Flow Fan	Cross Flow Fan	Cross Flow Fan	Cross Flow Fan
	Motor Output x Number	W x No. 30 x 1	30 x 1	30 x 1	30 x 1	30 x 1
	Air Flow Rate (H / M / L)	m ³ /min 6.8 / 6.5 / 5.9	7.2 / 6.8 / 5.9	7.8 / 7.2 / 5.9	8.5 / 7.8 / 6.8	10.5 / 9.5 / 6.8
	Motor type	BLDC	BLDC	BLDC	BLDC	BLDC
	Air Filter	Pre Filter	Pre Filter	Pre Filter	Pre Filter	Pre Filter
Pipe Connections	Liquid Side	mm (inch) Ø6.35 (1/4)	mm (inch) Ø6.35 (1/4)	mm (inch) Ø6.35 (1/4)	mm (inch) Ø6.35 (1/4)	mm (inch) Ø6.35 (1/4)
	Gas Side	mm (inch) Ø12.7 (1/2)	mm (inch) Ø12.7 (1/2)	mm (inch) Ø12.7 (1/2)	mm (inch) Ø12.7 (1/2)	mm (inch) Ø12.7 (1/2)
	Drain Pipe (Internal Dia.)	mm (inch) Ø16(5/8)	mm (inch) Ø16(5/8)	mm (inch) Ø16(5/8)	mm (inch) Ø16(5/8)	mm (inch) Ø16(5/8)
Weight	Body	kg 9.2	kg 9.2	kg 9.2	kg 9.2	kg 9.2
Sound Pressure Levels (H / M / L)	dB(A)	30 / 29 / 28	32 / 30 / 28	34 / 32 / 28	37 / 34 / 30	42 / 39 / 32
Sound Power Levels (H / M / L)	dB(A)	54 / 53 / 52	54 / 53 / 52	55 / 54 / 52	55 / 54 / 53	58 / 56 / 54
Power Supply	Ø, V, Hz	1, 220-240, 50	1, 220-240, 50	1, 220-240, 50	1, 220-240, 50	1, 220-240, 50
		1, 220, 60	1, 220, 60	1, 220, 60	1, 220, 60	1, 220, 60
Communication Cable	mm ² x No.	1.0 - 1.5 x 2C	1.0 - 1.5 x 2C	1.0 - 1.5 x 2C	1.0 - 1.5 x 2C	1.0 - 1.5 x 2C

* Nominal : Performance tested under EN14511

* Rated : Max power input allowed for fan motor

Note : 1. Capacities are based on the following conditions

- Cooling : Indoor temp. 27°C (80.6°F) DB / 19°C (66.2°F) WB, Outdoor temp. 35°C (95°F) DB / 24°C (75.2°F) WB, Interconnecting piping length 7.5m, Level difference of zero

- Heating : Indoor temp. 20°C (68°F) DB / 15°C (59°F) WB, Outdoor temp. 7°C (44.6°F) DB / 6°C (42.8°F) WB, Interconnecting piping length 7.5m, Level difference of zero

2. Due to our policy of innovation some specifications may be changed without notification

3. I.D : 'Internal Diameter'

Accessories

Chassis	ARNU05GSJR4	ARNU07GSJR4	ARNU09GSJR4	ARNU12GSJR4	ARNU15GSJR4
Drain Pump			-		
Cassette Cover			-		
Refrigerant Leakage Detector			PRLDNVSO		
EEV Kit			PRGK024A0		
Independent Power Module			PRIP0		
Robot Cleaner			-		
Pre Filter (washable / anti-fungus)			○		
Ion Generator			○		
CO ₂ Sensor			-		
Ventilation Kit			-		
IR Receiver			-		
Zone Controller			-		
Dry Contact (with additional accessory)			PDRYCB000 (1 point contact) PDRYCB300 (8 points for thermostat compatible) PDRYCB400 (2 points input) PDRYCB500 (Modbus)		
External Input (1 point)			○		
Wi-Fi			○		

※ ○ : Applied, - : Not applied

Option : Refer to model name in table

ARNU18GSKR4 / ARNU24GSKR4



Model	Unit	ARNU18GSKR4	ARNU24GSKR4
Cooling Capacity	kW	5.6	7.1
Heating Capacity	kW	6.3	7.5
Power Input (H / M / L)	Nominal W	32 / 26 / 16	39 / 26 / 16
Exterior Color		Mirror(Black)	Mirror(Black)
RAL Code		RAL 9005	RAL 9005
Dimensions (W x H x D)	Body	mm 998 x 345 x 212	mm 998 x 345 x 212
	Shipping	mm 1,080 x 422 x 281	mm 1,080 x 422 x 281
Fan	Type	Cross Flow Fan	Cross Flow Fan
	Motor Output x Number	W x No. 58 x 1	58 x 1
	Air Flow Rate (H / M / L)	m ³ /min 14.0 / 12.0 / 10.5	15.2 / 12.7 / 10.5
	Motor type	BLDC	BLDC
	Air Filter	Pre Filter	Pre Filter
Pipe Connections	Liquid Side	mm (inch) Ø6.35 (1/4)	mm (inch) Ø9.52(3/8)
	Gas Side	mm (inch) Ø12.7 (1/2)	mm (inch) Ø15.88(5/8)
	Drain Pipe (Internal Dia.)	mm (inch) Ø16(5/8)	mm (inch) Ø16(5/8)
Weight	Body	kg 13.4	kg 13.4
Sound Pressure Levels (H / M / L)	dB(A)	43 / 39 / 34	46 / 41 / 34
Sound Power Levels (H / M / L)	dB(A)	63 / 57 / 54	65 / 60 / 54
Power Supply	Ø, V, Hz	1, 220-240, 50	1, 220-240, 50
		1, 220, 60	1, 220, 60
Communication Cable	mm ² x No.	1.0 - 1.5 x 2C	1.0 - 1.5 x 2C

* Nominal : Performance tested under EN14511

* Rated : Max power input allowed for fan motor

Note : 1. Capacities are based on the following conditions

- Cooling : Indoor temp. 27°C (80.6°F) DB / 19°C (66.2°F) WB, Outdoor temp. 35°C (95°F) DB / 24°C (75.2°F) WB, Interconnecting piping length 7.5m, Level difference of zero

- Heating : Indoor temp. 20°C (68°F) DB / 15°C (59°F) WB, Outdoor temp. 7°C (44.6°F) DB / 6°C (42.8°F) WB, Interconnecting piping length 7.5m, Level difference of zero

2. Due to our policy of innovation some specifications may be changed without notification

3. I.D : 'Internal Diameter'

Accessories

Chassis	ARNU18GSKR4	ARNU24GSKR4
Drain Pump		-
Cassette Cover		-
Refrigerant Leakage Detector		PRLDNVSO
EEV Kit		PRGK024A0
Independent Power Module		PRIP0
Robot Cleaner		-
Pre Filter (washable / anti-fungus)		○
Ion Generator		○
CO ₂ Sensor		-
Ventilation Kit		-
IR Receiver		-
Zone Controller		-
Dry Contact (with additional accessory)		PDRYCB000 (1 point contact) PDRYCB300 (8 points for thermostat compatible) PDRYCB400 (2 points input) PDRYCB500 (Modbus)
External Input (1 point)		○
Wi-Fi		○

※ ○ : Applied, - : Not applied

Option : Refer to model name in table

ARTCOOL GALLERY

ARNU07GSF14 / ARNU09GSF14 / ARNU12GSF14

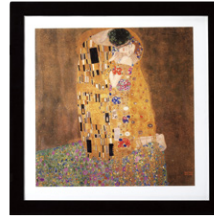

Model	Unit	ARNU07GSF14	ARNU09GSF14	ARNU12GSF14
Cooling Capacity	kW	2.2	2.8	3.6
Heating Capacity	kW	2.5	3.2	4.0
Power Input (H / M / L)	Nominal	28 / 16 / 10	28 / 16 / 10	32 / 20 / 12
	W			
Dimensions (W x H x D)	Body	600 x 600 x 146	600 x 600 x 146	600 x 600 x 146
	Shipping	685 x 670 x 215	685 x 670 x 215	685 x 670 x 215
Fan	Type	Turbo Fan	Turbo Fan	Turbo Fan
	Motor Output x Number	30 x 1	30 x 1	30 x 1
	Air Flow Rate (H / M / L)	8.1 / 6.3 / 4.2	8.1 / 6.3 / 4.2	9.3 / 7.7 / 6.0
	Motor type	BLDC	BLDC	BLDC
Air Filter		Pre Filter	Pre Filter	Pre Filter
Pipe Connections	Liquid Side	mm (inch)	Ø6.35(1/4)	Ø6.35(1/4)
	Gas Side	mm (inch)	Ø12.7(1/2)	Ø12.7(1/2)
	Drain Pipe (Internal Dia.)	mm (inch)	Ø12(15/32)	Ø12(15/32)
Weight	Body	kg	15.0	15.0
Sound Pressure Levels (H / M / L)		dB(A)	38 / 32 / 27	44 / 38 / 32
Sound Power Levels (H / M / L)		dB(A)	48 / 46 / 41	54 / 46 / 38
Power Supply	Ø, V, Hz	1, 220-240, 50	1, 220-240, 50	1, 220-240, 50
		1, 220, 60	1, 220, 60	1, 220, 60
Communication Cable	mm ² x No.	1.0-1.5 x 2C	1.0-1.5 x 2C	1.0-1.5 x 2C

* Nominal : Performance tested under EN14511

* Rated : Max power input allowed for fan motor

Note : 1. Capacities are based on the following conditions

- Cooling : Indoor temp. 27°C (80.6°F) DB / 19°C (66.2°F) WB, Outdoor temp. 35°C (95°F) DB / 24°C (75.2°F) WB, Interconnecting piping length 7.5m, Level difference of zero
- Heating : Indoor temp. 20°C (68°F) DB / 15°C (59°F) WB, Outdoor temp. 7°C (44.6°F) DB / 6°C (42.8°F) WB, Interconnecting piping length 7.5m, Level difference of zero
- 2. Due to our policy of innovation some specifications may be changed without notification
- 3. I.D : 'Internal Diameter'

Accessories

Chassis	ARNU07GSF14	ARNU09GSF14	ARNU12GSF14
Drain Pump		-	
Cassette Cover		-	
Refrigerant Leakage Detector		PRLDNVSO	
EEV Kit		PRGK024A0	
Independent Power Module		PRIP0	
Robot Cleaner		-	
Pre Filter (washable / anti-fungus)		○	
Ion Generator		-	
CO ₂ Sensor		-	
Ventilation Kit		-	
IR Receiver		-	
Zone Controller		-	
Dry Contact (with additional accessory)		PDRYCB000 (1 point contact) PDRYCB300 (8 points for thermostat compatible) PDRYCB400 (2 points input) PDRYCB500 (Modbus)	
External Input (1 point)		○	
Wi-Fi		PWFMD200 ¹⁾	

※ ○ : Applied, - : Not applied

Option : Refer to model name in table

1) External installation only

STANDARD

ARNU05GSJ*4 / ARNU07GSJ*4 / ARNU09GSJ*4 / ARNU12GSJ*4 / ARNU15GSJ*4



Model	Unit	ARNU05GSJ*4	ARNU07GSJ*4	ARNU09GSJ*4	ARNU12GSJ*4	ARNU15GSJ*4	
Cooling Capacity	kW	1.6	2.2	2.8	3.6	4.5	
Heating Capacity	kW	1.8	2.5	3.2	4.0	5.0	
Power Input (H / M / L)	Nominal	11 / 10 / 9	12 / 11 / 9	13 / 12 / 9	15 / 13 / 11	23 / 18 / 11	
	W						
Exterior Color		White	White	White	White	White	
RAL Code		RAL 9016	RAL 9016	RAL 9016	RAL 9016	RAL 9016	
Dimensions (W x H x D)	Body	mm	818 x 316 x 189	818 x 316 x 189	818 x 316 x 189	818 x 316 x 189	
	Shipping	mm	892 x 381 x 249	892 x 381 x 249	892 x 381 x 249	892 x 381 x 249	
Fan	Type		Cross Flow Fan	Cross Flow Fan	Cross Flow Fan	Cross Flow Fan	
	Motor Output x Number	W x No.	30 x 1	30 x 1	30 x 1	30 x 1	
	Air Flow Rate (H / M / L)	m ³ /min	6.8 / 6.5 / 5.9	7.2 / 6.8 / 5.9	7.8 / 7.2 / 5.9	8.5 / 7.8 / 6.8	10.5 / 9.5 / 6.8
	Motor type		BLDC	BLDC	BLDC	BLDC	BLDC
Air Filter		Pre Filter	Pre Filter	Pre Filter	Pre Filter	Pre Filter	
Pipe Connections	Liquid Side	mm (inch)	Ø6.35 (1/4)	Ø6.35 (1/4)	Ø6.35 (1/4)	Ø6.35 (1/4)	
	Gas Side	mm (inch)	Ø12.7 (1/2)	Ø12.7 (1/2)	Ø12.7 (1/2)	Ø12.7 (1/2)	
	Drain Pipe (Internal Dia.)	mm (inch)	Ø16(5/8)	Ø16(5/8)	Ø16(5/8)	Ø16(5/8)	
Weight	Body	kg	8.4	8.4	8.4	8.4	
Sound Pressure Levels (H / M / L)		dB(A)	30 / 29 / 28	32 / 30 / 28	34 / 32 / 28	37 / 34 / 30	42 / 39 / 32
Sound Power Levels (H / M / L)		dB(A)	54 / 53 / 52	54 / 53 / 52	55 / 54 / 52	55 / 54 / 53	58 / 56 / 54
Power Supply	Ø, V, Hz	1, 220-240, 50	1, 220-240, 50	1, 220-240, 50	1, 220-240, 50	1, 220-240, 50	
		1, 220, 60	1, 220, 60	1, 220, 60	1, 220, 60	1, 220, 60	
Communication Cable	mm ² x No.	1.0 - 1.5 x 2C	1.0 - 1.5 x 2C	1.0 - 1.5 x 2C	1.0 - 1.5 x 2C	1.0 - 1.5 x 2C	

* Nominal : Performance tested under EN14511

* Rated : Max power input allowed for fan motor

Note : 1. Capacities are based on the following conditions

- Cooling : Indoor temp. 27°C (80.6°F) DB / 19°C (66.2°F) WB, Outdoor temp. 35°C (95°F) DB / 24°C (75.2°F) WB, Interconnecting piping length 7.5m, Level difference of zero
- Heating : Indoor temp. 20°C (68°F) DB / 15°C (59°F) WB, Outdoor temp. 7°C (44.6°F) DB / 6°C (42.8°F) WB, Interconnecting piping length 7.5m, Level difference of zero
- 2. Due to our policy of innovation some specifications may be changed without notification
- 3. I.D : 'Internal Diameter'

* : N or C can be applied which has little bit different shape of panel.

Accessories

Chassis	ARNU05GSJ*4	ARNU07GSJ*4	ARNU09GSJ*4	ARNU12GSJ*4	ARNU15GSJ*4
Drain Pump			-		
Cassette Cover			-		
Refrigerant Leakage Detector			PRLDNVSO		
EEV Kit			PRGK024A0		
Independent Power Module			PRIP0		
Robot Cleaner			-		
Pre Filter (washable / anti-fungus)			○		
Ion Generator			○		
CO ₂ Sensor			-		
Ventilation Kit			-		
IR Receiver			-		
Zone Controller			-		
Dry Contact (with additional accessory)			PDRYCB000 (1 point contact) PDRYCB300 (8 points for thermostat compatible) PDRYCB400 (2 points input) PDRYCB500 (Modbus)		
External Input (1 point)			○		
Wi-Fi			○		

※ ○ : Applied, - : Not applied

Option : Refer to model name in table

STANDARD

ARNU18GSK*4 / ARNU24GSK*4



Model	Unit	ARNU18GSK*4	ARNU24GSK*4
Cooling Capacity	kW	5.6	7.1
Heating Capacity	kW	6.3	7.5
Power Input (H / M / L)	Nominal W	32 / 26 / 16	39 / 26 / 16
Exterior Color		White	White
RAL Code		RAL 9016	RAL 9016
Dimensions (W x H x D)	Body mm	975 x 354 x 209	975 x 354 x 209
	Shipping mm	1,063 x 420 x 274	1,063 x 420 x 274
Fan	Type	Cross Flow Fan	Cross Flow Fan
	Motor Output x Number	W x No.	58 x 1
	Air Flow Rate (H / M / L)	m ³ /min	14.0 / 12.0 / 10.5
	Motor type		BLDC
Air Filter		Pre Filter	Pre Filter
Pipe Connections	Liquid Side mm (inch)	Ø6.35 (1/4)	Ø9.52(3/8)
	Gas Side mm (inch)	Ø12.7 (1/2)	Ø15.88(5/8)
	Drain Pipe (Internal Dia.) mm (inch)	Ø16(5/8)	Ø16(5/8)
Weight	Body kg	12.2	12.2
Sound Pressure Levels (H / M / L)	dB (A)	43 / 39 / 34	46 / 41 / 34
Sound Power Levels (H / M / L)	dB (A)	63 / 57 / 54	65 / 60 / 54
Power Supply	Ø, V, Hz	1, 220-240, 50	1, 220-240, 50
Communication Cable	mm ² x No.	1.0 - 1.5 x 2C	1.0 - 1.5 x 2C

* Nominal : Performance tested under EN14511

* Rated : Max power input allowed for fan motor

Note : 1. Capacities are based on the following conditions

- Cooling : Indoor temp. 27°C (80.6°F) DB / 19°C (66.2°F) WB, Outdoor temp. 35°C (95°F) DB / 24°C (75.2°F) WB, Interconnecting piping length 7.5m, Level difference of zero

- Heating : Indoor temp. 20°C (68°F) DB / 15°C (59°F) WB, Outdoor temp. 7°C (44.6°F) DB / 6°C (42.8°F) WB, Interconnecting piping length 7.5m, Level difference of zero

2. Due to our policy of innovation some specifications may be changed without notification

3. I.D : 'Internal Diameter'

* : N or C can be applied which has little bit different shape of panel.

Accessories

Chassis	ARNU18GSK*4	ARNU24GSK*4
Drain Pump		-
Cassette Cover		-
Refrigerant Leakage Detector		PRLDNVS0
EEV Kit		PRGK024A0
Independent Power Module		PRIP0
Robot Cleaner		-
Pre Filter (washable / anti-fungus)		○
Ion Generator		○
CO ₂ Sensor		-
Ventilation Kit		-
IR Receiver		-
Zone Controller		-
Dry Contact (with additional accessory)		PDRYCB000 (1 point contact) PDRYCB300 (8 points for thermostat compatible) PDRYCB400 (2 points input) PDRYCB500 (Modbus)
External Input (1 point)		○
Wi-Fi		○

※ ○ : Applied, - : Not applied

Option : Refer to model name in table

ARNU30GSVA4 / ARNU36GSVA4



Model	Unit	ARNU30GSVA4	ARNU36GSVA4
Cooling Capacity	kW	8.8	10.4
Heating Capacity	kW	9.4	10.8
Power Input (H / M / L)	Nominal W	54 / 43 / 31	85 / 51 / 36
Exterior Color		White	White
RAL Code		RAL 9016	RAL 9016
Dimensions (W x H x D)	Body mm	1,190 x 346 x 265	1,190 x 346 x 265
	Shipping mm	1,265 x 432 x 335	1,265 x 432 x 335
Fan	Type	Cross Flow Fan	Cross Flow Fan
	Motor Output x Number	W x No.	113 x 1
	Air Flow Rate (H / M / L)	m ³ /min	23.0 / 20.0 / 17.0
	Motor type		BLDC
Air Filter		Pre Filter	Pre Filter
Pipe Connections	Liquid Side mm (inch)	Ø9.52 (3/8)	Ø9.52 (3/8)
	Gas Side mm (inch)	Ø15.88 (5/8)	Ø15.88 (5/8)
	Drain Pipe (Internal Dia.) mm (inch)	Ø16(5/8)	Ø16(5/8)
Weight	Body kg	16.6	16.6
Sound Pressure Levels (H / M / L)	dB (A)	49 / 44 / 42	52 / 47 / 43
Power Supply	Ø, V, Hz	1, 220-240, 50	1, 220-240, 50
Communication Cable	mm ² x No.	1.0 - 1.5 x 2C	1.0 - 1.5 x 2C

* Nominal : Performance tested under EN14511

* Rated : Max power input allowed for fan motor

Note : 1. Capacities are based on the following conditions

- Cooling : Indoor temp. 27°C (80.6°F) DB / 19°C (66.2°F) WB, Outdoor temp. 35°C (95°F) DB / 24°C (75.2°F) WB, Interconnecting piping length 7.5m, Level difference of zero

- Heating : Indoor temp. 20°C (68°F) DB / 15°C (59°F) WB, Outdoor temp. 7°C (44.6°F) DB / 6°C (42.8°F) WB, Interconnecting piping length 7.5m, Level difference of zero

2. Due to our policy of innovation some specifications may be changed without notification

3. I.D : 'Internal Diameter'

Accessories

Chassis	ARNU30GSVA4	ARNU36GSVA4
Drain Pump		-
Cassette Cover		-
Refrigerant Leakage Detector		PRLDNVS0
EEV Kit		-
Independent Power Module		PRIP0
Robot Cleaner		-
Pre Filter (washable / anti-fungus)		○
Ion Generator		-
CO ₂ Sensor		-
Ventilation Kit		-
IR Receiver		-
Zone Controller		-
Dry Contact (with additional accessory)		PDRYCB000 (1 point contact) PDRYCB300 (8 points for thermostat compatible) PDRYCB400 (2 points input) PDRYCB500 (Modbus)
External Input (1 point)		○
Wi-Fi		PWFMD200 ¹⁾

※ ○ : Applied, - : Not applied

Option : Refer to model name in table

1) External installation only

ROUND CASSETTE



Features & Benefits

- Premium design to match your interior space
- Pleasant airflow for optimal comfort
- Air purification
- Improved and simple installation

Key Applications

- Retail
- School
- Office
- Hotel
- Dormitory
- Restaurant

Installation

Minimal exposure of installations

Pipes are brought together in one place to minimize exposure. Hanger covers hide installations to add a clean, sophisticated look. (This product can only be installed on an open ceiling)

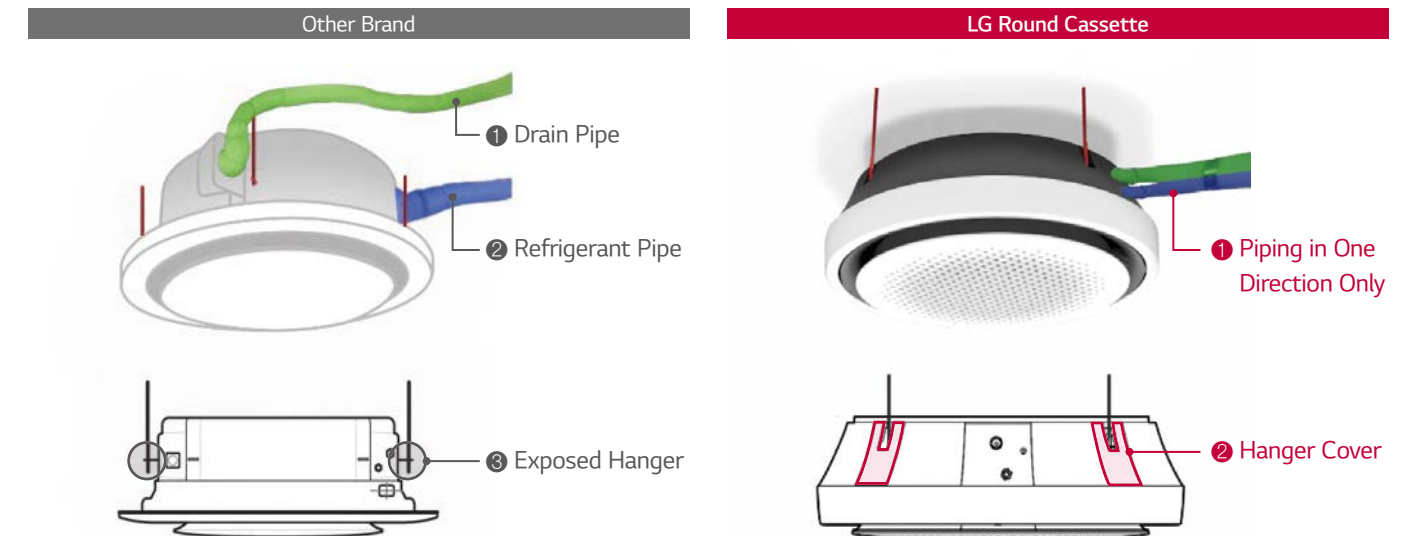

Comfort

Perfect Round Flow

Perfect round flow without blind spots. (This product can only be installed on an open ceiling)



ROUND CASSETTE

Comfort

Visible, Intuitive Airflow

With crystal vein for 6-step precision control, you can send cool / heated air wherever you want.

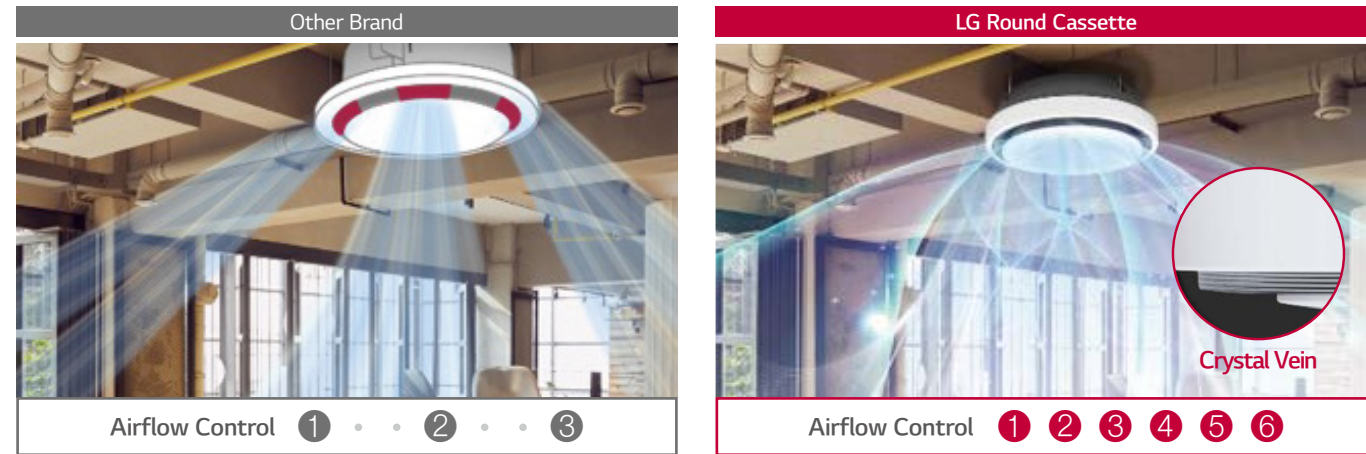

ARNU24GYA4 / ARNU36GYA4 / ARNU48GYA4



30% Faster in Cooling

With greater airflow, it gets cooler 30% faster, spreading cool air evenly without missing a spot.

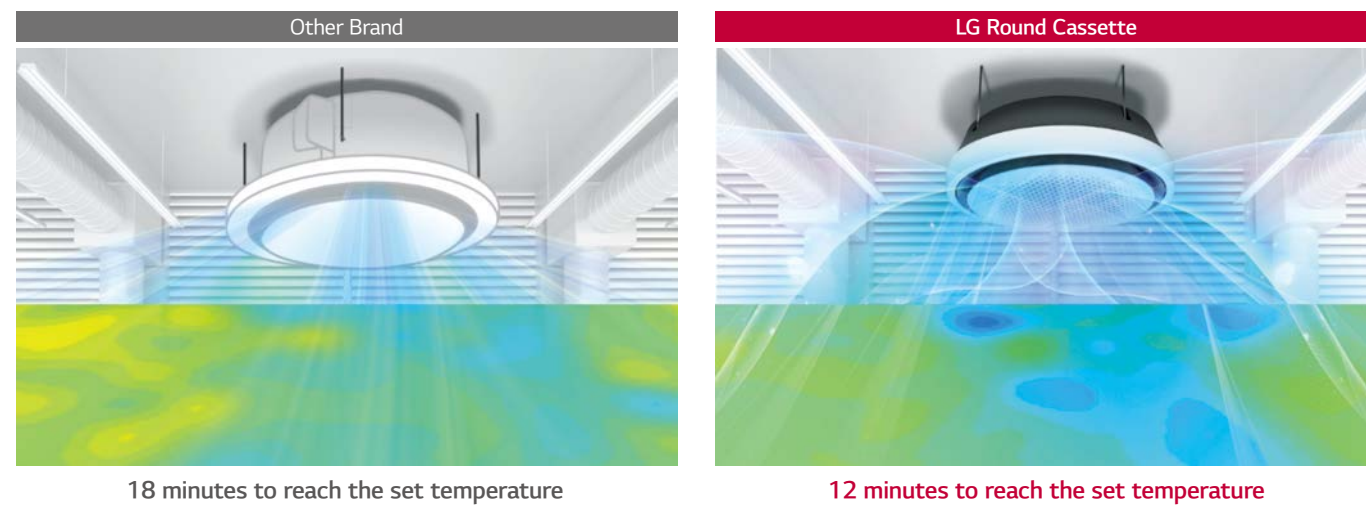

Model	Unit	ARNU24GYA4	ARNU36GYA4	ARNU48GYA4
Cooling Capacity	kW	7.2	11.0	14.5
Heating Capacity	kW	8.1	12.4	16.3
Power Input	Nominal	55	90	120
	Rated	120	120	120
Power Supply	∅, V, Hz	1, 220-240, 50	1, 220-240, 50	1, 220-240, 50
		1, 220, 60	1, 220, 60	1, 220, 60
AIR Flow rate	Cooling	m ³ /min (H / M / L) 22 / 21 / 19	27 / 24 / 21	32 / 28 / 23
	Heating	m ³ /min (H / M / L) 22 / 21 / 19	27 / 24 / 21	32 / 28 / 23
Sound Pressure	dBA (H / M / L)	39 / 37 / 34	43 / 39 / 37	47 / 44 / 39
Sound Power	dBA (H / M / L)	Not confirmed	Not confirmed	Not confirmed
Dimensions (W x H x D)	Body	mm 1,050 x 330 x 1,050	1,050 x 330 x 1,050	1,050 x 330 x 1,050
Net Weight	Body	kg 30	30	30
Pipe Connections	Liquid Side	mm 9.52	9.52	9.52
	Gas Side	mm 15.88	15.88	15.88
	Drain Pipe	mm 32	32	32

* Available from June 2019
 * Panel integrated product
 * This product can only be installed on an open ceiling

Clean Air

Powerful and Convenient 5-step Air Purification

With the semi-permanent 5-step air filter, you don't have to worry about maintenance cost anymore.



CEILING MOUNTED CASSETTE



Features & Benefits

- Human Detection Control Allowing Energy Savings Through "Saving Operation" & Comfort Through "Wind Direction Operation"
- New Multi-functional 4 Way Cassette Panel for Large Sizes with Aesthetic Shape
- The Independent Vane Operation Feature Allows User to Control Vanes by Desired and Perceptible Comfort Flow

Key Applications

- Retail
- School
- Office
- Hotel
- Dormitory
- Restaurant

Cassette		4 Way	2 Way	1 Way
Smart	Wi-Fi	○	○	○
Energy Efficiency	Human Detect Sensor	○	-	-
Health	Auto Cleaning	-	○	-
Comfort	Drain Pump	○	○	○
	Sleep Mode	○	○	○
	Timer (on / off)	○	○	○
	Timer (weekly)	○	○	○
	Two Thermistor Control	○	○	○
	Group Control	○	○	○

※ ○ : Applied, - : Not applied

Wi-Fi Control

Control your air conditioners via using the smart internet devices as Android or iOS based smartphones. This advanced technology provides you the best convenience.

LG SmartThinQ

 Search "LG SmartThinQ" on Google market or Appstore then download the app.
LG SmartThinQ

Access your air conditioner anytime and from anywhere

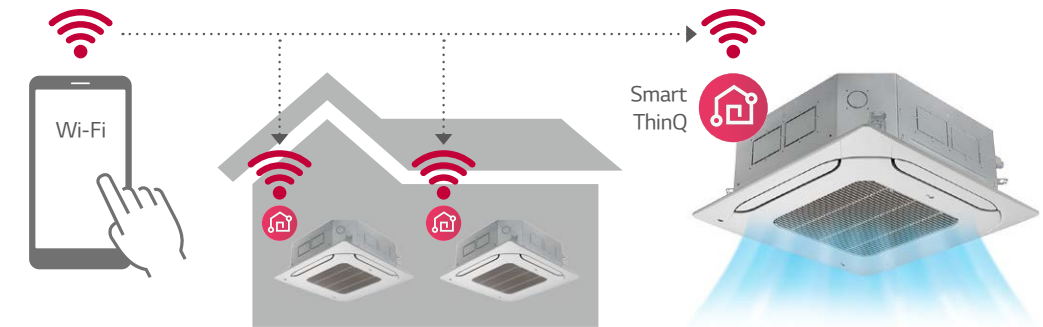

Easy Registration and Log-in

Follow the easy set-up steps that will activate SmartThinQ's impressive feature.

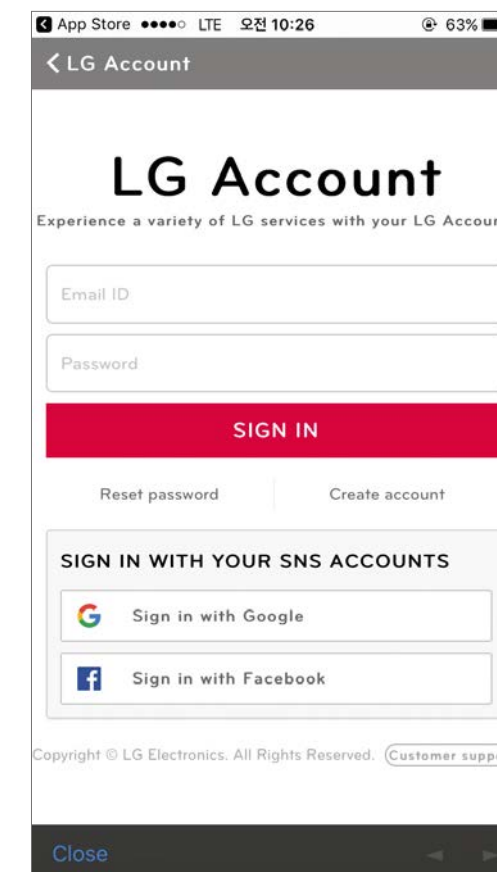

Wi-Fi Connectivity

Let's every member of your family choose their own preferred air conditioning temperature and fan speed, then save the settings in their app to run later. You can save the setting for each air conditioner as well.

Multiple Devices



Multi-Control



CEILING MOUNTED CASSETTE

Human Detect Sensor & Humidity Sensor

The interior of the air conditioner is maintained clean by drying off the heat exchanger, then sterilizing the interior once more.

Human detection sensor (PTVSMAO)

Humidity Sensor

Apply human detect sensor
 Apply vision sensor
 - Saving energy
 - Supply comfortable flow
 - Sensor is optional accessory only can be applied to PT-MCHW0

Comfortable and Power Saving Control based on Humidity
 Apply humidity sensor
 - Saving energy
 (To apply humidity sensor, new remote controller, PREMTB100 or PREMTBB10 is needed)

Direction control based on human motion

Air flow direction is controlled automatically by motion sensor that detects the activity of people every 10 seconds.

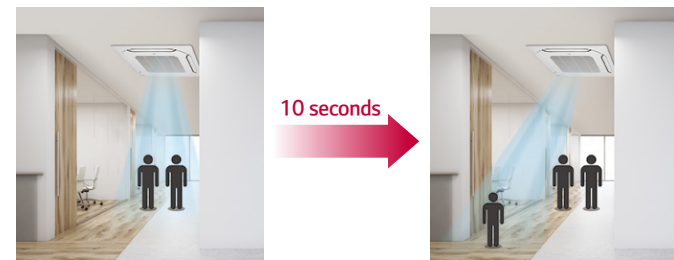

Detection range

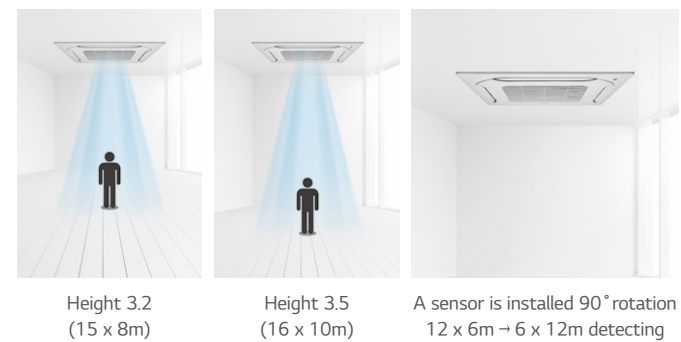

On/Off mode

The indoor unit automatically stops when detecting absence. It runs as the s us mode when sensing human body.

Sensing human body
 Undetected
 Sensing human body
 Undetected

ON OFF ON OFF

Energy saving ↓

Temperature control mode

Energy savings by automatically setting target temperature during absence. (5/10/15/30/60min)

24°C
 26°C
 28°C
 OFF
 Stop after blowing

Occupancy
 Absence 30min
 Absence 1hr
 Absence 1.5hr

ON OFF ON OFF

Energy saving ↓

Ionizer PLUS

The powerful Ionizer protects you from bad odors and harmful and contagious particles in the air with over 3 million ions to sterilize not only the air passing through the air conditioner, but also surrounding surfaces for a safer, and cleaner environment.

* Specifications may vary for each model.
 * Depending on the experimental conditions.

Sterilization and Deodorization (Utilizes Over 3 Million Ions)

Ionizer+ reduces harmful and contagious microscopic particles by infusing the air passing through the air conditioner with over 3 million ions.

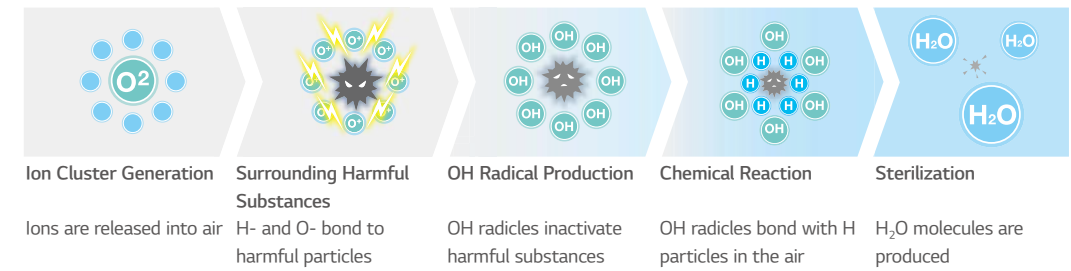

Sterilization Performance Evaluations

Sterilize Bacteria (E.coli colon bacillus) over 99.9% in 30 min.

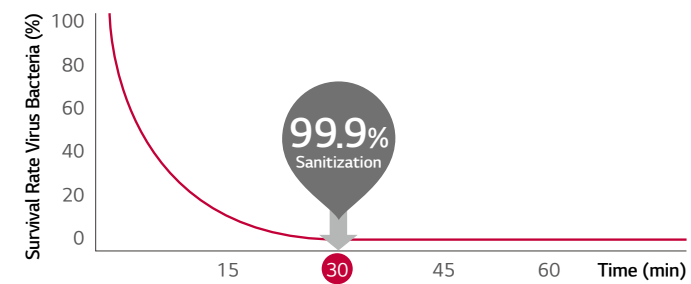

* Test Conditions : Space : 52m³ Chamber
 Temperature & Humidity : Normal
 Bacteria : Staphylococcus Aureus

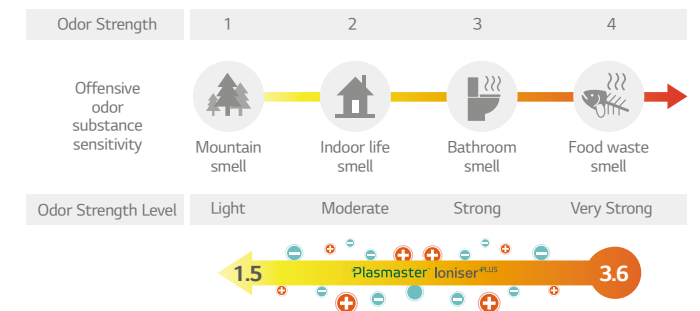

Odor strength reduce 3.6 → 1.5 / The Odor floating in the room as well as curtain and clothes.

Auto Cleaning

The interior of the air conditioner is maintained clean by drying off the heat exchanger, then sterilizing the interior once more

* Specifications may vary for each model.

Cleans Filter with Regular Airflow

The comprehensive auto cleaning function prevents the formation of bacteria and mold on the heat exchanger, providing an enhancing environment.

By dehumidifying, the auto cleaning function eliminates substances that might be harmful.

The indoor environment remains odorless with the advanced deodorizing function.

By preventing polluting of the heat exchanger caused by various germs and bacteria, the performance and life span of the air conditioner do not wither away even after a period of 10 years.

CEILING MOUNTED CASSETTE

Quick Control

4th Generation indoor unit offers rapid heating and cooling about 10times faster than conventional through communication mode change and improved communication speed.

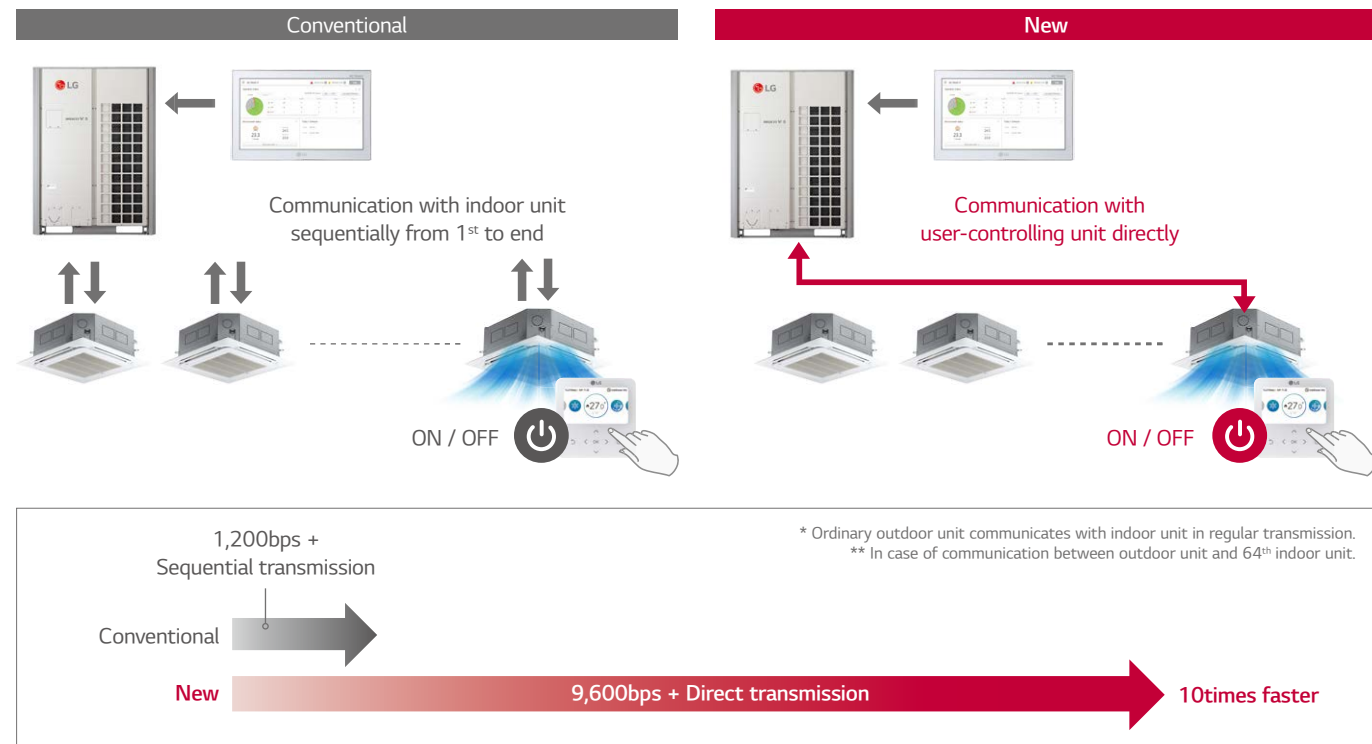

Group Control

In case of group control, user can control much more function than conventional

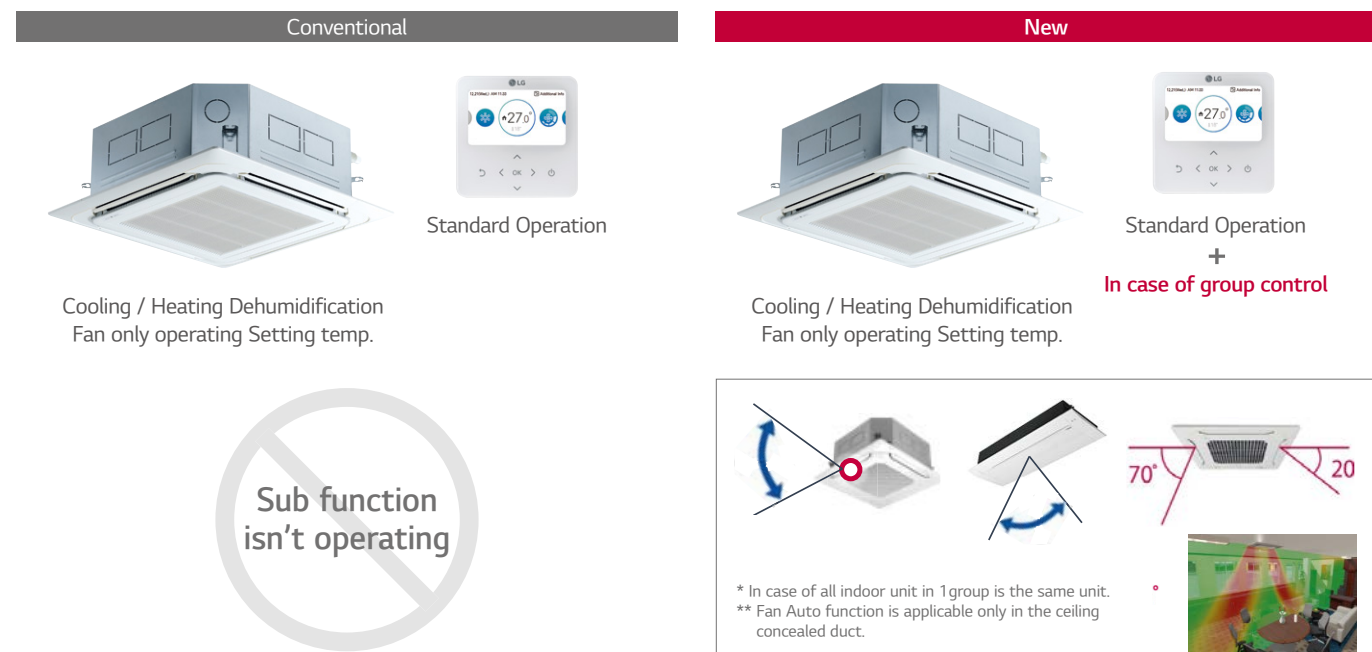

Independent Vane Control

The Independent Vane Operation feature uses separate motors, making it possible to control all four vanes independently.

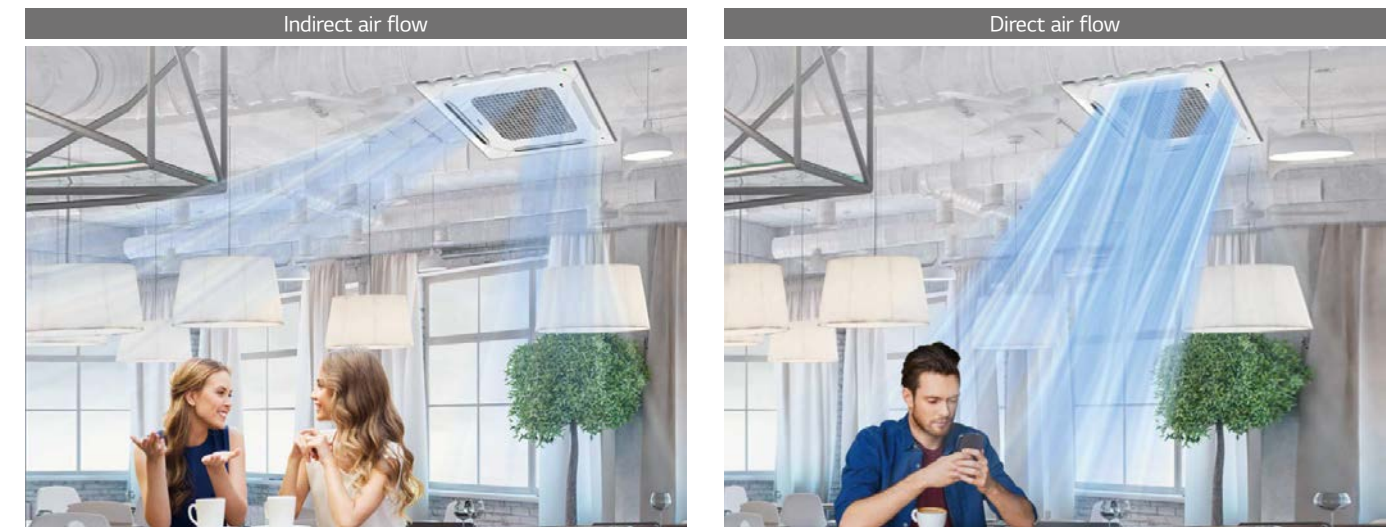

Auto Elevation Grille

The Independent Vane Operation feature uses separate motors, making it possible to control all four vanes independently.

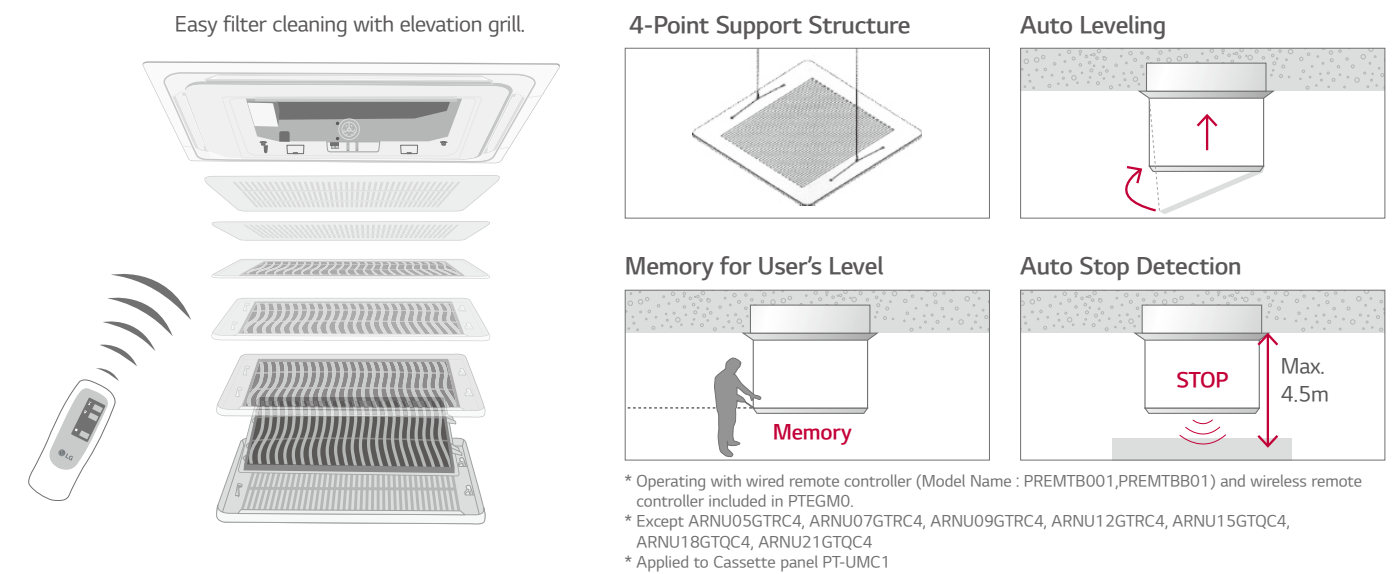

CEILING MOUNTED CASSETTE

High Ceiling Mode

High ceiling mode provides powerful cooling and heating up to 4.2m in height, from ceiling to floor.

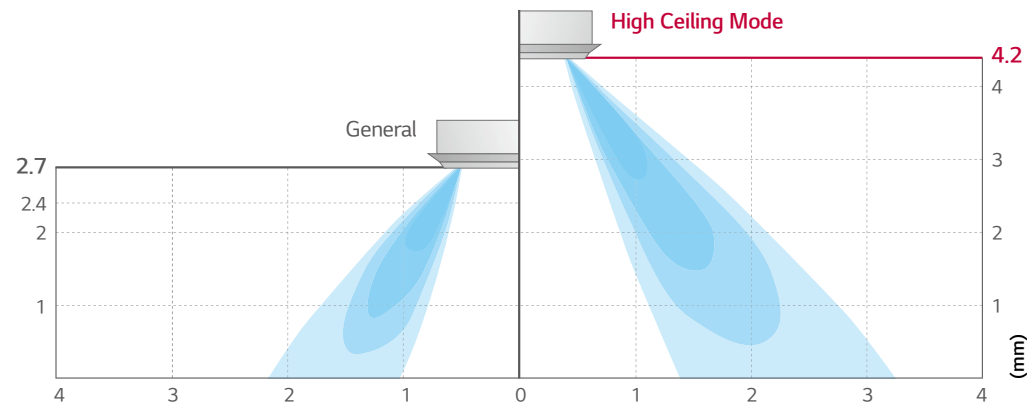

6-Step Vane Control

The Independent Vane Operation feature uses separate motors, making it possible to control all four vanes independently. There are 6 different steps to control air flow direction. Also 1 way cassette has a vane able to execute auto swing between left and right as 120 degree.

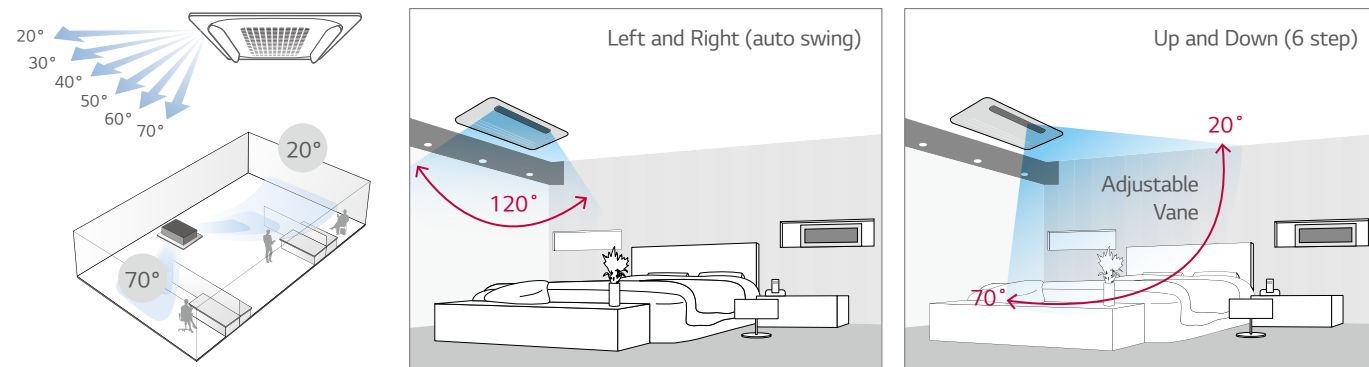

Minimized Height

LG 1 Way cassette isn't affected by installation environment. LG 1 Way cassette height is 132mm and duct is 190mm, so it can provide ideal solution for installation in limited space.

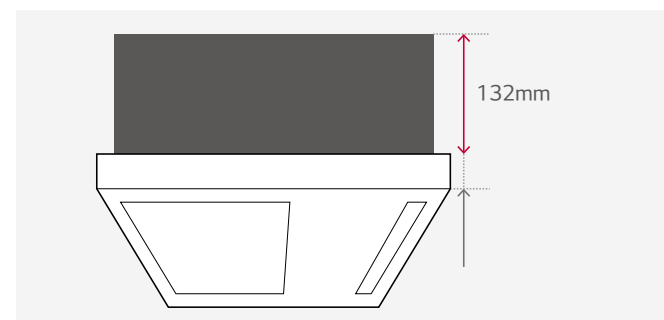

Size Comparison

(Unit : mm)

	A company	B company	LG
1 way cassette	215	230	132

Flexible Installation

The inspection access hole doesn't require additional ducted space allowing for simple installation scene to be possible.

1 Way cassette

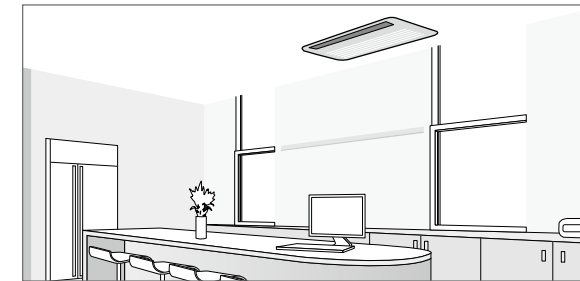

Duct

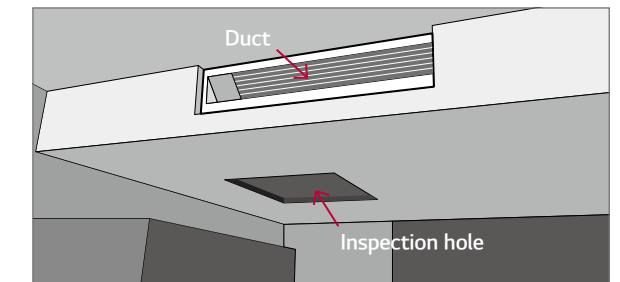

Compact and Stylish Design

New 4 Way cassette panel adapted unibody shape and matching with into the ceiling, Panel size is fit into the ceiling tile

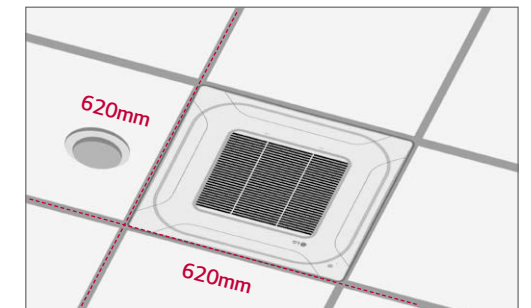
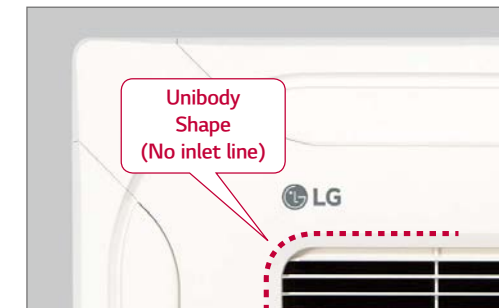

Compact Size

The indoor unit with slim and compact dimensions has reduced the restriction which enables successful installation in vario us spaces.

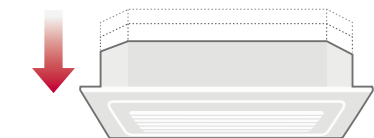

Capacity	Height
7.1 - 9.0kW	204mm
10.6kW	246mm
12.3 - 15.8kW	288mm

* Length width : 840 x 840mm

Convenient Panel Installation

The detachable corner design makes it easy to adjust the hanger during installation and to check for leakages in the drain connection pipe.

Detachable Corner Design

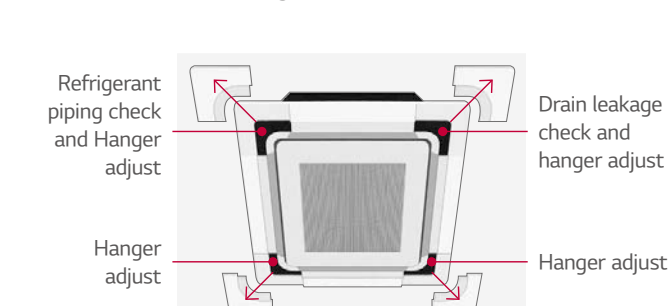

Drain leakage check

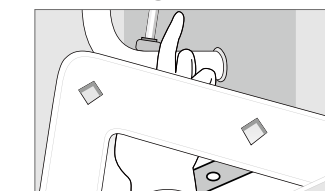

Hanger adjust

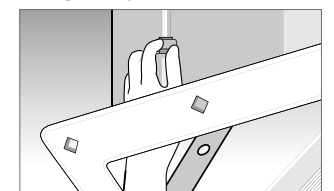

It is easy to install the panel to the body, using the button type panel design.

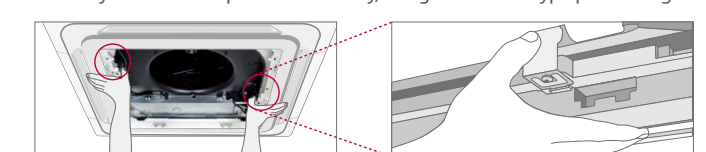

4 Way CASSETTE (570 X 570)

ARNU05GTRD4 / ARNU07GTRD4 / ARNU09GTRD4 / ARNU12GTRD4
ARNU15GTQD4 / ARNU18GTQD4 / ARNU21GTQD4



Model	Unit	ARNU05GTRD4	ARNU07GTRD4	ARNU09GTRD4	ARNU12GTRD4	ARNU15GTQD4	ARNU18GTQD4	ARNU21GTQD4	
Cooling Capacity	kW	1.6	2.2	2.8	3.6	4.5	5.6	6.0	
Heating Capacity	kW	1.8	2.5	3.2	4.0	5.0	6.3	6.8	
Power Input (H / M / L)	Nominal	W	13 / 12 / 11	13 / 12 / 11	14 / 13 / 12	17 / 15 / 13	24 / 21 / 18	25 / 22 / 19	28 / 23 / 20
	Body	mm	570 x 214 x 570	570 x 214 x 570	570 x 214 x 570	570 x 214 x 570	570 x 256 x 570	570 x 256 x 570	570 x 256 x 570
Dimensions (W x H x D)	Shipping	mm	667 x 285 x 646	667 x 285 x 646	667 x 285 x 646	667 x 285 x 646	667 x 327 x 646	667 x 327 x 646	667 x 327 x 646
	Type		Turbo Fan	Turbo Fan	Turbo Fan	Turbo Fan	Turbo Fan	Turbo Fan	Turbo Fan
Fan	Motor Output x Number	W	43 x 1	43 x 1	43 x 1	43 x 1	43 x 1	43 x 1	
	Air Flow Rate (H / M / L)	m ³ /min	7.5 / 7.0 / 6.6	7.5 / 7.0 / 6.6	8.0 / 7.5 / 7.1	8.7 / 8.0 / 7.0	11.0 / 10.0 / 9.3	11.2 / 11.0 / 10.0	12.0 / 11.1 / 9.4
	Motor type		BLDC	BLDC	BLDC	BLDC	BLDC	BLDC	BLDC
Air Filter		Pre Filter	Pre Filter	Pre Filter	Pre Filter	Pre Filter	Pre Filter	Pre Filter	
Pipe Connections	Liquid Side	mm (inch)	Ø6.35(1/4)	Ø6.35(1/4)	Ø6.35(1/4)	Ø6.35(1/4)	Ø6.35(1/4)	Ø9.52(3/8)	
	Gas Side	mm (inch)	Ø12.7(1/2)	Ø12.7(1/2)	Ø12.7(1/2)	Ø12.7(1/2)	Ø12.7(1/2)	Ø15.88(5/8)	
	Drain Pipe (Internal Dia.)	mm (inch)	Ø25 (1)	Ø25 (1)	Ø25 (1)	Ø25 (1)	Ø25 (1)	Ø25 (1)	
Weight	Body	kg	12.6	12.6	13.7	13.7	15.0	15.0	
Sound Pressure Levels (H / M / L)		dB(A)	29 / 27 / 26	29 / 27 / 26	30 / 29 / 27	32 / 30 / 27	36 / 34 / 32	37 / 35 / 34	40 / 38 / 34
Sound Power Levels (H / M / L)		dB(A)	45 / 43 / 42	45 / 43 / 42	46 / 43 / 42	48 / 46 / 43	50 / 48 / 46	51 / 50 / 46	53 / 51 / 46
Power Supply		Ø, V, Hz	1, 220-240, 50	1, 220-240, 50	1, 220-240, 50	1, 220-240, 50	1, 220-240, 50	1, 220-240, 50	
			1, 220, 60	1, 220, 60	1, 220, 60	1, 220, 60	1, 220, 60	1, 220, 60	
Communication Cable		mm ² x No.	1.0-1.5 x 2C	1.0-1.5 x 2C	1.0-1.5 x 2C	1.0-1.5 x 2C	1.0-1.5 x 2C	1.0-1.5 x 2C	
Decoration Panel (Accessory)	Model Name		PT-UQC PT-QCHW0	PT-UQC PT-QCHW0	PT-UQC PT-QCHW0	PT-UQC PT-QCHW0	PT-UQC PT-QCHW0	PT-UQC PT-QCHW0	
	Exterior Color		Morning Fog	Morning Fog	Morning Fog	Morning Fog	Morning Fog	Morning Fog	
	RAL Code		RAL 9001	RAL 9001	RAL 9001	RAL 9001	RAL 9001	RAL 9001	
	Net Dimensions (W x H x D)	mm	700 x 22 x 700 620 x 20 x 620	700 x 22 x 700 620 x 20 x 620	700 x 22 x 700 620 x 20 x 620	700 x 22 x 700 620 x 20 x 620	700 x 22 x 700 620 x 20 x 620	700 x 22 x 700 620 x 20 x 620	
	Net Weight	kg	3.0 / 3.0	3.0 / 3.0	3.0 / 3.0	3.0 / 3.0	3.0 / 3.0	3.0 / 3.0	

* Nominal : Performance tested under EN14511

* Rated : Max power input allowed for fan motor

Note : 1. Capacities are based on the following conditions

- Cooling : Indoor temp. 27°C (80.6°F) DB / 19°C (66.2°F) WB, Outdoor temp. 35°C (95°F) DB / 24°C (75.2°F) WB, Interconnecting piping length 7.5m, Level difference of zero

- Heating : Indoor temp. 20°C (68°F) DB / 15°C (59°F) WB, Outdoor temp. 7°C (44.6°F) DB / 6°C (42.8°F) WB, Interconnecting piping length 7.5m, Level difference of zero

2. Due to our policy of innovation some specifications may be changed without notification

3. I.D : 'Internal Diameter'

Accessories

Chassis	ARNU05GTRD4	ARNU07GTRD4	ARNU09GTRD4	ARNU12GTRD4	ARNU15GTQD4	ARNU18GTQD4	ARNU21GTQD4
Drain Pump				○			
Cassette Cover				PTDCQ			
Refrigerant Leakage Detector				PRLDNVSO			
EEV Kit				PRGK024A0 (-4.5kW)			
Independent Power Module				PRIP0			
Robot Cleaner				-			
Pre Filter (washable / anti-fungus)				○			
Ion Generator				-			
CO ₂ Sensor				-			
Ventilation Kit				PTVK430			
IR Receiver				-			
Zone Controller				-			
Dry Contact (with additional accessory)				PDRYCB000 (1 point contact) PDRYCB300 (8 points for thermostat compatible) PDRYCB400 (2 points input) PDRYCB501 (Modbus)			
External Input (1 point)				○			
Wi-Fi				PWFMD200			

※ ○ : Applied, - : Not applied

Option : Refer to model name in table

ARNU05GTRC4 / ARNU07GTRC4 / ARNU09GTRC4 / ARNU12GTRC4
ARNU15GTQC4 / ARNU18GTQC4 / ARNU21GTQC4



Model	Unit	ARNU05GTRC4	ARNU07GTRC4	ARNU09GTRC4	ARNU12GTRC4	ARNU15GTQC4	ARNU18GTQC4	ARNU21GTQC4	
Cooling Capacity	kW	1.6	2.2	2.8	3.6	4.5	5.6	6.0	
Heating Capacity	kW	1.8	2.5	3.2	4.0	5.0	6.3	6.8	
Power Input (H / M / L)	Nominal	W	13 / 12 / 11	13 / 12 / 11	14 / 13 / 12	17 / 15 / 13	24 / 21 / 18	25 / 22 / 19	28 / 23 / 20
	Body	mm	570 x 214 x 570	570 x 214 x 570	570 x 214 x 570	570 x 214 x 570	570 x 256 x 570	570 x 256 x 570	570 x 256 x 570
Dimensions (W x H x D)	Shipping	mm	667 x 285 x 646	667 x 285 x 646	667 x 285 x 646	667 x 285 x 646	667 x 327 x 646	667 x 327 x 646	
	Type		Turbo Fan	Turbo Fan	Turbo Fan	Turbo Fan	Turbo Fan	Turbo Fan	
Fan	Motor Output x Number	W	43 x 1	43 x 1	43 x 1	43 x 1	43 x 1	43 x 1	
	Air Flow Rate (H / M / L)	m ³ /min	7.5 / 7.0 / 6.6	7.5 / 7.0 / 6.6	8.0 / 7.5 / 7.1	8.7 / 8.0 / 7.0	11.0 / 10.0 / 9.3	11.2 / 11.0 / 10.0	12.0 / 11.1 / 9.4
	Motor type		BLDC	BLDC	BLDC	BLDC	BLDC	BLDC	
Air Filter		Pre Filter	Pre Filter	Pre Filter	Pre Filter	Pre Filter	Pre Filter	Pre Filter	
Pipe Connections	Liquid Side	mm (inch)	Ø6.35(1/4)	Ø6.35(1/4)	Ø6.35(1/4)	Ø6.35(1/4)	Ø6.35(1/4)	Ø9.52(3/8)	
	Gas Side	mm (inch)	Ø12.7(1/2)	Ø12.7(1/2)	Ø12.7(1/2)	Ø12.7(1/2)	Ø12.7(1/2)	Ø15.88(5/8)	
	Drain Pipe (Internal Dia.)	mm (inch)	Ø25 (1)	Ø25 (1)	Ø25 (1)	Ø25 (1)	Ø25 (1)	Ø25 (1)	
Weight	Body	kg	12.6	12.6	13.7	13.7	15.0	15.0	
Sound Pressure Levels (H / M / L)		dB(A)	29 / 27 / 26	29 / 27 / 26	30 / 29 / 27	32 / 30 / 27	36 / 34 / 32	37 / 35 / 34	40 / 38 / 34
Sound Power Levels (H / M / L)		dB(A)	45 / 43 / 42	45 / 43 / 42	46 / 43 / 42	48 / 46 / 43	50 / 48 / 46	51 / 50 / 46	53 / 51 / 46
Power Supply		Ø, V, Hz	1, 220-240, 50	1, 220-240, 50	1, 220-240, 50	1, 220-240, 50	1, 220-240, 50	1, 220-240, 50	
			1, 220, 60	1, 220, 60	1, 220, 60	1, 220, 60	1, 220, 60	1, 220, 60	
Communication Cable		mm ² x No.	1.0-1.5 x 2C	1.0-1.5 x 2C	1.0-1.5 x 2C	1.0-1.5 x 2C	1.0-1.5 x 2C	1.0-1.5 x 2C	
Decoration Panel (Accessory)	Model Name		PT-UQC PT-QCHW0	PT-UQC PT-QCHW0	PT-UQC PT-QCHW0	PT-UQC PT-QCHW0	PT-UQC PT-QCHW0	PT-UQC PT-QCHW0	
	Exterior Color		Morning Fog	Morning Fog	Morning Fog	Morning Fog	Morning Fog	Morning Fog	
	RAL Code		RAL 9001	RAL 9001	RAL 9001	RAL 9001	RAL 9001	RAL 9001	
	Net Dimensions (W x H x D)	mm	700 x 22 x 700 620 x 20 x 620	700 x 22 x 700 620 x 20 x 620	700 x 22 x 700 620 x 20 x 620	700 x 22 x 700 620 x 20 x 620	700 x 22 x 700 620 x 20 x 620	700 x 22 x 700 620 x 20 x 620	
	Net Weight	kg	3.0 / 3.0	3.0 / 3.0	3.0 / 3.0	3.0 / 3.0	3.0 / 3.0	3.0 / 3.0	

* Nominal : Performance tested under EN14511

* Rated : Max power input allowed for fan motor

Note : 1. Capacities are based on the following conditions

- Cooling : Indoor temp. 27°C (80.6°F) DB / 19°C (66.2°F) WB, Outdoor temp. 35°C (95°F) DB / 24°C (75.2°F) WB, Interconnecting piping length 7.5m, Level difference of zero

- Heating : Indoor temp. 20°C (68°F) DB / 15°C (59°F) WB, Outdoor temp. 7°C (44.6°F) DB / 6°C (42.8°F) WB, Interconnecting piping length 7.5m, Level difference of zero

2. Due to our policy of innovation some specifications may be changed without notification

3. I.D : 'Internal Diameter'

Accessories

Chassis	ARNU05GTRC4	ARNU07GTRC4	ARNU09GTRC4	ARNU12GTRC4	ARNU15GTQC4	ARNU18GTQC4	ARNU21GTQC4
Drain Pump				○			
Cassette Cover				PTDCQ			
Refrigerant Leakage Detector				PRLDNVSO			
EEV Kit				PRGK024A0 (-4.5kW)			
Independent Power Module				PRIP0			
Robot Cleaner				-			
Pre Filter (washable / anti-fungus)				○			
Ion Generator				-			
CO ₂ Sensor				-			
Ventilation Kit				PTVK430			
IR Receiver				-			
Zone Controller				-			
Dry Contact (with additional accessory)				PDRYCB000 (1 point contact) PDRYCB300 (8 points for thermostat compatible) PDRYCB400 (2 points input) PDRYCB500 (Modbus)			
External Input (1 point)				○			
Wi-Fi				-			

※ ○ : Applied, - : Not applied

Option : Refer to model name in table

4 Way CASSETTE (840 X 840)

ARNU24GTPC4 / ARNU28GTPC4 / ARNU30GTPC4 / ARNU36GTNC4



Model	Unit	ARNU24GTPC4	ARNU28GTPC4	ARNU30GTPC4	ARNU36GTNC4	
Cooling Capacity	kW	7.1	8.2	9.0	10.6	
Heating Capacity	kW	8.0	9.2	10.0	11.9	
Power Input (H / M / L)	Nominal	W	31 / 26 / 23	40 / 31 / 25	40 / 34 / 27	70 / 53 / 43
	Body	mm	840 x 204 x 840	840 x 204 x 840	840 x 204 x 840	840 x 246 x 840
Dimensions (W x H x D)	Shipping	mm	922 x 276 x 917	922 x 276 x 917	922 x 276 x 917	922 x 318 x 917
	Type		Turbo Fan	Turbo Fan	Turbo Fan	Turbo Fan
Fan	Motor Output x Number	W	30 x 1	30 x 1	30 x 1	135 x 1
	Air Flow Rate (H / M / L)	m ³ /min	17.0 / 15.0 / 13.0	19.0 / 16.0 / 14.0	24.3 / 22.8 / 19.5	25.0 / 21.0 / 19.0
	Motor type		BLDC	BLDC	BLDC	BLDC
Air Filter			Pre Filter	Pre Filter	Pre Filter	Pre Filter
Pipe Connections	Liquid Side	mm (inch)	Ø9.52(3/8)	Ø9.52(3/8)	Ø9.52(3/8)	Ø9.52(3/8)
	Gas Side	mm (inch)	Ø15.88(5/8)	Ø15.88(5/8)	Ø15.88(5/8)	Ø15.88(5/8)
	Drain Pipe (Internal Dia.)	mm (inch)	Ø25 (1)	Ø25 (1)	Ø25 (1)	Ø25 (1)
Weight	Body	kg	20.8	20.8	20.8	23.5
Sound Pressure Levels (H / M / L)		dB(A)	36 / 34 / 31	39 / 35 / 33	40 / 36 / 33	43 / 40 / 37
Sound Power Levels (H / M / L)		dB(A)	46 / 44 / 43	52 / 46 / 44	58 / 57 / 54	56 / 53 / 51
Power Supply		Ø, V, Hz	1, 220-240, 50	1, 220-240, 50	1, 220-240, 50	1, 220-240, 50
			1, 220, 60	1, 220, 60	1, 220, 60	1, 220, 60
Communication Cable		mm ² x No.	1.0-1.5 x 2C	1.0-1.5 x 2C	1.0-1.5 x 2C	1.0-1.5 x 2C
Decoration Panel (Accessory)	Model Name		PT-UMC1 PT-MCHW0	PT-UMC1 PT-MCHW0	PT-UMC1 PT-MCHW0	PT-UMC1 PT-MCHW0
	Exterior Color		Morning Fog	Morning Fog	Morning Fog	Morning Fog
	RAL Code		RAL 9001	RAL 9001	RAL 9001	RAL 9001
	Net Dimensions (W x H x D)	mm	950 x 25 x 950 950 x 35 x 950	950 x 25 x 950 950 x 35 x 950	950 x 25 x 950 950 x 35 x 950	950 x 25 x 950 950 x 35 x 950
	Net Weight	kg	5.0 / 6.3	5.0 / 6.3	5.0 / 6.3	5.0 / 6.3

* Nominal : Performance tested under EN14511

* Rated : Max power input allowed for fan motor

Note : 1. Capacities are based on the following conditions

- Cooling : Indoor temp. 27°C (80.6°F) DB / 19°C (66.2°F) WB, Outdoor temp. 35°C (95°F) DB / 24°C (75.2°F) WB, Interconnecting piping length 7.5m, Level difference of zero

- Heating : Indoor temp. 20°C (68°F) DB / 15°C (59°F) WB, Outdoor temp. 7°C (44.6°F) DB / 6°C (42.8°F) WB, Interconnecting piping length 7.5m, Level difference of zero

2. Due to our policy of innovation some specifications may be changed without notification

3. ID : 'Internal Diameter'

Accessories

Chassis	ARNU24GTPC4	ARNU28GTPC4	ARNU30GTPC4	ARNU36GTNC4
Drain Pump			○	
Cassette Cover			PTDCM	
Refrigerant Leakage Detector			PRLDNVSO	
EEV Kit			-	
Independent Power Module			PRIP0	
Robot Cleaner			-	
Pre Filter (washable / anti-fungus)			○	
Ion Generator			-	
CO ₂ Sensor			-	
Ventilation Kit			PTVK430	
IR Receiver			-	
Zone Controller			-	
Dry Contact (with additional accessory)			PDRYCB000 (1 point contact) PDRYCB300 (8 points for thermostat compatible) PDRYCB400 (2 points input) PDRYCB502 (Modbus)	
External Input (1 point)			○	
Wi-Fi			PWFMDD200	

※ ○ : Applied, - : Not applied

Option : Refer to model name in table

ARNU42GTM / C4ARNU48GTM4 / ARNU54GTM4



Model	Unit	ARNU42GTM4	ARNU48GTM4	ARNU54GTM4	
Cooling Capacity	kW	12.3	14.1	15.8	
Heating Capacity	kW	13.8	15.9	18.0	
Power Input (H / M / L)	Nominal	W	104 / 75 / 53	120 / 80 / 62	135 / 93 / 70
	Body	mm	840 x 288 x 840	840 x 288 x 840	840 x 288 x 840
Dimensions (W x H x D)	Shipping	mm	922 x 360 x 917	922 x 360 x 917	922 x 360 x 917
	Type		Turbo Fan	Turbo Fan	Turbo Fan
Fan	Motor Output x Number	W	135 x 1	135 x 1	135 x 1
	Air Flow Rate (H / M / L)	m ³ /min	30.0 / 27.0 / 24.0	31.0 / 29.0 / 27.0	34.0 / 32.0 / 27.0
	Motor type		BLDC	BLDC	BLDC
Air Filter			Pre Filter	Pre Filter	Pre Filter
Pipe Connections	Liquid Side	mm (inch)	Ø9.52(3/8)	Ø9.52(3/8)	Ø9.52(3/8)
	Gas Side	mm (inch)	Ø15.88(5/8)	Ø15.88(5/8)	Ø15.88(5/8)
	Drain Pipe (Internal Dia.)	mm (inch)	Ø25 (1)	Ø25 (1)	Ø25 (1)
Weight	Body	kg	25.6	25.6	26.5
Sound Pressure Levels (H / M / L)		dB(A)	44 / 41 / 38	46 / 43 / 41	50 / 48 / 44
Sound Power Levels (H / M / L)		dB(A)	58 / 55 / 50	60 / 56 / 55	60 / 58 / 55
Power Supply		Ø, V, Hz	1, 220-240, 50	1, 220-240, 50	1, 220-240, 50
			1, 220, 60	1, 220, 60	1, 220, 60
Communication Cable		mm ² x No.	1.0-1.5 x 2C	1.0-1.5 x 2C	1.0-1.5 x 2C
Decoration Panel (Accessory)	Model Name		PT-UMC1 PT-MCHW0	PT-UMC1 PT-MCHW0	PT-UMC1 PT-MCHW0
	Exterior Color		Morning Fog	Morning Fog	Morning Fog
	RAL Code		RAL 9001	RAL 9001	RAL 9001
	Net Dimensions (W x H x D)	mm	950 x 25 x 950 950 x 35 x 950	950 x 25 x 950 950 x 35 x 950	950 x 25 x 950 950 x 35 x 950
	Net Weight	kg	5.0 / 6.3	5.0 / 6.3	5.0 / 6.3

* Nominal : Performance tested under EN14511

* Rated : Max power input allowed for fan motor

Note : 1. Capacities are based on the following conditions

- Cooling : Indoor temp. 27°C (80.6°F) DB / 19°C (66.2°F) WB, Outdoor temp. 35°C (95°F) DB / 24°C (75.2°F) WB, Interconnecting piping length 7.5m, Level difference of zero

- Heating : Indoor temp. 20°C (68°F) DB / 15°C (59°F) WB, Outdoor temp. 7°C (44.6°F) DB / 6°C (42.8°F) WB, Interconnecting piping length 7.5m, Level difference of zero

2. Due to our policy of innovation some specifications may be changed without notification

3. ID : 'Internal Diameter'

Accessories

Chassis	ARNU42GTM4	ARNU48GTM4	ARNU54GTM4
Drain Pump			○
Cassette Cover			PTDCM
Refrigerant Leakage Detector			PRLDNVSO
EEV Kit			-
Independent Power Module			PRIP0
Robot Cleaner			-
Pre Filter (washable / anti-fungus)			○
Ion Generator			-
CO ₂ Sensor			-
Ventilation Kit			PTVK430
IR Receiver			-
Zone Controller			-
Dry Contact (with additional accessory)			PDRYCB000 (1 point contact) PDRYCB300 (8 points for thermostat compatible) PDRYCB400 (2 points input) PDRYCB502 (Modbus)
External Input (1 point)			○
Wi-Fi			PWFMDD200

※ ○ : Applied, - : Not applied

Option : Refer to model name in table

4 Way CASSETTE HIGH SENSIBLE (840 X 840)

ARNU07GTNA4 / ARNU09GTNA4 / ARNU12GTNA4
ARNU15GTNA4 / ARNU18GTNA4



Model	Unit	ARNU07GTNA4	ARNU09GTNA4	ARNU12GTNA4	ARNU15GTNA4	ARNU18GTNA4	
Cooling Capacity	kW	2.2	2.8	3.6	4.5	5.6	
Heating Capacity	kW	2.5	3.2	4	5	6.3	
Power Input (H / M / L)	Nominal	18 / 15 / 12	19 / 15 / 12	22 / 17 / 14	25 / 17 / 14	27 / 18 / 14	
	Body	mm	840 x 246 x 840	840 x 246 x 840	840 x 246 x 840	840 x 246 x 840	
Dimensions (W x H x D)	Shipping	mm	922 x 318 x 917	922 x 318 x 917	922 x 318 x 917	922 x 318 x 917	
	Type		Turbo Fan	Turbo Fan	Turbo Fan	Turbo Fan	
Fan	Motor Output x Number	W	135 x 1	135 x 1	135 x 1	135 x 1	
	Air Flow Rate (H / M / L)	m ³ /min	13.0 / 12.0 / 11.0	13.5 / 12.0 / 11.0	14.0 / 13.0 / 12.0	15.0 / 13.0 / 12.0	
	Motor type		BLDC	BLDC	BLDC	BLDC	
Air Filter		Pre Filter	Pre Filter	Pre Filter	Pre Filter	Pre Filter	
Pipe Connections	Liquid Side	mm (inch)	Ø9.52(3/8)	Ø9.52(3/8)	Ø9.52(3/8)	Ø9.52(3/8)	
	Gas Side	mm (inch)	Ø15.88(5/8)	Ø15.88(5/8)	Ø15.88(5/8)	Ø15.88(5/8)	
	Drain Pipe (Internal Dia.)	mm (inch)	Ø25 (1)	Ø25 (1)	Ø25 (1)	Ø25 (1)	
Weight	Body	kg	23.5	23.5	23.5	23.5	
Sound Pressure Levels (H / M / L)	dB(A)	35 / 33 / 30	35 / 33 / 30	37 / 35 / 33	39 / 35 / 33	40 / 35 / 33	
Sound Power Levels (H / M / L)	dB(A)	42 / 38 / 36	42 / 38 / 36	43 / 40 / 38	44 / 40 / 38	45 / 41 / 38	
Power Supply	Ø, V, Hz	1, 220-240, 50	1, 220-240, 50	1, 220-240, 50	1, 220-240, 50	1, 220-240, 50	
		1, 220, 60	1, 220, 60	1, 220, 60	1, 220, 60	1, 220, 60	
Communication Cable	mm ² x No.	1.0-1.5 x 2C	1.0-1.5 x 2C	1.0-1.5 x 2C	1.0-1.5 x 2C	1.0-1.5 x 2C	
Decoration Panel (Accessory)	Model Name	PT-UMC1 PT-MCHW0	PT-UMC1 PT-MCHW0	PT-UMC1 PT-MCHW0	PT-UMC1 PT-MCHW0	PT-UMC1 PT-MCHW0	
	Exterior Color	Morning Fog	Morning Fog	Morning Fog	Morning Fog	Morning Fog	
	RAL Code	RAL 9001	RAL 9001	RAL 9001	RAL 9001	RAL 9001	
	Net Dimensions (W x H x D)	mm	950 x 25 x 950 950 x 35 x 950	950 x 25 x 950 950 x 35 x 950	950 x 25 x 950 950 x 35 x 950	950 x 25 x 950 950 x 35 x 950	950 x 25 x 950 950 x 35 x 950
	Net Weight	kg	5.0 / 6.3	5.0 / 6.3	5.0 / 6.3	5.0 / 6.3	

* Nominal : Performance tested under EN14511

* Rated : Max power input allowed for fan motor

Note : 1. Capacities are based on the following conditions

- Cooling : Indoor temp. 27°C (80.6°F) DB / 19°C (66.2°F) WB, Outdoor temp. 35°C (95°F) DB / 24°C (75.2°F) WB, Interconnecting piping length 7.5m, Level difference of zero

- Heating : Indoor temp. 20°C (68°F) DB / 15°C (59°F) WB, Outdoor temp. 7°C (44.6°F) DB / 6°C (42.8°F) WB, Interconnecting piping length 7.5m, Level difference of zero

2. Due to our policy of innovation some specifications may be changed without notification

3. I.D : 'Internal Diameter'

Accessories

Chassis	ARNU07GTNA4	ARNU09GTNA4	ARNU12GTNA4	ARNU15GTNA4	ARNU18GTNA4
Drain Pump			○		
Cassette Cover			PTDCM		
Refrigerant Leakage Detector			PRLDNVSO		
EEV Kit			-		
Independent Power Module			PRIPO		
Robot Cleaner			-		
Pre Filter (washable / anti-fungus)			○		
Ion Generator			-		
CO ₂ Sensor			-		
Ventilation Kit			PTVK430		
IR Receiver			-		
Zone Controller			-		
Dry Contact (with additional accessory)			PDRYCB000 (1 point contact) PDRYCB300 (8 points for thermostat compatible) PDRYCB400 (2 points input) PDRYCB500 (Modbus)		
External Input (1 point)			○		
Wi-Fi			PWFMD200		

※ ○ : Applied, - : Not applied
Option : Refer to model name in table

ARNU24GTMA4 / ARNU28GTMA4
ARNU36GTMA4 / ARNU42GTMA4



Model	Unit	ARNU24GTMA4	ARNU28GTMA4	ARNU36GTMA4	ARNU42GTMA4	
Cooling Capacity	kW	7.1	8.2	10.6	12.3	
Heating Capacity	kW	8	9.2	11.9	13.8	
Power Input (H / M / L)	Nominal	W	47 / 39 / 31	52 / 43 / 31	64 / 47 / 34	
	Body	mm	840 x 288 x 840	840 x 288 x 840	840 x 288 x 840	
Dimensions (W x H x D)	Shipping	mm	922 x 360 x 917	922 x 360 x 917	922 x 360 x 917	
	Type		Turbo Fan	Turbo Fan	Turbo Fan	
Fan	Motor Output x Number	W	135 x 1	135 x 1	135 x 1	
	Air Flow Rate (H / M / L)	m ³ /min	22.0 / 20.0 / 18.0	23.0 / 21.0 / 18.0	26.0 / 23.0 / 20.0	
	Motor type		BLDC	BLDC	BLDC	
Air Filter		Pre Filter	Pre Filter	Pre Filter	Pre Filter	
Pipe Connections	Liquid Side	mm (inch)	Ø9.52(3/8)	Ø9.52(3/8)	Ø9.52(3/8)	
	Gas Side	mm (inch)	Ø15.88(5/8)	Ø15.88(5/8)	Ø15.88(5/8)	
	Drain Pipe (Internal Dia.)	mm (inch)	Ø25 (1)	Ø25 (1)	Ø25 (1)	
Weight	Body	kg	25.6	25.6	25.6	
Sound Pressure Levels (H / M / L)	dB(A)	42 / 40 / 38	43 / 41 / 38	46 / 42 / 39	49 / 45 / 42	
Sound Power Levels (H / M / L)	dB(A)	48 / 45 / 43	49 / 47 / 43	52 / 48 / 44	55 / 51 / 48	
Power Supply	Ø, V, Hz	1, 220-240, 50	1, 220-240, 50	1, 220-240, 50	1, 220-240, 50	
		1, 220, 60	1, 220, 60	1, 220, 60	1, 220, 60	
Communication Cable	mm ² x No.	1.0-1.5 x 2C	1.0-1.5 x 2C	1.0-1.5 x 2C	1.0-1.5 x 2C	
Decoration Panel (Accessory)	Model Name	PT-UMC1 PT-MCHW0	PT-UMC1 PT-MCHW0	PT-UMC1 PT-MCHW0	PT-UMC1 PT-MCHW0	
	Exterior Color	Morning Fog	Morning Fog	Morning Fog	Morning Fog	
	RAL Code	RAL 9001	RAL 9001	RAL 9001	RAL 9001	
	Net Dimensions (W x H x D)	mm	950 x 25 x 950 950 x 35 x 950	950 x 25 x 950 950 x 35 x 950	950 x 25 x 950 950 x 35 x 950	950 x 25 x 950 950 x 35 x 950
	Net Weight	kg	5.0 / 6.3	5.0 / 6.3	5.0 / 6.3	

* Nominal : Performance tested under EN14511

* Rated : Max power input allowed for fan motor

Note : 1. Capacities are based on the following conditions

- Cooling : Indoor temp. 27°C (80.6°F) DB / 19°C (66.2°F) WB, Outdoor temp. 35°C (95°F) DB / 24°C (75.2°F) WB, Interconnecting piping length 7.5m, Level difference of zero

- Heating : Indoor temp. 20°C (68°F) DB / 15°C (59°F) WB, Outdoor temp. 7°C (44.6°F) DB / 6°C (42.8°F) WB, Interconnecting piping length 7.5m, Level difference of zero

2. Due to our policy of innovation some specifications may be changed without notification

3. I.D : 'Internal Diameter'

Accessories

Chassis	ARNU24GTMA4	ARNU28GTMA4	ARNU36GTMA4	ARNU42GTMA4
Drain Pump			○	
Cassette Cover			PTDCM	
Refrigerant Leakage Detector			PRLDNVSO	
EEV Kit			-	
Independent Power Module			PRIPO	
Robot Cleaner			-	
Pre Filter (washable / anti-fungus)			○	
Ion Generator			-	
CO ₂ Sensor			-	
Ventilation Kit			PTVK430	
IR Receiver			-	
Zone Controller			-	
Dry Contact (with additional accessory)			PDRYCB000 (1 point contact) PDRYCB300 (8 points for thermostat compatible) PDRYCB400 (2 points input) PDRYCB500 (Modbus)	
External Input (1 point)			○	
Wi-Fi			PWFMD200	

※ ○ : Applied, - : Not applied
Option : Refer to model name in table

2 Way CASSETTE

ARNU09GTSC4 / ARNU12GTSC4
ARNU18GTSC4 / ARNU24GTSC4



Model	Unit	ARNU09GTSC4	ARNU12GTSC4	ARNU18GTSC4	ARNU24GTSC4	
Cooling Capacity	kW	2.8	3.6	5.6	7.1	
Heating Capacity	kW	3.2	4	6.3	8	
Power Input (H / M / L)	Nominal	16 / 14 / 11	18 / 14 / 11	19 / 16 / 14	31 / 22 / 14	
	W					
Dimensions (W x H x D)	Body	830 x 225 x 600	830 x 225 x 600	830 x 225 x 600	830 x 225 x 600	
	Shipping	1,033 x 270 x 665	1,033 x 270 x 665	1,033 x 270 x 665	1,033 x 270 x 665	
Fan	Type	Turbo Fan	Turbo Fan	Turbo Fan	Turbo Fan	
	Motor Output x Number	W x No.	37 x 1	37 x 1	37 x 1	
	Air Flow Rate (H / M / L)	m ³ /min	10.8 / 9.8 / 9.1	11.1 / 10.3 / 9.1	11.8 / 10.8 / 9.8	14.5 / 12.4 / 10.3
	Motor type		BLDC	BLDC	BLDC	
Air Filter		Pre Filter	Pre Filter	Pre Filter	Pre Filter	
Pipe Connections	Liquid Side	mm (inch)	Ø6.35 (1/4)	Ø6.35 (1/4)	Ø6.35 (1/4)	Ø9.52(3/8)
	Gas Side	mm (inch)	Ø12.7 (1/2)	Ø12.7 (1/2)	Ø12.7 (1/2)	Ø15.88(5/8)
	Drain Pipe (Internal Dia.)	mm (inch)	Ø25 (1)	Ø25 (1)	Ø25 (1)	Ø25 (1)
Weight	Body	kg	18.1	18.1	18.1	18.1
Sound Pressure Levels (H / M / L)		dB (A)	33 / 31 / 29	34 / 32 / 29	35 / 33 / 31	40 / 37 / 33
Sound Power Levels (H / M / L)		dB (A)	42 / 40 / 38	43 / 41 / 39	44 / 42 / 40	48 / 45 / 40
Power Supply		∅, V, Hz	1, 220-240, 50	1, 220-240, 50	1, 220-240, 50	1, 220-240, 50
			1, 220, 60	1, 220, 60	1, 220, 60	1, 220, 60
Communication Cable		mm ² x No.	1.0-1.5 x 2C	1.0-1.5 x 2C	1.0-1.5 x 2C	1.0-1.5 x 2C
Decoration Panel (Accessory)	Model Name		PT-USC	PT-USC	PT-USC	PT-USC
	Exterior Color		Morning Fog	Morning Fog	Morning Fog	Morning Fog
	RAL Code		RAL 9001	RAL 9001	RAL 9001	RAL 9001
	Net Dimensions (W x H x D)	mm	1,100 x 28 x 690	1,100 x 28 x 690	1,100 x 28 x 690	1,100 x 28 x 690
	Net Weight	kg	4.7	4.7	4.7	4.7

* Nominal : Performance tested under EN14511
 * Rated : Max power input allowed for fan motor
 Note : 1. Capacities are based on the following conditions
 - Cooling : Indoor temp. 27°C (80.6°F) DB / 19°C (66.2°F) WB, Outdoor temp. 35°C (95°F) DB / 24°C (75.2°F) WB, Interconnecting piping length 7.5m, Level difference of zero
 - Heating : Indoor temp. 20°C (68°F) DB / 15°C (59°F) WB, Outdoor temp. 7°C (44.6°F) DB / 6°C (42.8°F) WB, Interconnecting piping length 7.5m, Level difference of zero
 2. Due to our policy of innovation some specifications may be changed without notification
 3. I.D : 'Internal Diameter'

Accessories

Chassis	ARNU09GTSC4	ARNU12GTSC4	ARNU18GTSC4	ARNU24GTSC4
Drain Pump			○	
Cassette Cover			-	
Refrigerant Leakage Detector		PRLDNVSO		
EEV Kit		PRGK024A0 (-5.6kW)		
Independent Power Module		PRIPO		
Robot Cleaner		-		
Pre Filter (washable / anti-fungus)		○		
Ion Generator		-		
CO ₂ Sensor		-		
Ventilation Kit		-		
IR Receiver		-		
Zone Controller		-		
Dry Contact (with additional accessory)		PDRYCB000 (1 point contact) PDRYCB300 (8 points for thermostat compatible) PDRYCB400 (2 points input) PDRYCB500 (Modbus)		
External Input (1 point)		○		
Wi-Fi		PWFMD200		

※ ○ : Applied, - : Not applied
 Option : Refer to model name in table

1 Way CASSETTE

ARNU07GTUD4 / ARNU09GTUD4 / ARNU12GTUD4
ARNU18GTTD4 / ARNU24GTTD4



Model	Unit	ARNU07GTUC4	ARNU09GTUC4	ARNU12GTUC4	ARNU18GTTC4	ARNU24GTTC4	
Cooling Capacity	kW	2.2	2.8	3.6	5.6	7.1	
Heating Capacity	kW	2.5	3.2	4.0	6.3	7.1	
Power Input (H / M / L)	Nominal	20 / 18 / 16	22 / 20 / 18	24 / 22 / 20	38 / 28 / 24	51 / 33 / 26	
	W						
Dimensions (W x H x D)	Body	860 x 132 x 450	860 x 132 x 450	860 x 132 x 450	1,180 x 132 x 450	1,180 x 132 x 450	
	Shipping	1,129 x 259 x 538	1,129 x 259 x 538	1,129 x 259 x 538	1,499 x 259 x 538	1,499 x 259 x 538	
Fan	Type	Cross Flow Fan	Cross Flow Fan	Cross Flow Fan	Cross Flow Fan	Cross Flow Fan	
	Motor Output x Number	W x No.	30 x 1	30 x 1	30 x 1	30 x 1	
	Air Flow Rate (H / M / L)	m ³ /min	8.2 / 7.3 / 6.4	9.2 / 8.6 / 8.2	10.0 / 9.2 / 8.2	13.3 / 12.1 / 10.9	14.6 / 13.3 / 11.5
	Motor type		BLDC	BLDC	BLDC	BLDC	
Air Filter		Pre Filter	Pre Filter	Pre Filter	Pre Filter	Pre Filter	
Pipe Connections	Liquid Side	mm (inch)	Ø6.35(1/4)	Ø6.35(1/4)	Ø6.35(1/4)	Ø9.52(3/8)	
	Gas Side	mm (inch)	Ø12.7(1/2)	Ø12.7(1/2)	Ø12.7(1/2)	Ø15.88(5/8)	
	Drain Pipe (Internal Dia.)	mm (inch)	Ø25(1)	Ø25(1)	Ø25(1)	Ø25(1)	
Weight	Body	kg	13.6	13.6	13.6	15.6	
Sound Pressure Levels (H / M / L)		dB (A)	32 / 29 / 25	35 / 34 / 32	38 / 35 / 32	40 / 37 / 35	
Sound Power Levels (H / M / L)		dB (A)	47 / 44 / 41	50 / 48 / 47	52 / 50 / 47	56 / 51 / 48	
Power Supply		∅, V, Hz	1, 220-240, 50	1, 220-240, 50	1, 220-240, 50	1, 220-240, 50	
			1, 220, 60	1, 220, 60	1, 220, 60	1, 220, 60	
Communication Cable		mm ² x No.	1.0-1.5 x 2C	1.0-1.5 x 2C	1.0-1.5 x 2C	1.0-1.5 x 2C	
Decoration Panel (Accessory)	Model Name		PT-UUC(Grill) PT-UUD(Panel)	PT-UUC(Grill) PT-UUD(Panel)	PT-UTC(Grill) PT-UTD(Panel)	PT-UTC(Grill) PT-UTD(Panel)	
	Exterior Color		Noble White	Noble White	Noble White	Noble White	
	RAL Code		RAL 9003	RAL 9003	RAL 9003	RAL 9003	
	Net Dimensions (W x H x D)	mm	1,100 x 34 x 500 1,100 x 34 x 500	1,100 x 34 x 500 1,100 x 34 x 500	1,100 x 34 x 500 1,100 x 34 x 500	1,420 x 34 x 500 1,420 x 34 x 500	
	Net Weight	kg	4.6 / 5.3	4.6 / 5.3	4.6 / 5.3	5.5 / 6.5	

* Nominal : Performance tested under EN14511
 * Rated : Max power input allowed for fan motor
 Note : 1. Capacities are based on the following conditions
 - Cooling : Indoor temp. 27°C (80.6°F) DB / 19°C (66.2°F) WB, Outdoor temp. 35°C (95°F) DB / 24°C (75.2°F) WB, Interconnecting piping length 7.5m, Level difference of zero
 - Heating : Indoor temp. 20°C (68°F) DB / 15°C (59°F) WB, Outdoor temp. 7°C (44.6°F) DB / 6°C (42.8°F) WB, Interconnecting piping length 7.5m, Level difference of zero
 2. Due to our policy of innovation some specifications may be changed without notification
 3. I.D : 'Internal Diameter'

Accessories

Chassis	ARNU07GTUC4	ARNU09GTUC4	ARNU12GTUC4	ARNU18GTTC4	ARNU24GTTC4
Drain Pump			○		○
Cassette Cover			-		-
Refrigerant Leakage Detector		PRLDNVSO			PRLDNVSO
EEV Kit		PRGK024A0			-
Independent Power Module		PRIPO			PRIPO
Robot Cleaner		-			-
Pre Filter (washable / anti-fungus)		○			○
Ion Generator		-			-
CO ₂ Sensor		-			-
Ventilation Kit		-			-
IR Receiver		-			-
Zone Controller		-			-
Dry Contact (with additional accessory)		PDRYCB000 (1 point contact) PDRYCB300 (8 points for thermostat compatible) PDRYCB400 (2 points input) PDRYCB500 (Modbus)			PDRYCB000 (1 point contact) PDRYCB300 (8 points for thermostat compatible) PDRYCB400 (2 points input) PDRYCB500 (Modbus) PDRYCB502 (Modbus)
External Input (1 point)		○			○
Wi-Fi		-			-

※ ○ : Applied, - : Not applied
 Option : Refer to model name in table

1 Way CASSETTE

ARNU07GTUD4 / ARNU09GTUD4 / ARNU12GTUD4



Model	Unit	ARNU07GTUD4	ARNU09GTUD4	ARNU12GTUD4	
Cooling Capacity	kW	2.2	2.8	3.6	
Heating Capacity	kW	2.5	3.2	4.0	
Power Input (H / M / L)	Nominal	20 / 18 / 16	22 / 20 / 18	24 / 22 / 20	
	W				
Dimensions (W x H x D)	Body	860 x 132 x 450	860 x 132 x 450	860 x 132 x 450	
	Shipping	1,129 x 259 x 538	1,129 x 259 x 538	1,129 x 259 x 538	
Fan	Type	Cross Flow Fan	Cross Flow Fan	Cross Flow Fan	
	Motor Output x Number	W x No.	30 x 1	30 x 1	
	Air Flow Rate (H / M / L)	m ³ /min	8.2 / 7.3 / 6.4	9.2 / 8.6 / 8.2	10.0 / 9.2 / 8.2
	Motor type		BLDC	BLDC	
Air Filter		Pre Filter	Pre Filter	Pre Filter	
Pipe Connections	Liquid Side	mm (inch)	Ø6.35(1/4)	Ø6.35(1/4)	
	Gas Side	mm (inch)	Ø12.7(1/2)	Ø12.7(1/2)	
	Drain Pipe (Internal Dia.)	mm (inch)	Ø25(1)	Ø25(1)	
Weight	Body	kg	13.6	13.6	
Sound Pressure Levels (H / M / L)	dB (A)	32 / 29 / 25	35 / 34 / 32	38 / 35 / 32	
Sound Power Levels (H / M / L)	dB (A)	47 / 44 / 41	50 / 48 / 47	52 / 50 / 47	
Power Supply	Ø, V, Hz	1, 220-240, 50	1, 220-240, 50	1, 220-240, 50	
		1, 220, 60	1, 220, 60	1, 220, 60	
Communication Cable	mm ² x No.	1.0-1.5 x 2C	1.0-1.5 x 2C	1.0-1.5 x 2C	
Decoration Panel (Accessory)	Model Name	PT-UUC(Grill) PT-UUD(Panel)	PT-UUC(Grill) PT-UUD(Panel)	PT-UUC(Grill) PT-UUD(Panel)	
	Exterior Color	Noble White	Noble White	Noble White	
	RAL Code	RAL 9003	RAL 9003	RAL 9003	
	Net Dimensions (W x H x D)	mm	1,100 x 34 x 500 1,100 x 34 x 500	1,100 x 34 x 500 1,100 x 34 x 500	
	Net Weight	kg	4.6 / 5.3	4.6 / 5.3	

* Nominal : Performance tested under EN14511

* Rated : Max power input allowed for fan motor

Note : 1. Capacities are based on the following conditions

- Cooling : Indoor temp. 27°C (80.6°F) DB / 19°C (66.2°F) WB, Outdoor temp. 35°C (95°F) DB / 24°C (75.2°F) WB, Interconnecting piping length 7.5m, Level difference of zero

- Heating : Indoor temp. 20°C (68°F) DB / 15°C (59°F) WB, Outdoor temp. 7°C (44.6°F) DB / 6°C (42.8°F) WB, Interconnecting piping length 7.5m, Level difference of zero

2. Due to our policy of innovation some specifications may be changed without notification

3. I.D : 'Internal Diameter'

Accessories

Chassis	ARNU07GTUD4	ARNU09GTUD4	ARNU12GTUD4
Drain Pump		○	
Cassette Cover		-	
Refrigerant Leakage Detector		PRLDNVSO	
EEV Kit		PRGK024A0	
Independent Power Module		PRIPO	
Robot Cleaner		-	
Pre Filter (washable / anti-fungus)		○	
Ion Generator		-	
CO ₂ Sensor		-	
Ventilation Kit		-	
IR Receiver		-	
Zone Controller		-	
Dry Contact (with additional accessory)		PDRYCB000 (1 point contact) PDRYCB300 (8 points for thermostat compatible) PDRYCB400 (2 points input) PDRYCB501 (Modbus)	
External Input (1 point)		○	
Wi-Fi		PWFMD200	

※ ○ : Applied, - : Not applied

Option : Refer to model name in table

ARNU18GTDD4 / ARNU24GTDD4



Model	Unit	ARNU18GTDD4	ARNU24GTDD4	
Cooling Capacity	kW	5.6	7.1	
Heating Capacity	kW	6.3	7.1	
Power Input (H / M / L)	Nominal	38 / 28 / 24	51 / 33 / 26	
	W			
Dimensions (W x H x D)	Body	1,180 x 132 x 450	1,180 x 132 x 450	
	Shipping	1,499 x 259 x 538	1,499 x 259 x 538	
Fan	Type	Cross Flow Fan	Cross Flow Fan	
	Motor Output x Number	W x No.	30 x 1	
	Air Flow Rate (H / M / L)	m ³ /min	13.3 / 12.1 / 10.9	14.6 / 13.3 / 11.5
	Motor type		BLDC	
Air Filter		Pre Filter	Pre Filter	
Pipe Connections	Liquid Side	mm (inch)	Ø6.35(1/4)	
	Gas Side	mm (inch)	Ø12.7(1/2)	
	Drain Pipe (Internal Dia.)	mm (inch)	Ø25(1)	
Weight	Body	kg	15.6	
Sound Pressure Levels (H / M / L)	dB (A)	40 / 37 / 35	43 / 40 / 36	
Sound Power Levels (H / M / L)	dB (A)	56 / 51 / 48	59 / 53 / 50	
Power Supply	Ø, V, Hz	1, 220-240, 50	1, 220-240, 50	
		1, 220, 60	1, 220, 60	
Communication Cable	mm ² x No.	1.0-1.5 x 2C	1.0-1.5 x 2C	
Decoration Panel (Accessory)	Model Name	PT-UTC(Grill) PT-UTD(Panel)	PT-UTC(Grill) PT-UTD(Panel)	
	Exterior Color	Noble White	Noble White	
	RAL Code	RAL 9003	RAL 9003	
	Net Dimensions (W x H x D)	mm	1,420 x 34 x 500 1,420 x 34 x 500	
	Net Weight	kg	5.5 / 6.5	

* Nominal : Performance tested under EN14511

* Rated : Max power input allowed for fan motor

Note : 1. Capacities are based on the following conditions

- Cooling : Indoor temp. 27°C (80.6°F) DB / 19°C (66.2°F) WB, Outdoor temp. 35°C (95°F) DB / 24°C (75.2°F) WB, Interconnecting piping length 7.5m, Level difference of zero

- Heating : Indoor temp. 20°C (68°F) DB / 15°C (59°F) WB, Outdoor temp. 7°C (44.6°F) DB / 6°C (42.8°F) WB, Interconnecting piping length 7.5m, Level difference of zero

2. Due to our policy of innovation some specifications may be changed without notification

3. I.D : 'Internal Diameter'

Accessories

Chassis	ARNU18GTDD4	ARNU24GTDD4
Drain Pump		○
Cassette Cover		-
Refrigerant Leakage Detector		PRLDNVSO
EEV Kit		-
Independent Power Module		PRIPO
Robot Cleaner		-
Pre Filter (washable / anti-fungus)		○
Ion Generator		-
CO ₂ Sensor		-
Ventilation Kit		-
IR Receiver		-
Zone Controller		-
Dry Contact (with additional accessory)		PDRYCB000 (1 point contact) PDRYCB300 (8 points for thermostat compatible) PDRYCB400 (2 points input) PDRYCB503 (Modbus)
External Input (1 point)		○
Wi-Fi		PWFMD200

※ ○ : Applied, - : Not applied

Option : Refer to model name in table

CEILING CONCEALED DUCT



Features & Benefits

- E.S.P. Control Function can Make Air Volume Controlled Easily with Remote Controller.

Key Applications

- Hotel / Conference Center
- Retail / Shopping Center
- School
- Office
- Restaurant
- Church
- Historic Building

	Duct	High	Middle	Low
Smart	Wi-Fi	○	○	○
Energy Efficiency	E.S.P. Control	○	○	○
	Drain Pump	○	○	○
	Timer (on / off)	○	○	○
Comfort	Timer (weekly)	○	○	○
	Two Thermistor Control	○	○	○
	Group Control	○	○	○

※ ○ : Applied, - : Not applied

Wi-Fi Control

Control your air conditioners via using the smart internet devices as Android or iOS based smartphones. This advanced technology provides you the best convenience.

LG SmartThinQ

 Search "LG SmartThinQ" on Google market or Appstore then download the app.
LG SmartThinQ

Access your air conditioner anytime and from anywhere

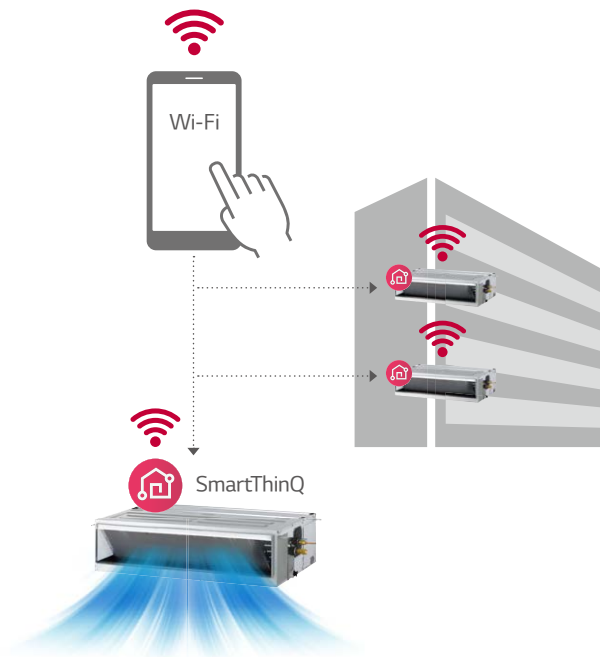

Easy Registration and Log-in

Follow the easy set-up steps that will activate SmartThinQ's impressive feature.

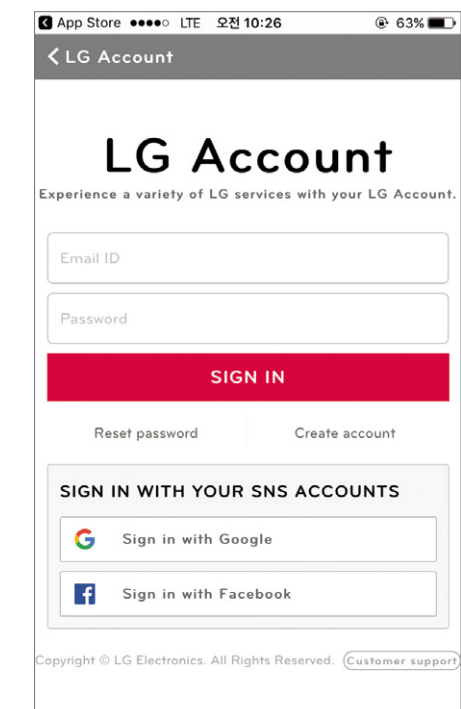

E.S.P.(External Static Pressure) Control

User has an easy access to air volume selection via remote controller secured by the ESP control function. The BLDC motor can control fan speed and air volume regardless of the external static pressure. No additional accessories are necessary to control air flow.

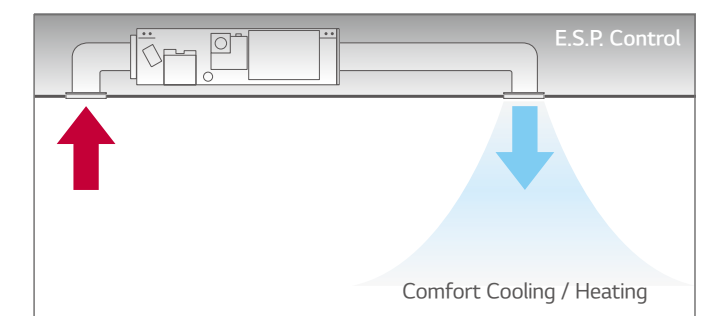
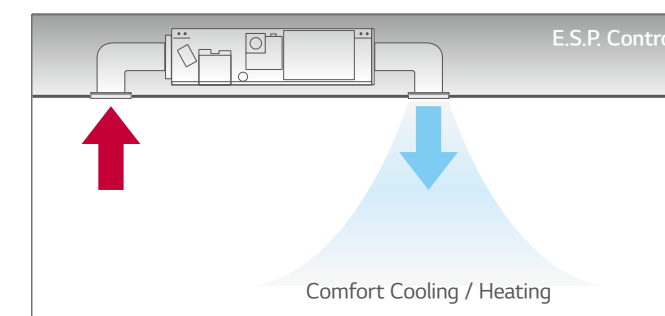

CEILING CONCEALED DUCT

Static Pressure 11 Steps Control

Depending on the installation environment, 4 series ceiling concealed duct is controlled the static pressure to 11 step, for providing comfortable environment suitable for any case scenario.

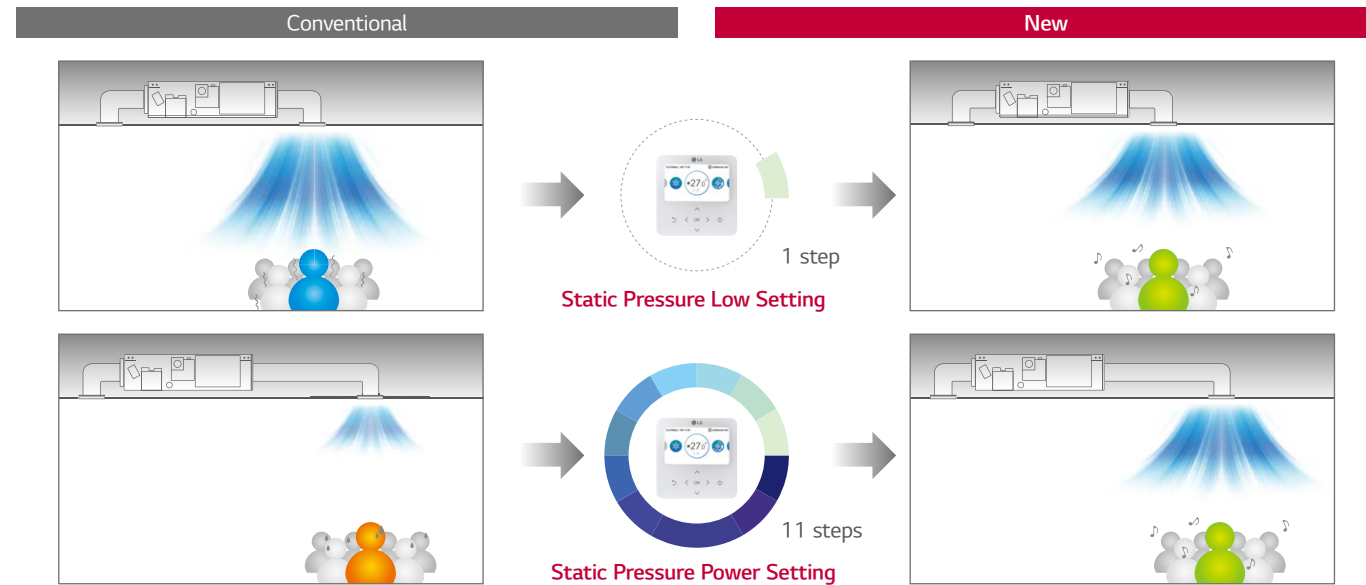

Energy Monitoring (Accumulated Electric Energy Check)

Accumulated electric energy of the indoor unit can be identified with wired remote control, as well as with the central controller. This function is an advantage for energy management.

Install Scene

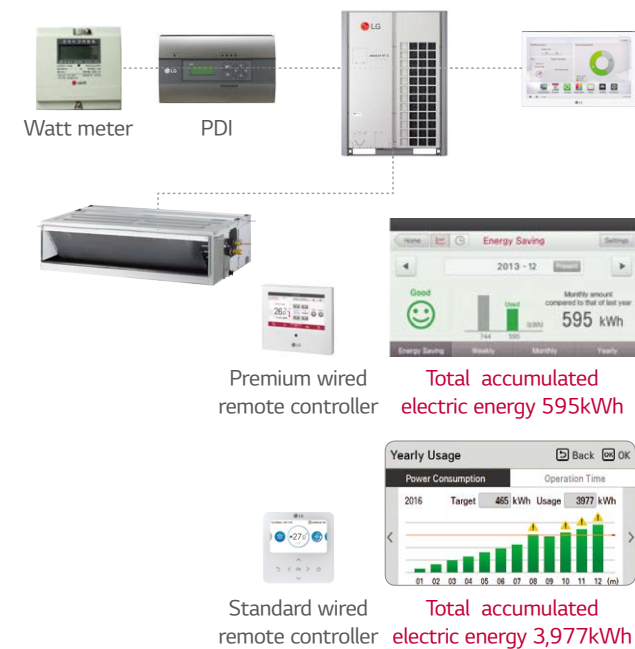

Apply for Multistory Building



* Outdoor unit's accumulated electric energy / using rate of individual indoor unit + indoor unit's accumulated electric energy is displayed in wired remote controller, only when central controller, digital integrating electricity meter and PDI are installed and PDI, outdoor unit and indoor unit are connected with power wire. Only total accumulated electric energy is displayed in standard wired remote controller. In premium wired remote controller, that are displayed into week / month / year.

Operation for Multiple Rooms

Using a spiral duct (embedded or flexible type) and stream chamber, it is possible to operate cooling / heating for several rooms simultaneously.

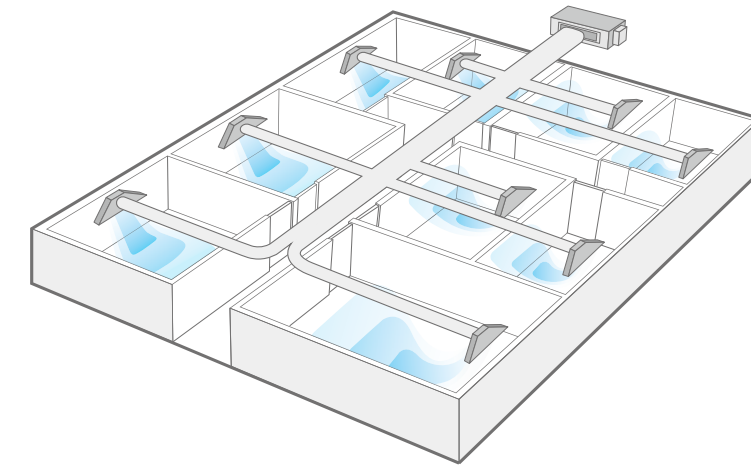

Filter Sign (Remaining Time)

The alarm is activated when the filter needs to be cleaned, and the time remaining for cleaning is displayed on the screen, which is convenient for users.

Remain time until indoor filter cleaning + alarm

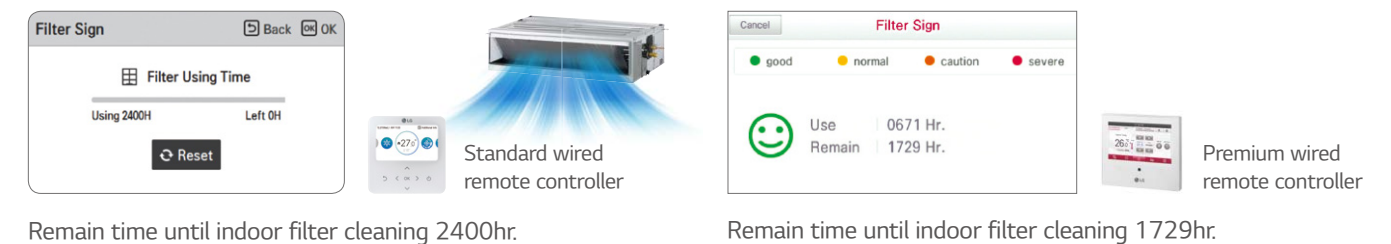

Flexible Installation (Low Static Duct Only)

The low static duct allows the air intake at the rear or bottom under installation condition.

Air intake at the rear or bottom

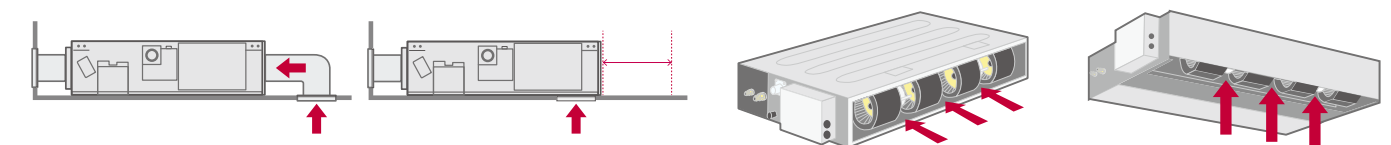

CEILING CONCEALED DUCT

Minimized Height

New mid-static ducts provide ideal solution for installation in limited space.

8 / 10kW

12.5kW

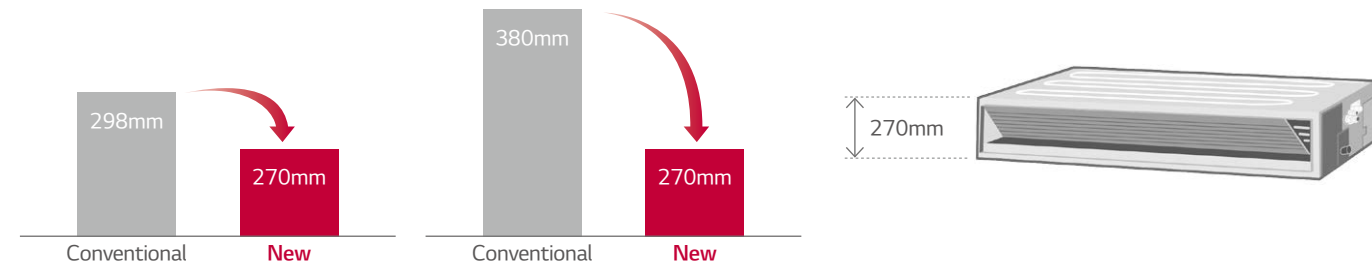

Two Thermistors Control

The indoor temperature can be checked using the thermistors in the remote controller as well as from the indoor unit. There may be a significant difference between ceiling and floor air temperature. Two thermistors can optimise indoor air temperature for a more comfortable environment.

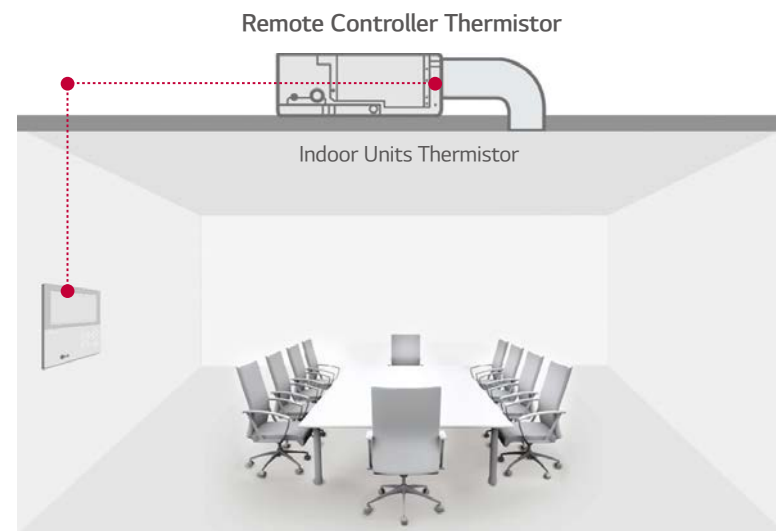

1 Point External Input (On / Off Control)

Indoor units can control external devices without dry contact, so customer can save cost of installation.

Connection between an indoor unit and external devices directly

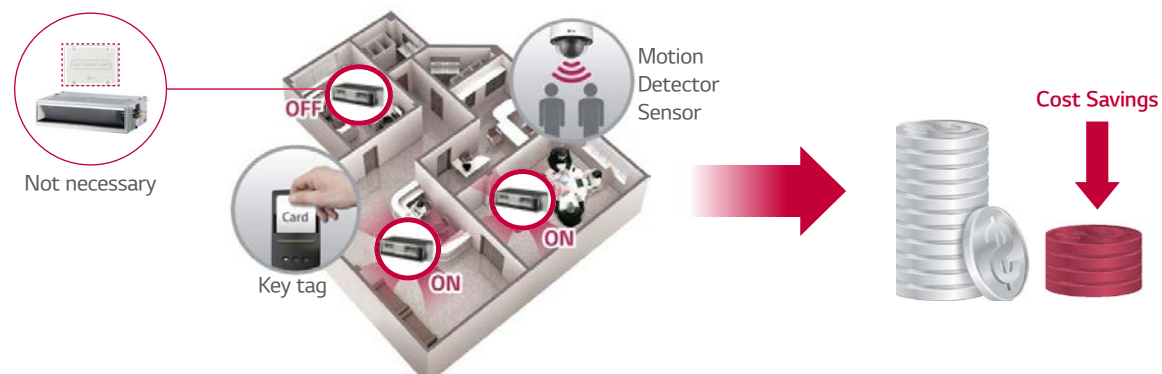

* In case of needing more functions beside on / off control, a dry contact is required to be installed.



MID STATIC

ARNU07GM1A4 / ARNU09GM1A4 / ARNU12GM1A4
ARNU15GM1A4 / ARNU18GM1A4 / ARNU24GM1A4



Model	Unit	ARNU07GM1A4	ARNU09GM1A4	ARNU12GM1A4	ARNU15GM1A4	ARNU18GM1A4	ARNU24GM1A4	
Cooling Capacity	kW	2.2	2.8	3.6	4.5	5.6	7.1	
Heating Capacity	kW	2.5	3.2	4.0	5.0	6.3	8.0	
Power Input (H / M / L)	Nominal	W	39 / 30 / 25	40 / 32 / 26	46 / 38 / 31	67 / 53 / 46	85 / 63 / 55	91 / 74 / 58
	Body	mm	900 x 270 x 700	900 x 270 x 700	900 x 270 x 700	900 x 270 x 700	900 x 270 x 700	900 x 270 x 700
Dimensions (W x H x D)	Shipping	mm	1,100 x 338 x 773	1,100 x 338 x 773	1,100 x 338 x 773	1,100 x 338 x 773	1,100 x 338 x 773	1,100 x 338 x 773
	Type		Sirocco Fan	Sirocco Fan	Sirocco Fan	Sirocco Fan	Sirocco Fan	Sirocco Fan
Fan	Motor Output x Number	W x No.	136 x 1	136 x 1	136 x 1	136 x 1	136 x 1	136 x 1
	Air Flow Rate (H / M / L)	m ³ /min	9.0 / 7.5 / 6.0	9.5 / 7.5 / 6.0	11.0 / 9.0 / 7.0	16.0 / 12.0 / 9.0	17.0 / 14.5 / 12.0	19.0 / 16.0 / 14.0
	External static pressure (High mode)	mmAq (Pa)	6(59)	6(59)	6(59)	6(59)	6(59)	6(59)
	Air Flow Rate (H / M / L) (Standard mode)	m ³ /min	9.0 / 7.5 / 6.0	9.5 / 7.5 / 6.0	11.0 / 9.0 / 7.0	16.0 / 12.0 / 9.0	17.0 / 14.5 / 12.0	19.0 / 16.0 / 14.0
	External static pressure (Standard mode)	mmAq (Pa)	2.5(25)	2.5(25)	2.5(25)	2.5(25)	2.5(25)	2.5(25)
	Motor type		BLDC	BLDC	BLDC	BLDC	BLDC	BLDC
	Air Filter		Pre Filter	Pre Filter	Pre Filter	Pre Filter	Pre Filter	Pre Filter
Pipe Connections	Liquid Side	mm (inch)	Ø6.35(1/4)	Ø6.35(1/4)	Ø6.35(1/4)	Ø6.35(1/4)	Ø9.52(3/8)	
	Gas Side	mm (inch)	Ø12.7(1/2)	Ø12.7(1/2)	Ø12.7(1/2)	Ø12.7(1/2)	Ø15.88(5/8)	
	Drain Pipe (Internal Dia.)	mm (inch)	25(1)	25(1)	Ø25 (1)	Ø25 (1)	Ø25 (1)	
Weight	Body	kg	25.5	25.5	25.5	25.5	26.5	
Sound Pressure Levels (H / M / L)		dB (A)	26 / 24 / 23	27 / 25 / 23	27 / 25 / 23	30 / 27 / 23	31 / 28 / 25	32 / 29 / 26
Sound Power Levels (H / M / L)		dB (A)	55 / 54 / 51	55 / 54 / 52	56 / 54 / 52	59 / 57 / 55	59 / 57 / 55	59 / 58 / 56
Power Supply		Ø, V, Hz	1, 220-240, 50	1, 220-240, 50	1, 220-240, 50	1, 220-240, 50	1, 220-240, 50	1, 220-240, 50
			1, 220, 60	1, 220, 60	1, 220, 60	1, 220, 60	1, 220, 60	1, 220, 60
Communication Cable		mm ² x No.	1.0-1.5 x 2C	1.0-1.5 x 2C	1.0-1.5 x 2C	1.0-1.5 x 2C	1.0-1.5 x 2C	

* Nominal : Performance tested under EN14511

* Rated : Max power input allowed for fan motor

Note : 1. Capacities are based on the following conditions

- Cooling : Indoor temp. 27°C (80.6°F) DB / 19°C (66.2°F) WB, Outdoor temp. 35°C (95°F) DB / 24°C (75.2°F) WB, Interconnecting piping length 7.5m, Level difference of zero

- Heating : Indoor temp. 20°C (68°F) DB / 15°C (59°F) WB, Outdoor temp. 7°C (44.6°F) DB / 6°C (42.8°F) WB, Interconnecting piping length 7.5m, Level difference of zero

2. Due to our policy of innovation some specifications may be changed without notification

3. I.D : 'Internal Diameter'

4. The Sound Pressure test condition is based on 50 Pa for middle static duct.

Accessories

Chassis	ARNU07GM1A4	ARNU09GM1A4	ARNU12GM1A4	ARNU15GM1A4	ARNU18GM1A4	ARNU24GM1A4
Drain Pump				○		
Cassette Cover				-		
Refrigerant Leakage Detector				PRLDNVSO		
EEV Kit				PRGK024A0(-5.6kW)		
Independent Power Module				PRIP0		
Robot Cleaner				-		
Pre Filter (washable / anti-fungus)				○		
Ion Generator				-		
CO ₂ Sensor				-		
Ventilation Kit				-		
IR Receiver				PWLRVN000		
Zone Controller				ABZCA		
Dry Contact (with additional accessory)				PDRYCB000 (1 point contact) PDRYCB300 (8 points for thermostat compatible) PDRYCB400 (2 points input) PDRYCB500 (Modbus)		
External Input (1 point)				○		
Wi-Fi				PWFMD200		

※ ○ : Applied, - : Not applied

Option : Refer to model name in table

ARNU28GM2A4 / ARNU36GM2A4 / ARNU42GM2A4
ARNU48GM3A4 / ARNU54GM3A4



Model	Unit	ARNU28GM2A4	ARNU36GM2A4	ARNU42GM2A4	ARNU48GM3A4	ARNU54GM3A4	
Cooling Capacity	kW	8.2	10.6	12.3	14.1	15.8	
Heating Capacity	kW	9.2	11.9	13.8	15.9	18.0	
Power Input (H / M / L)	Nominal	W	123 / 81 / 57	184 / 123 / 81	231 / 162 / 111	172 / 105 / 65	260 / 215 / 172
	Body	mm	1,250 x 270 x 700	1,250 x 270 x 700	1,250 x 270 x 700	1,250 x 360 x 700	1,250 x 360 x 700
Dimensions (W x H x D)	Shipping	mm	1,450 x 338 x 773	1,450 x 338 x 773	1,450 x 338 x 773	1,450 x 428 x 773	1,450 x 428 x 773
	Type		Sirocco Fan	Sirocco Fan	Sirocco Fan	Sirocco Fan	Sirocco Fan
Fan	Motor Output x Number	W x No.	350 x 1	350 x 1	350 x 1	350 x 1	350 x 1
	Air Flow Rate (H / M / L)	m ³ /min	28.0 / 24.0 / 21.0	32.0 / 28.0 / 24.0	38.0 / 33.0 / 28.0	40.0 / 34.0 / 28.0	50.0 / 45.0 / 40.0
	External static pressure (High mode)	mmAq (Pa)	6(59)	6(59)	6(59)	6(59)	6(59)
	Air Flow Rate (H / M / L) (Standard mode)	m ³ /min	28.0 / 24.0 / 21.0	32.0 / 28.0 / 24.0	38.0 / 33.0 / 28.0	40.0 / 34.0 / 28.0	50.0 / 45.0 / 40.0
	External static pressure (Standard mode)	mmAq (Pa)	5(49)	5(49)	5(49)	5(49)	5(49)
	Motor type		BLDC	BLDC	BLDC	BLDC	BLDC
	Air Filter		Pre Filter	Pre Filter	Pre Filter	Pre Filter	Pre Filter
Pipe Connections	Liquid Side	mm (inch)	Ø9.52(3/8)	Ø9.52(3/8)	Ø9.52(3/8)	Ø9.52(3/8)	
	Gas Side	mm (inch)	Ø15.88(5/8)	Ø15.88(5/8)	Ø15.88(5/8)	Ø19.05(3/4)	
	Drain Pipe (Internal Dia.)	mm (inch)	Ø25 (1)	Ø25 (1)	Ø25 (1)	Ø25 (1)	
Weight	Body	kg	38.0	38.0	39.5	44.0	44.0
Sound Pressure Levels (H / M / L)		dB (A)	36 / 34 / 33	37 / 36 / 34	38 / 37 / 36	39 / 37 / 35	42 / 40 / 39
Sound Power Levels (H / M / L)		dB (A)	59 / 57 / 55	60 / 59 / 57	62 / 61 / 60	63 / 60 / 59	65 / 64 / 62
Power Supply		Ø, V, Hz	1, 220-240, 50	1, 220-240, 50	1, 220-240, 50	1, 220-240, 50	1, 220-240, 50
			1, 220, 60	1, 220, 60	1, 220, 60	1, 220, 60	1, 220, 60
Communication Cable		mm ² x No.	1.0-1.5 x 2C	1.0-1.5 x 2C	1.0-1.5 x 2C	1.0-1.5 x 2C	

* Nominal : Performance tested under EN14511

* Rated : Max power input allowed for fan motor

Note : 1. Capacities are based on the following conditions

- Cooling : Indoor temp. 27°C (80.6°F) DB / 19°C (66.2°F) WB, Outdoor temp. 35°C (95°F) DB / 24°C (75.2°F) WB, Interconnecting piping length 7.5m, Level difference of zero

- Heating : Indoor temp. 20°C (68°F) DB / 15°C (59°F) WB, Outdoor temp. 7°C (44.6°F) DB / 6°C (42.8°F) WB, Interconnecting piping length 7.5m, Level difference of zero

2. Due to our policy of innovation some specifications may be changed without notification

3. I.D : 'Internal Diameter'

4. The Sound Pressure test condition is based on 50 Pa for middle static duct.

Accessories

Chassis	ARNU28GM2A4	ARNU36GM2A4	ARNU42GM2A4	ARNU48GM3A4	ARNU54GM3A4
Drain Pump				○	
Cassette Cover				-	
Refrigerant Leakage Detector				PRLDNVSO	
EEV Kit				-	
Independent Power Module				PRIP0	
Robot Cleaner				-	
Pre Filter (washable / anti-fungus)				○	
Ion Generator				-	
CO ₂ Sensor				-	
Ventilation Kit				-	
IR Receiver				PWLRVN000	
Zone Controller				ABZCA	
Dry Contact (with additional accessory)				PDRYCB000 (1 point contact) PDRYCB300 (8 points for thermostat compatible) PDRYCB400 (2 points input) PDRYCB500 (Modbus)	
External Input (1 point)				○	
Wi-Fi				PWFMD200	

※ ○ : Applied, - : Not applied

Option : Refer to model name in table

HIGH STATIC

ARNU76GB8A4 / ARNU96GB8A4



Model	Unit	ARNU76GB8A4	ARNU96GB8A4
Cooling Capacity	kW	22.4	28.0
Heating Capacity	kW	25.2	31.5
Power Input (H / M / L)	Nominal	765 / 500 / 500	800 / 750 / 750
	W		
Dimensions (W x H x D)	Body	1,562 x 460 x 688	1,562 x 460 x 688
	Shipping	1,806 x 537 x 825	1,806 x 537 x 825
Fan	Type	Sirocco Fan	Sirocco Fan
	Motor Output x Number	W x No.	375 x 2
	Air Flow Rate (H / M / L) (High Mode-Factory Set)	m ³ /min	60.0 / 50.0 / 50.0
	External static pressure (High mode)	mmAq (Pa)	22(216)
	Air Flow Rate (H / M / L) (Standard mode)	m ³ /min	64.0 / 50.0 / 50.0
	External static pressure (Standard mode)	mmAq (Pa)	15(147)
	Motor type		BLDC
Air Filter		Pre Filter	Pre Filter
Pipe Connections	Liquid Side	mm (inch)	Ø9.52(3/8)
	Gas Side	mm (inch)	Ø19.05(3/4)
	Drain Pipe (Internal Dia.)	mm (inch)	Ø25 (1)
Weight	Body	kg	87.0
Power Supply	Ø, V, Hz		1, 220-240, 50
			1, 220, 60
Communication Cable	mm ² x No.		1.0-1.5 x 2C

* Nominal : Performance tested under EN14511

* Rated : Max power input allowed for fan motor

Note : 1. Capacities are based on the following conditions

- Cooling : Indoor temp. 27°C (80.6°F) DB / 19°C (66.2°F) WB, Outdoor temp. 35°C (95°F) DB / 24°C (75.2°F) WB, Interconnecting piping length 7.5m, Level difference of zero
- Heating : Indoor temp. 20°C (68°F) DB / 15°C (59°F) WB, Outdoor temp. 7°C (44.6°F) DB / 6°C (42.8°F) WB, Interconnecting piping length 7.5m, Level difference of zero

2. Due to our policy of innovation some specifications may be changed without notification

3. I.D : 'Internal Diameter'

4. The Sound Pressure test condition is based on 50 Pa for middle static duct.

Accessories

Chassis	ARNU76GB8A4	ARNU96GB8A4
Drain Pump		○
Cassette Cover		-
Refrigerant Leakage Detector		PRLDNVSO
EEV Kit		○
Independent Power Module		PRIP0
Robot Cleaner		-
Pre Filter (washable / anti-fungus)		○
Ion Generator		-
CO ₂ Sensor		-
Ventilation Kit		-
IR Receiver		PWLRVN000
Zone Controller		ABZCA
Dry Contact (with additional accessory)		PDRYCB000 (1 point contact) PDRYCB300 (8 points for thermostat compatible) PDRYCB400 (2 points input) PDRYCB500 (Modbus)
External Input (1 point)		○
Wi-Fi		PWFMD200

※ ○ : Applied, - : Not applied

Option : Refer to model name in table

LOW STATIC

ARNU05GL1G4 / ARNU07GL1G4 / ARNU09GL1G4



Model	Unit	ARNU05GL1G4	ARNU07GL1G4	ARNU09GL1G4
Cooling Capacity	kW	1.7	2.2	2.8
Heating Capacity	kW	1.9	2.5	3.2
Power Input (H / M / L)	Nominal	29 / 26 / 24	31 / 28 / 24	39 / 29 / 24
	W			
Dimensions (W x H x D)	Body	700 x 190 x 700	700 x 190 x 700	700 x 190 x 700
	Shipping	862 x 255 x 781	862 x 255 x 781	862 x 255 x 781
Fan	Type	Sirocco Fan	Sirocco Fan	Sirocco Fan
	Motor Output x Number	W x No.	19 x 1	19 x 1
	Air Flow Rate (H / M / L) (High Mode-Factory Set)	m ³ /min	6.7 / 6.2 / 5.5	7.5 / 6.5 / 5.5
	External static pressure (High mode)	mmAq (Pa)	2.54 (25)	2.54 (25)
	Air Flow Rate (H / M / L) (Standard mode)	m ³ /min	6.7 / 6.2 / 5.5	7.5 / 6.5 / 5.5
	External static pressure (Standard mode)	mmAq (Pa)	0 (0)	0 (0)
	Motor type		BLDC	BLDC
Air Filter		Pre Filter	Pre Filter	Pre Filter
Pipe Connections	Liquid Side	mm (inch)	Ø6.35(1/4)	Ø6.35(1/4)
	Gas Side	mm (inch)	Ø12.7(1/2)	Ø12.7(1/2)
	Drain Pipe (Internal Dia.)	mm (inch)	Ø25 (1)	Ø25 (1)
Weight	Body	kg	17.5	17.5
Sound Pressure Levels (H / M / L)			25 / 24 / 22	26 / 24 / 22
			48 / 46 / 45	50 / 47 / 45
Sound Power Levels (H / M / L)			28 / 25 / 22	53 / 49 / 45
			1, 220 - 240, 50	1, 220 - 240, 50
Power Supply	Ø, V, Hz		1, 220, 60	1, 220, 60
			1, 220, 60	1, 220, 60
Communication Cable	mm ² x No.		1.0-1.5 x 2C	1.0-1.5 x 2C

* Nominal : Performance tested under EN14511

* Rated : Max power input allowed for fan motor

Note : 1. Capacities are based on the following conditions

- Cooling : Indoor temp. 27°C (80.6°F) DB / 19°C (66.2°F) WB, Outdoor temp. 35°C (95°F) DB / 24°C (75.2°F) WB, Interconnecting piping length 7.5m, Level difference of zero
- Heating : Indoor temp. 20°C (68°F) DB / 15°C (59°F) WB, Outdoor temp. 7°C (44.6°F) DB / 6°C (42.8°F) WB, Interconnecting piping length 7.5m, Level difference of zero

2. Due to our policy of innovation some specifications may be changed without notification

3. I.D : 'Internal Diameter'

4. L2, L3 : The Sound Pressure test condition is based on 20 Pa (Static Pressure) as standard.

Accessories

Chassis	ARNU05GL1G4	ARNU07GL1G4	ARNU09GL1G4
Drain Pump		○	
Cassette Cover		-	
Refrigerant Leakage Detector		PRLDNVSO	
EEV Kit		PRGK024A0	
Independent Power Module		PRIP0	
Robot Cleaner		-	
Pre Filter (washable / anti-fungus)		○	
Ion Generator		-	
CO ₂ Sensor		-	
Ventilation Kit		-	
IR Receiver		PWLRVN000	
Zone Controller		ABZCA	
Dry Contact (with additional accessory)		PDRYCB000 (1 point contact) PDRYCB300 (8 points for thermostat compatible) PDRYCB400 (2 points input) PDRYCB500 (Modbus)	
External Input (1 point)		○	
Wi-Fi		PWFMD200	

※ ○ : Applied, - : Not applied

Option : Refer to model name in table

LOW STATIC

ARNU12GL2G4 / ARNU15GL2G4 / ARNU18GL2G4



Model	Unit	ARNU12GL2G4	ARNU15GL2G4	ARNU18GL2G4
Cooling Capacity	kW	3.6	4.5	5.6
Heating Capacity	kW	4.0	5.0	6.3
Power Input (H / M / L)	Nominal	W	41 / 34 / 29	56 / 41 / 34
				71 / 56 / 41
Dimensions (W x H x D)	Body	mm	900 x 190 x 700	900 x 190 x 700
	Shipping	mm	1,062 x 255 x 781	1,062 x 255 x 781
Fan	Type		Sirocco Fan	Sirocco Fan
	Motor Output x Number	W x No.	19 x 1, 5 x 1	19 x 1, 5 x 1
	Air Flow Rate (H / M / L) (High Mode-Factory Set)	m ³ /min	10.0 / 8.5 / 7.0	12.5 / 10.0 / 8.5
	External static pressure (High mode)	mmAq (Pa)	2.54 (25)	2.54 (25)
	Air Flow Rate (H / M / L) (Standard mode)	m ³ /min	10.0 / 8.5 / 7.0	12.5 / 10.0 / 8.5
	External static pressure (Standard mode)	mmAq (Pa)	0 (0)	0 (0)
	Motor type		BLDC	BLDC
Air Filter		Pre Filter	Pre Filter	Pre Filter
Pipe Connections	Liquid Side	mm (inch)	Ø6.35(1/4)	Ø6.35(1/4)
	Gas Side	mm (inch)	Ø12.7(1/2)	Ø12.7(1/2)
	Drain Pipe (Internal Dia.)	mm (inch)	Ø25 (1)	Ø25 (1)
Weight	Body	kg	23.0	23.0
Sound Pressure Levels (H / M / L)		dB(A)	30 / 27 / 25	33 / 30 / 28
Sound Power Levels (H / M / L)		dB(A)	50 / 47 / 46	54 / 51 / 47
Power Supply		∅, V, Hz	1, 220 - 240, 50	1, 220 - 240, 50
			1, 220, 60	1, 220, 60
Communication Cable		mm ² x No.	1.0-1.5 x 2C	1.0-1.5 x 2C

* Nominal : Performance tested under EN14511

* Rated : Max power input allowed for fan motor

Note : 1. Capacities are based on the following conditions

- Cooling : Indoor temp. 27°C (80.6°F) DB / 19°C (66.2°F) WB, Outdoor temp. 35°C (95°F) DB / 24°C (75.2°F) WB, Interconnecting piping length 7.5m, Level difference of zero

- Heating : Indoor temp. 20°C (68°F) DB / 15°C (59°F) WB, Outdoor temp. 7°C (44.6°F) DB / 6°C (42.8°F) WB, Interconnecting piping length 7.5m, Level difference of zero

2. Due to our policy of innovation some specifications may be changed without notification

3. I.D : 'Internal Diameter'

4. L2, L3 : The Sound Pressure test condition is based on 20 Pa (Static Pressure) as standard.

Accessories

Chassis	ARNU12GL2G4	ARNU15GL2G4	ARNU18GL2G4
Drain Pump		○	
Cassette Cover		-	
Refrigerant Leakage Detector		PRLDNVSO	
EEV Kit		○	
Independent Power Module		PRIP0	
Robot Cleaner		-	
Pre Filter (washable / anti-fungus)		○	
Ion Generator		-	
CO ₂ Sensor		-	
Ventilation Kit		-	
IR Receiver		PWLRVN000	
Zone Controller		ABZCA	
Dry Contact (with additional accessory)		PDRYCB000 (1 point contact) PDRYCB300 (8 points for thermostat compatible) PDRYCB400 (2 points input) PDRYCB500 (Modbus)	
External Input (1 point)		○	
Wi-Fi		PWFMD200	

※ ○ : Applied, - : Not applied

Option : Refer to model name in table

ARNU21GL3G4 / ARNU24GL3G4



Model	Unit	ARNU21GL3G4	ARNU24GL3G4
Cooling Capacity	kW	6.2	7.1
Heating Capacity	kW	7.0	8.0
Power Input (H / M / L)	Nominal	W	72 / 53 / 48
			103 / 63 / 48
Dimensions (W x H x D)	Body	mm	1,100 x 190 x 700
	Shipping	mm	1,262 x 255 x 781
Fan	Type		Sirocco Fan
	Motor Output x Number	W x No.	19 x 2
	Air Flow Rate (H / M / L) (High Mode-Factory Set)	m ³ /min	17.5 / 14.0 / 12.0
	External static pressure (High mode)	mmAq (Pa)	2.54 (25)
	Air Flow Rate (H / M / L) (Standard mode)	m ³ /min	17.5 / 14.0 / 12.0
	External static pressure (Standard mode)	mmAq (Pa)	0 (0)
	Motor type		BLDC
Air Filter		Pre Filter	Pre Filter
Pipe Connections	Liquid Side	mm (inch)	Ø9.52(3/8)
	Gas Side	mm (inch)	Ø15.88(5/8)
	Drain Pipe (Internal Dia.)	mm (inch)	Ø25 (1)
Weight	Body	kg	27.0
Sound Pressure Levels (H / M / L)		dB(A)	35 / 29 / 28
Sound Power Levels (H / M / L)		dB(A)	59 / 55 / 54
Power Supply		∅, V, Hz	1, 220 - 240, 50
			1, 220, 60
Communication Cable		mm ² x No.	1.0-1.5 x 2C

* Nominal : Performance tested under EN14511

* Rated : Max power input allowed for fan motor

Note : 1. Capacities are based on the following conditions

- Cooling : Indoor temp. 27°C (80.6°F) DB / 19°C (66.2°F) WB, Outdoor temp. 35°C (95°F) DB / 24°C (75.2°F) WB, Interconnecting piping length 7.5m, Level difference of zero

- Heating : Indoor temp. 20°C (68°F) DB / 15°C (59°F) WB, Outdoor temp. 7°C (44.6°F) DB / 6°C (42.8°F) WB, Interconnecting piping length 7.5m, Level difference of zero

2. Due to our policy of innovation some specifications may be changed without notification

3. I.D : 'Internal Diameter'

4. L2, L3 : The Sound Pressure test condition is based on 20 Pa (Static Pressure) as standard.

Accessories

Chassis	ARNU21GL3G4	ARNU24GL3G4
Drain Pump		○
Cassette Cover		-
Refrigerant Leakage Detector		PRLDNVSO
EEV Kit		-
Independent Power Module		PRIP0
Robot Cleaner		-
Pre Filter (washable / anti-fungus)		○
Ion Generator		-
CO ₂ Sensor		-
Ventilation Kit		-
IR Receiver		PWLRVN000
Zone Controller		ABZCA
Dry Contact (with additional accessory)		PDRYCB000 (1 point contact) PDRYCB300 (8 points for thermostat compatible) PDRYCB400 (2 points input) PDRYCB500 (Modbus)
External Input (1 point)		○
Wi-Fi		PWFMD200

※ ○ : Applied, - : Not applied

Option : Refer to model name in table

HIGH SENSIBLE

ARNU07GM2A4 / ARNU09GM2A4 / ARNU12GM2A4 / ARNU15GM2A4
ARNU28GM2A4 / ARNU36GM2A4 / ARNU42GM2A4



Model	Unit	ARNU07GM2A4	ARNU09GM2A4	ARNU12GM2A4	ARNU15GM2A4	ARNU28GM2A4	ARNU36GM2A4	ARNU42GM2A4	
Cooling Capacity	kW	2.2	2.8	3.6	4.5	8.2	10.6	12.3	
Heating Capacity	kW	2.5	3.2	4.0	5.0	9.2	11.9	13.8	
Power Input	Nominal W	30	30	30	30	123	184	231	
Dimensions (W x H x D)	Body	1,250 x 270 x 700	1,250 x 270 x 700	1,250 x 270 x 700	1,250 x 270 x 700	1,250 x 270 x 700	1,250 x 270 x 700	1,250 x 270 x 700	
	Type	Sirocco Fan	Sirocco Fan	Sirocco Fan	Sirocco Fan	Sirocco Fan	Sirocco Fan	Sirocco Fan	
Fan	Motor Output x Number	W	350 x 1	350 x 1	350 x 1	350 x 1	350 x 1	350 x 1	
	Air Flow Rate (H / M / L) (High Mode-Factory Set) External Static Pressure	CMM	12.8 / 7.7 / 7.7	12.8 / 7.7 / 7.7	13.6 / 8.7 / 8.7	13.6 / 8.7 / 8.7	28.0 / 24.0 / 21.0	32.0 / 28.0 / 24.0	38.0 / 33.0 / 28.0
		cfm	452 / 272 / 272	452 / 272 / 272	480 / 307 / 307	480 / 307 / 307	989 / 848 / 742	1,130 / 989 / 848	1,342 / 1,165 / 989
		mmAq(Pa)	6(59)	6(59)	6(59)	6(59)	6(59)	6(59)	6(59)
	Air Flow Rate (H / M / L) (Standard Mode) External Static Pressure	CM	12.8 / 7.7 / 7.7	12.8 / 7.7 / 7.7	13.6 / 8.7 / 8.7	13.6 / 8.7 / 8.7	28.0 / 24.0 / 21.0	32.0 / 28.0 / 24.0	38.0 / 33.0 / 28.0
		cfm	452 / 272 / 272	452 / 272 / 272	480 / 307 / 307	480 / 307 / 307	989 / 848 / 742	1,130 / 989 / 848	1,342 / 1,165 / 989
mmAq(Pa)		5(49)	5(49)	5(49)	5(49)	5(49)	5(49)	5(49)	
Motor Type		BLDC	BLDC	BLDC	BLDC	BLDC	BLDC	BLDC	
Air Filter		-	-	-	-	-	-	-	
Safety Device		Fuse	Fuse	Fuse	Fuse	Fuse	Fuse	Fuse	
Pipe Connections	Liquid Side	mm(inch)	Ø9.52(3/8)	Ø9.52(3/8)	Ø9.52(3/8)	Ø9.52(3/8)	Ø9.52(3/8)	Ø9.52(3/8)	
	Gas Side	mm(inch)	Ø15.88(5/8)	Ø15.88(5/8)	Ø15.88(5/8)	Ø15.88(5/8)	Ø15.88(5/8)	Ø15.88(5/8)	
	Drain Pipe(Internal Dia.)	mm(inch)	25(1)	25(1)	25(1)	25(1)	25(1)	25(1)	
Net Weight	Body kg(lbs)	38.0(84)	38.0(84)	38.0(84)	38.0(84)	38.0(84)	38.0(84)	39.5(87)	
Sound Pressure Levels (H / M / L)	dB(A)	38 / 36 / 36	38 / 36 / 36	38 / 36 / 36	38 / 36 / 36	36 / 34 / 33	37 / 36 / 34	38 / 37 / 36	
Sound Power Levels (H / M / L)	dB(A)	54 / 53 / 53	54 / 53 / 53	53 / 52 / 52	53 / 52 / 52	59 / 57 / 55	60 / 59 / 57	62 / 61 / 60	
Power Supply	Ø, V, Hz		1, 220-240, 50	1, 220-240, 50	1, 220-240, 50	1, 220-240, 50	1, 220-240, 50	1, 220-240, 50	
			1, 220, 60	1, 220, 60	1, 220, 60	1, 220, 60	1, 220, 60	1, 220, 60	
Transmission Cable		1.0-1.5 x 2C	1.0-1.5 x 2C	1.0-1.5 x 2C	1.0-1.5 x 2C	1.0-1.5 x 2C	1.0-1.5 x 2C	1.0-1.5 x 2C	

* Nominal : Performance tested under EN14511
 * Rated : Max power input allowed for fan motor
 Note : 1. Capacities are based on the following conditions
 - Cooling : Indoor temp. 27°C (80.6°F) DB / 19°C (66.2°F) WB, Outdoor temp. 35°C (95°F) DB / 24°C (75.2°F) WB, Interconnecting piping length 7.5m, Level difference of zero
 - Heating : Indoor temp. 20°C (68°F) DB / 15°C (59°F) WB, Outdoor temp. 7°C (44.6°F) DB / 6°C (42.8°F) WB, Interconnecting piping length 7.5m, Level difference of zero
 2. Due to our policy of innovation some specifications may be changed without notification
 3. I.D : 'Internal Diameter'

* These models will be developed until February (After the completion of the development, the air flow and noise information may be partially changed.)

Accessories

Chassis	ARNU07GM2A4	ARNU09GM2A4	ARNU12GM2A4	ARNU15GM2A4	ARNU28GM2A4	ARNU36GM2A4	ARNU42GM2A4
Drain Pump				○			
Cassette Cover				-			
Refrigerant Leakage Detector				PRLDNVSO			
EEV Kit				-			
Independent Power Module				PRIP0			
Robot Cleaner				-			
Pre Filter (washable / anti-fungus)				○			
Ion Generator				-			
CO ₂ Sensor				-			
Ventilation Kit				-			
IR Receiver				PWLRVN000			
Zone Controller				ABZCA			
Dry Contact (with additional accessory)				PDRYCB000 (1 point contact) PDRYCB300 (8 points for thermostat compatible) PDRYCB400 (2 points input) PDRYCB500 (Modbus)			
External Input (1 point)				○			
Wi-Fi				PWFMD200			

※ ○ : Applied, - : Not applied
 Option : Refer to model name in table

ARNU18GM3A4 / ARNU24GM3A4 / ARNU28GM3A4



Model	Unit	ARNU18GM3A4	ARNU24GM3A4	ARNU28GM3A4	
Cooling Capacity	kW	5.6	7.1	8.2	
Heating Capacity	kW	6.3	8.0	9.2	
Power Input	Nominal W	50	75	75	
Dimensions (W x H x D)	Body	mm	Galvanized Steel Plate	Galvanized Steel Plate	
	Type		1,250 x 360 x 700	1,250 x 360 x 700	
Fan	Motor Output x Number	W	Sirocco Fan	Sirocco Fan	
	Air Flow Rate (H / M / L) (High Mode-Factory Set) External Static Pressure	CMM	350 x 1	350 x 1	350 x 1
		cfm	32.7 / 26.7 / 23.0	35.5 / 30.6 / 26.2	35.5 / 30.6 / 26.2
		mmAq(Pa)	1,155 / 943 / 812	1,254 / 1,081 / 925	1,254 / 1,081 / 925
	Air Flow Rate (H / M / L) (Standard Mode) External Static Pressure	CM	6(59)	6(59)	6(59)
		cfm	32.7 / 26.7 / 23.0	35.5 / 30.6 / 26.2	35.5 / 30.6 / 26.2
mmAq(Pa)		1,155 / 943 / 812	1,254 / 1,081 / 925	1,254 / 1,081 / 925	
Motor Type		5(49)	5(49)	5(49)	
Air Filter		BLDC	BLDC	BLDC	
Safety Device		-	-	-	
Pipe Connections	Liquid Side	mm(inch)	Ø9.52(3/8)	Ø9.52(3/8)	
	Gas Side	mm(inch)	Ø15.88(5/8)	Ø15.88(5/8)	
	Drain Pipe(Internal Dia.)	mm(inch)	25(1)	25(1)	
Net Weight	Body kg(lbs)	44(97)	44(97)	44(97)	
Sound Pressure Levels (H / M / L)	dB(A)	39 / 37 / 36	40 / 38 / 37	40 / 38 / 37	
Sound Power Levels (H / M / L)	dB(A)	53 / 52 / 51	54 / 53 / 52	54 / 53 / 52	
Power Supply	Ø, V, Hz		1, 220-240, 50	1, 220-240, 50	
			1, 220, 60	1, 220, 60	
Transmission Cable		1.0-1.5 x 2C	1.0-1.5 x 2C	1.0-1.5 x 2C	

* Nominal : Performance tested under EN14511
 * Rated : Max power input allowed for fan motor
 Note : 1. Capacities are based on the following conditions
 - Cooling : Indoor temp. 27°C (80.6°F) DB / 19°C (66.2°F) WB, Outdoor temp. 35°C (95°F) DB / 24°C (75.2°F) WB, Interconnecting piping length 7.5m, Level difference of zero
 - Heating : Indoor temp. 20°C (68°F) DB / 15°C (59°F) WB, Outdoor temp. 7°C (44.6°F) DB / 6°C (42.8°F) WB, Interconnecting piping length 7.5m, Level difference of zero
 2. Due to our policy of innovation some specifications may be changed without notification
 3. I.D : 'Internal Diameter'

* These models will be developed until February (After the completion of the development, the air flow and noise information may be partially changed.)

Accessories

Chassis	ARNU18GM3A4	ARNU24GM3A4	ARNU28GM3A4
Drain Pump			○
Cassette Cover			-
Refrigerant Leakage Detector			PRLDNVSO
EEV Kit			-
Independent Power Module			PRIP0
Robot Cleaner			-
Pre Filter (washable / anti-fungus)			○
Ion Generator			-
CO ₂ Sensor			-
Ventilation Kit			-
IR Receiver			PWLRVN000
Zone Controller			ABZCA
Dry Contact (with additional accessory)			PDRYCB000 (1 point contact) PDRYCB300 (8 points for thermostat compatible) PDRYCB400 (2 points input) PDRYCB500 (Modbus)
External Input (1 point)			○
Wi-Fi			PWFMD200

※ ○ : Applied, - : Not applied
 Option : Refer to model name in table

FRESH AIR INTAKE UNIT

Fresh Outdoor Air Supply

The LG Fresh Air Intake Unit (FAU) is the alternative solution for ventilation, which supplies the fresh outdoor air indoors as well as being able to cool and heat air inside simultaneously. It means the indoor space can have positive air pressure consistently, which can block cold, hot or contaminated air from outside.

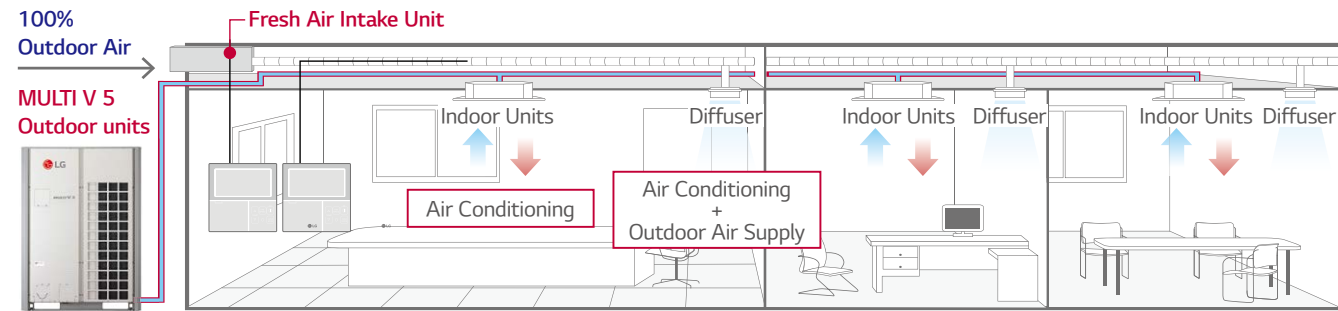

Economic Operation

Using the cooling and heating can save costs by blowing the natural outdoor air inside when the season change.

Spring Season

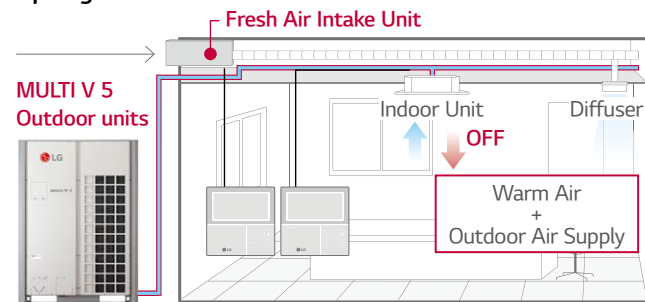

Autumn Season

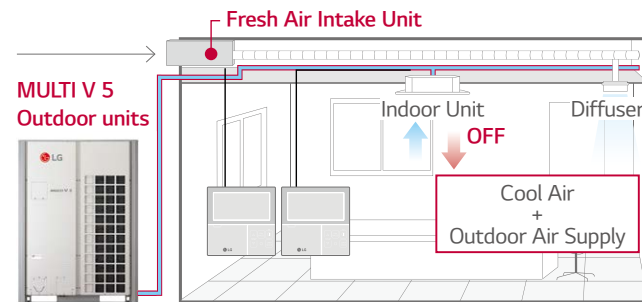

Installation Scene

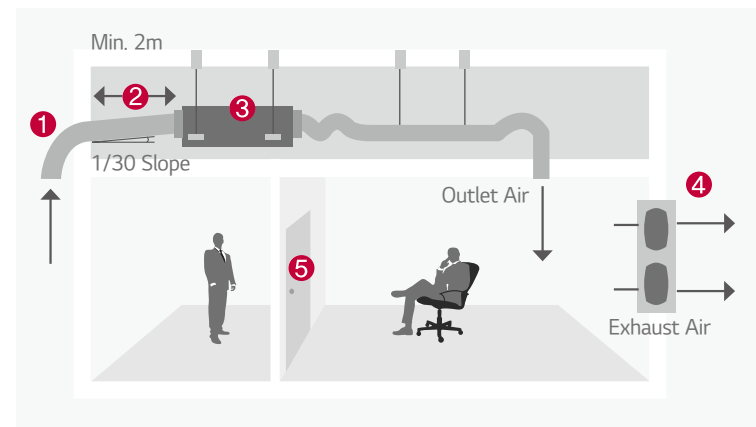

- ① Inlet Hood
- ② Intake Air Duct
- ③ Fresh Air Intake Unit
- ④ Exhaust Fan
- ⑤ Door

ARNU76GB8Z4 / ARNU96GB8Z4



Model	Unit	ARNU76GB8Z4	ARNU96GB8Z4
Cooling Capacity	kW	22.4	28.0
Heating Capacity	kW	21.4	26.7
Power Input (H / M / L)			
Nominal	W	230 / 200 / 200	360 / 230 / 230
Dimensions (W x H x D)			
Body	mm	1,562 x 460 x 688	1,562 x 460 x 688
Shipping	mm	1,806 x 537 x 825	1,806 x 537 x 825
Fan			
Type		Sirocco Fan	Sirocco Fan
Motor Output x Number	W x No.	375 x 1	375 x 1
Air Flow Rate (H / M / L) (High Mode-Factory Set)	m ³ /min	23.7 / 13.2 / 13.2	35.7 / 23.7 / 23.7
External static pressure	mmAq (Pa)	22(216)	22(216)
Motor Type		BLDC	BLDC
Air Filter		Long Life Filter	Long Life Filter
Pipe Connections			
Liquid Side	mm(inch)	Ø9.52(3/8)	Ø9.52(3/8)
Gas Side	mm(inch)	Ø19.05(3/4)	Ø22.2(7/8)
Drain Pipe (Internal Dia.)	mm(inch)	Ø25 (1)	Ø25 (1)
Weight	kg	73.0	73.0
Sound Pressure Levels (H / M / L)	dB(A)	45 / 43 / 43	47 / 45 / 45
Sound Power Levels (H / M / L)	dB(A)	70 / 67 / 67	72 / 70 / 70
Power Supply	Ø, V, Hz	1, 220 - 240, 50	1, 220 - 240, 50
Communication Cable	mm ² x No.	1, 220, 60	1, 220, 60
		1.0-1.5 x 2C	1.0-1.5 x 2C

* Nominal : Performance tested under EN14511

* Rated : Max power input allowed for fan motor

Note : 1. Capacities are based on the following conditions

- Cooling : Outdoor temp. 35°C (95°F) DB / 24°C (75.2°F) WB, Interconnecting piping length 7.5m, Level difference of zero

- Heating : Outdoor temp. 7°C (44.6°F) DB / 6°C (42.8°F) WB, Interconnecting piping length 7.5m, Level difference of zero

2. Capacities are net capacities

3. Noise Level is under standard mode [For actual High Mode (Factory set) condition, Noise Level may exceed the standard level by 1.5db (A)]

4. Due to our policy of innovation some specifications may be changed without prior notification.

5. I.D : 'Internal Diameter'

CAUTION

1. Operation range (Cooling : 5°C ~ 43°C, Heating : -5°C ~ 43°C)
2. Installation of exhaust fan is recommended for a sealed room.
3. Indoor Unit Connection

No	Connection Condition	Combination
1	Fresh air intake units only are connected with outdoor units	1) The total capacity of fresh air intake unit should be 50 ~ 100% of outdoor unit. 2) The max quantity of fresh air intake is 4 units.
2	Mixture connection with general indoor unit and fresh intake units	1) The total capacity of indoor units (Standard Indoor Unit + Fresh Air Intake Unit) should be 50 ~ 100% of outdoor unit. 2) The total capacity of fresh air intake unit should be less than 30% of the total capacity of indoor units.

Accessories

Chassis	ARNU76GB8Z4	ARNU96GB8Z4
Drain Pump		○
Cassette Cover		-
Refrigerant Leakage Detector		PRLDNVSO
EEV Kit		-
Independent Power Module		PRIP0
Robot Cleaner		-
Pre Filter (washable / anti-fungus)		○
Ion Generator		-
CO ₂ Sensor		-
Ventilation Kit		-
IR Receiver		PWLRVN000
Zone Controller		-
Dry Contact (with additional accessory)		PDRYCB000 (1 point contact) PDRYCB300 (8 points for thermostat compatible) PDRYCB400 (2 points input) PDRYCB500 (Modbus)
External Input (1 point)		○
Wi-Fi		PWFMD200

※ ○ : Applied, - : Not applied

Option : Refer to model name in table

FLOOR STANDING UNIT

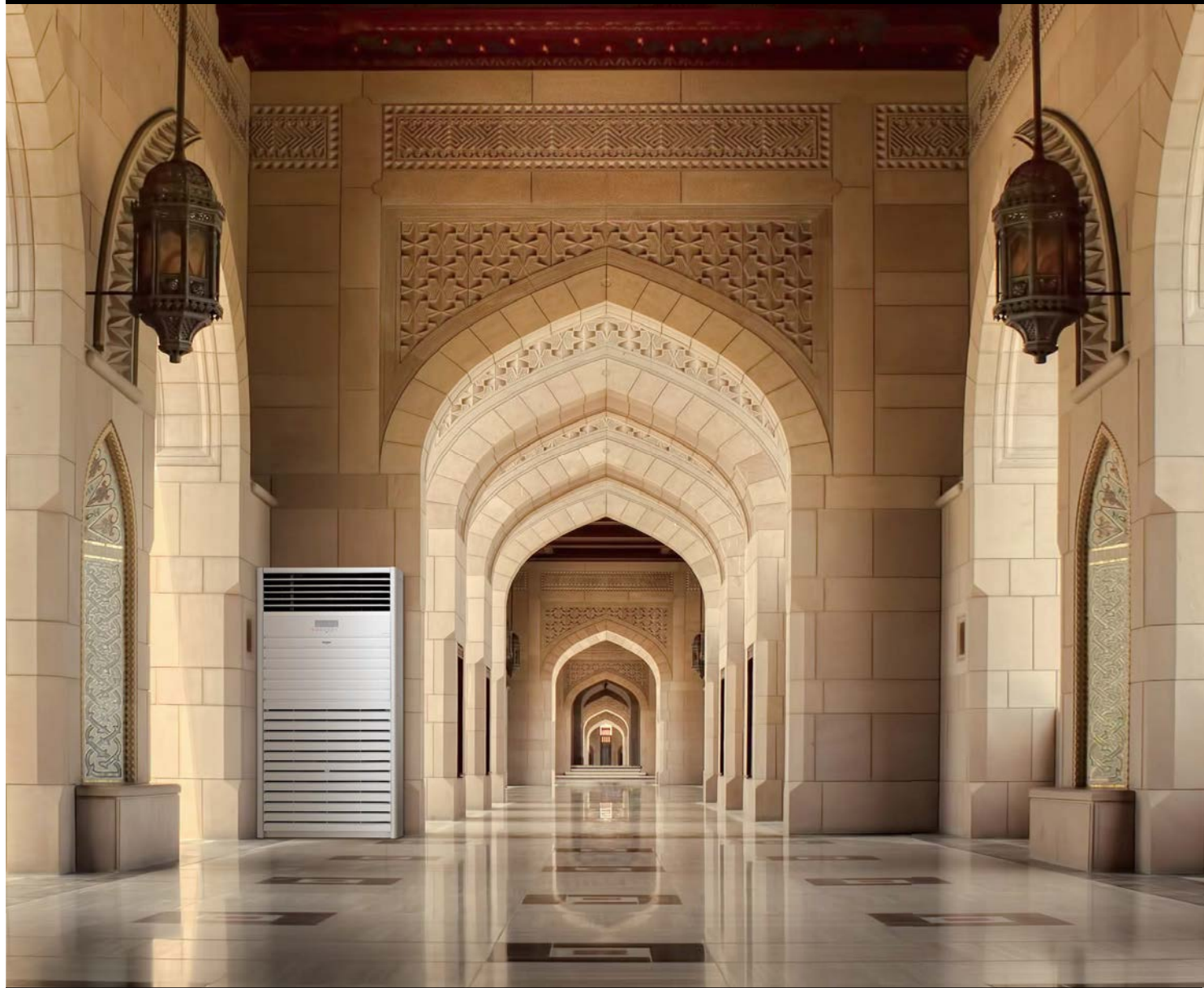

Features & Benefits

- The powerful air speed and volume means the air flow can reach up to 15m away from the air conditioner.

Key Applications

- Retail
- Shop
- Office
- Restaurant

Simple & Elegant Design

With its stylish design, LG's new floor standing air conditioner enhances the overall indoor interior



Less Temperature Difference

Power cooling and heating will minimize the temperature difference between upper part and lower part of the room

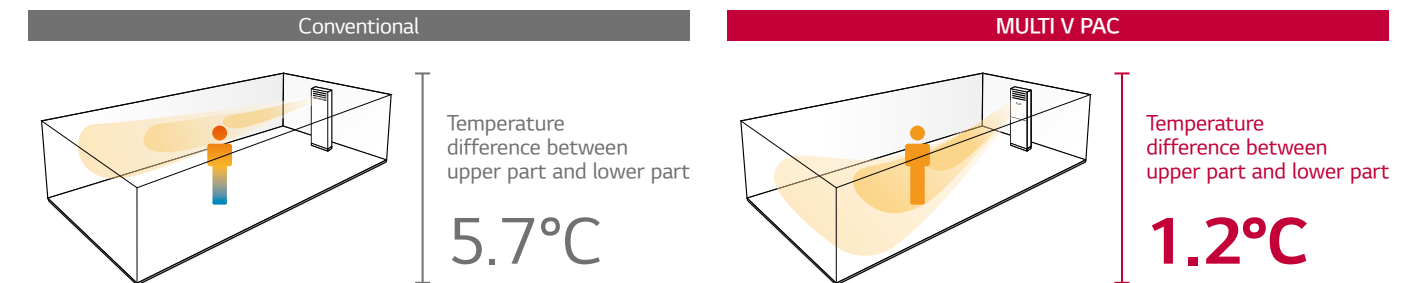

* Temperature difference between upper part and lower part
 * Test Condition : Indoor temperature 12°C, Outdoor temperature 7°C, Setting Temperature 30°C
 * Measure Condition : After 3 hours heating operation (average temperature)

15m Long Power Cooling

The new LG floor standing unit is efficient for using in large areas due to its powerful cooling and heating operation. The powerful air speed and volume means the air flow can reach up to 15m away from the air conditioner



* Based on 131.8m²

Type	Floor Standing
Air Flow (m ³ /min)	37
Air Speed (m/s)	4.5

FLOOR STANDING UNIT

ARNU48GPTA4
ARNU96GPFA4



Model	Independent Unit		ARNU48GPTA4	ARNU96GPFA4	
Capacity	Cooling	Nom	kW	14.1	28.0
	Heating	Nom	kW	15.9	31.5
Power Input	Cooling	Nom	w	250	400
	Heating	Nom	w	250	400
	Cooling	Rated	w	250	400
	Heating	Rated	w	250	400
Power Supply		Ø / V / Hz	1 / 220 / 60	1 / 220 / 60	
Airflow Rate	Cooling	Power / H / M / L	m³/min	37 / 33 / 28 / 24	68 / 61 / - / 50
	Heating	Power / H / M / L	m³/min	37 / 33 / 28 / 24	68 / 61 / - / 50
Sound Pressure		Power / H / M / L	dBA	54 / 51 / 49 / 45	60 / 57 / - / 53
Dimension	Body	W x H x D	mm	590 x 1,840 x 440	1,050 x 1,880 x 495
Net Weight			kg	48.0	113.0
Piping Connection	Liquid		mm	9.52	9.52
	Gas		mm	15.88	22.2
	Drain	I.D	mm	-	-

* This product contains Fluorinated Greenhouse Gases. (R410A)

* Nom. : Performance tested under EN14511

* Rated : Max power input allowed for fan motor

Note : 1. Capacities are based on the following conditions

- Cooling : Indoor temp. 27°C (80.6°F) DB / 19°C (66.2°F) WB, Outdoor temp. 35°C (95°F) DB / 24°C (75.2°F) WB, Interconnecting piping length 7.5m, Level difference of zero

- Heating : Indoor temp. 20°C (68°F) DB / 15°C (59°F) WB, Outdoor temp. 7°C (44.6°F) DB / 6°C (42.8°F) WB, Interconnecting piping length 7.5m, Level difference of zero

2. Due to our policy of innovation some specifications may be changed without notification

3. I.D : 'Internal Diameter'

Accessories

Model		ARNU07GCE*4	ARNU09GCE*4
Dry Contact	Simple (1 Contact Point with Case)		PDRYCB000
	2 Contact Point		PDRYCB400
	For Thermostat (On-Off / Mode / Fan Speed)		PDRYCB300
	Modbus Communication		PDRYCB500
EEV Kit for MULTI V Indoor			-
IR Receiver			PWLRVN000

Wired Remote Controller							Wireless Remote Controller
Premium	Standard III		Standard II		Simple	Simple for Hotel	
PREMTA000 PREMTA000A PREMTA000B	PREMTB100 (White)	PREMTBB10 (Black)	PREMTB001 (White)	PREMTBB01 (Black)	PQRCVCL0Q (Black) PQRCVCL0QW (White)	PQRCHCA0Q (Black) PQRCHCA0QW (White)	PQWRHQ0FDB

CEILING SUSPENDED UNIT



Features & Benefits

- Ideal Solution for Commercial Spaces with Solid Ceilings with Its Stunning V-shaped Design and Black Vane, LG's 2 Years Ceiling-suspended Air Conditioner Exudes Modern Elegance Appropriate for Any Space.
- The Powerful Air Speed and Volume Means the Air Flow can Reach Up to 15m Away from the Air Conditioner.

Key Applications

- Retail
- Shop
- Office
- Restaurant

	Ceilings	Ceiling & Floor Convertible Unit	Ceiling Suspended Unit
Smart	Wi-Fi	○	○
Fast Cooling & Heating	Jet Cool	○	○
	Sleep mode	○	○
Comfort	Timer (on / off)	○	○
	Timer (weekly)	○	○
	Two thermistor control	○	○
	Group control	○	○

※ ○ : Applied, - : Not applied

Wi-Fi Control

Control your air conditioners via using the smart internet devices as Android or iOS based smartphones. This advanced technology provides you the best convenience.

LG SmartThinQ

 Search "LG SmartThinQ" on Google market or Appstore then download the app.
LG SmartThinQ

Access your air conditioner anytime and from anywhere

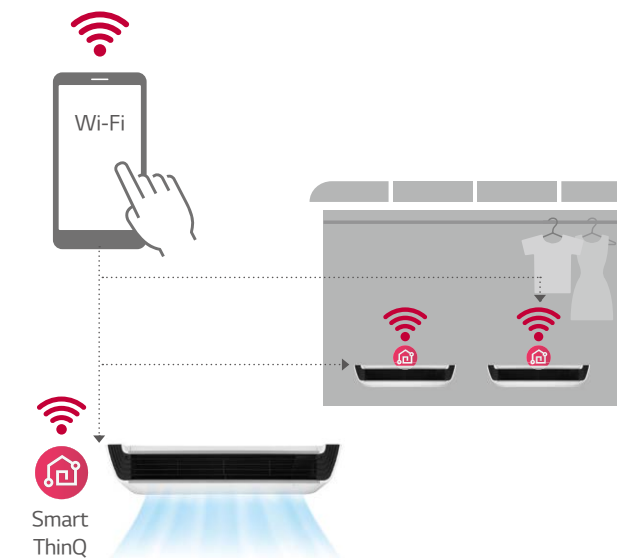

Easy Registration and Log-in

Follow the easy set-up steps that will activate SmartThinQ's impressive feature.

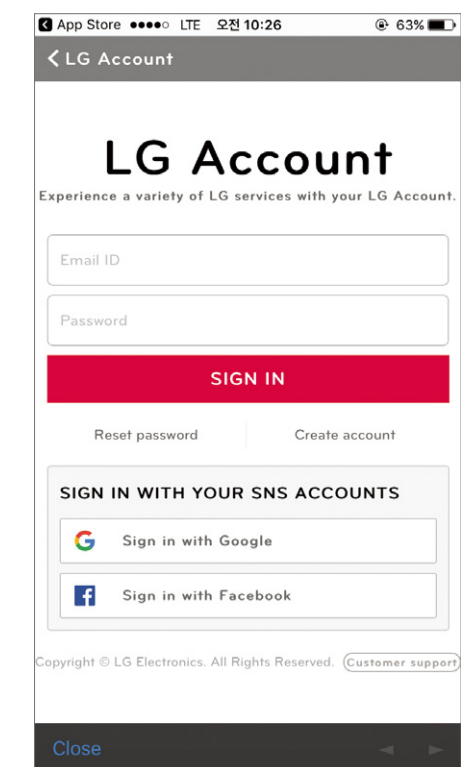

Differentiated Design

With its stunning V-shaped design and black vane, LG's new ceiling-suspended air conditioner exudes modern elegance appropriate for any space. The tasteful aesthetics of the air conditioner helped earn it the iF Design Award.



CEILING SUSPENDED UNIT

Powerful Cooling & Heating

High ceiling mode provides powerful cooling and heating up to 4.2m in height, from ceiling to floor.



One Touch & 2 Piece Filter

Easy in / out filter structure as well as a simplified two-piece filter, which slides out for easy cleaning and maintenance.

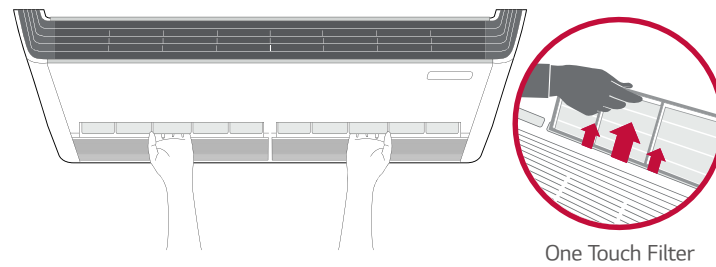

Two Thermistors Control

Users can purchase a wired remote controller that includes a second thermistor, allowing for temperature checks from multiple locations.

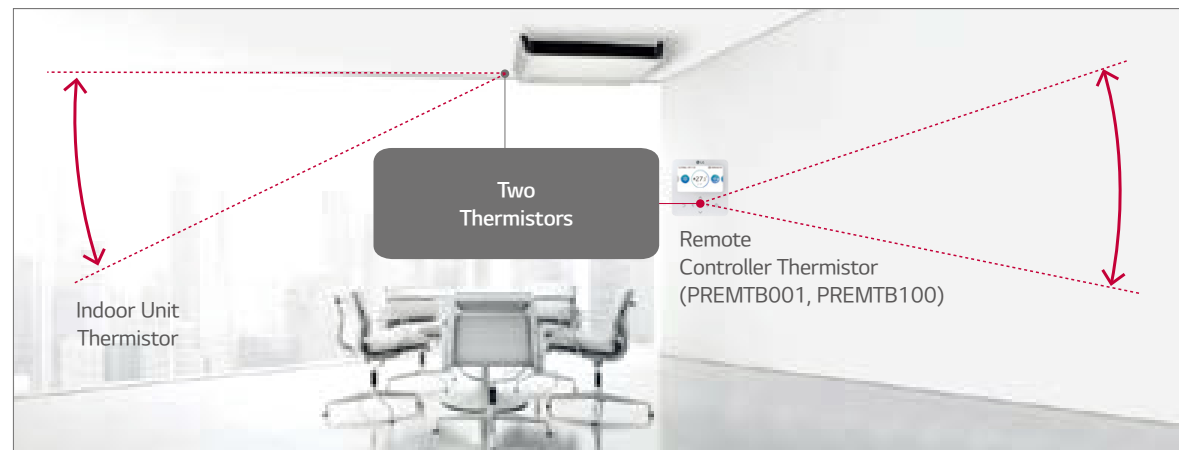

CEILING SUSPENDED UNIT

ARNU18GV1A4 / ARNU24GV1A4
ARNU36GV2A4 / ARNU48GV2A4



Model	Unit	ARNU18GV1A4	ARNU24GV1A4	ARNU36GV2A4	ARNU48GV2A4
Cooling Capacity	kW	5.6	7.1	10.6	14.1
Heating Capacity	kW	6.3	8.0	11.9	15.9
Power Input (H / M / L)	Nominal W	23 / 20 / 17	25 / 21 / 17	84 / 77 / 66	91 / 79 / 66
Exterior Color		Morning Fog	Morning Fog	Morning Fog	Morning Fog
RAL code		RAL 9001	RAL 9001	RAL 9001	RAL 9001
Dimensions (W x H x D)	Body	mm	1,200 x 235 x 690	1,200 x 235 x 690	1,600 x 235 x 690
	Shipping	mm	1,315 x 320 x 772	1,315 x 320 x 772	1,715 x 320 x 772
Fan	Type		Cross Flow Fan	Cross Flow Fan	Cross Flow Fan
	Motor Output x Number	W x No.	85.9 x 1	85.9 x 1	125 x 1
	Air Flow Rate (H / M / L)	m ³ /min	13.5 / 12.5 / 12.0	14.0 / 13.0 / 12.0	27.0 / 24.0 / 20.0
	Motor Type		BLDC	BLDC	BLDC
Air Filter		Pre Filter	Pre Filter	Pre Filter	Pre Filter
Pipe Connections	Liquid Side	mm(inch)	Ø6.35(1/4)	Ø9.52(3/8)	Ø9.52(3/8)
	Gas Side	mm(inch)	Ø12.7(1/2)	Ø15.88(5/8)	Ø15.88(5/8)
	Drain Pipe (Internal Dia.)	mm(inch)	Ø16(5/8)	Ø16(5/8)	Ø16(5/8)
Weight	Body	kg	29.0	29.0	37.0
Sound Pressure Levels (H / M / L)		dB(A)	36 / 34 / 33	37 / 35 / 33	48 / 46 / 44
Sound Power Levels (H / M / L)		dB(A)	61 / 59 / 56	62 / 59 / 56	68 / 66 / 64
Power Supply		Ø, V, Hz	1, 220 - 240, 50	1, 220 - 240, 50	1, 220 - 240, 50
Communication Cable		mm ² x No.	1.0 - 1.5 x 2C	1.0 - 1.5 x 2C	1.0 - 1.5 x 2C

* Nominal : Performance tested under EN14511

* Rated : Max power input allowed for fan motor

Note : 1. Capacities are based on the following conditions

- Cooling : Indoor temp. 27°C (80.6°F) DB / 19°C (66.2°F) WB, Outdoor temp. 35°C (95°F) DB / 24°C (75.2°F) WB, Interconnecting piping length 7.5m, Level difference of zero
- Heating : Indoor temp. 20°C (68°F) DB / 15°C (59°F) WB, Outdoor temp. 7°C (44.6°F) DB / 6°C (42.8°F) WB, Interconnecting piping length 7.5m, Level difference of zero
- 2. Due to our policy of innovation some specifications may be changed without notification
- 3. I.D : 'Internal Diameter'

Accessories

Chassis	ARNU18GV1A4	ARNU24GV1A4	ARNU36GV2A4	ARNU48GV2A4
Drain Pump			-	-
Cassette Cover			-	-
Refrigerant Leakage Detector			PRLDNVSO	
EEV Kit			-	-
Independent Power Module			PRIP0	
Robot Cleaner			-	-
Pre Filter (washable / anti-fungus)			○	
Ion Generator			-	-
CO ₂ Sensor			-	-
Ventilation Kit			-	-
IR Receiver			-	-
Zone Controller			-	-
Dry Contact (with additional accessory)			PDRYCB000 (1 point contact) PDRYCB300 (8 points for thermostat compatible) PDRYCB400 (2 points input) PDRYCB500 (Modbus)	
External Input (1 point)			○	
Wi-Fi			PWFMDD200	

※ ○ : Applied, - : Not applied

Option : Refer to model name in table

CEILING & FLOOR CONVERTIBLE UNIT

ARNU09GVEA4 / ARNU12GVEA4



Model	Unit	ARNU09GVEA4	ARNU12GVEA4
Cooling Capacity	kW	2.8	3.6
Heating Capacity	kW	3.2	4.0
Power Input (H / M / L)	Nominal W	19 / 15 / 11	28 / 19 / 15
Exterior Color		Morning Fog	Morning Fog
RAL code		RAL 9001	RAL 9001
Dimensions (W x H x D)	Body	mm	900 x 490 x 200
	Shipping	mm	975 x 279 x 562
Fan	Type		Cross Flow Fan
	Motor Output x Number	W x No.	27 x 1
	Air Flow Rate (H / M / L)	m ³ /min	7.6 / 6.9 / 6.2
		cfm	268 / 244 / 219
Motor Type		BLDC	
Air Filter		Pre Filter	Pre Filter
Pipe Connections	Liquid Side	mm(inch)	Ø6.35 (1/4)
	Gas Side	mm(inch)	Ø12.7 (1/2)
	Drain Pipe (Internal Dia.)	mm(inch)	Ø16 (5/8)
Weight	Body	kg	13.3
Sound Pressure Levels (H / M / L)		dB(A)	36 / 32 / 28
Sound Power Levels (H / M / L)		dB(A)	55 / 51 / 45
Power Supply		Ø, V, Hz	1, 220-240, 50
Communication Cable		mm ² x No.	1.0 - 1.5 x 2C

* Nominal : Performance tested under EN14511

* Rated : Max power input allowed for fan motor

Note : 1. Capacities are based on the following conditions

- Cooling : Indoor temp. 27°C (80.6°F) DB / 19°C (66.2°F) WB, Outdoor temp. 35°C (95°F) DB / 24°C (75.2°F) WB, Interconnecting piping length 7.5m, Level difference of zero
- Heating : Indoor temp. 20°C (68°F) DB / 15°C (59°F) WB, Outdoor temp. 7°C (44.6°F) DB / 6°C (42.8°F) WB, Interconnecting piping length 7.5m, Level difference of zero
- 2. Due to our policy of innovation some specifications may be changed without notification
- 3. I.D : 'Internal Diameter'

Accessories

Chassis	ARNU09GVEA4	ARNU12GVEA4
Drain Pump		-
Cassette Cover		-
Refrigerant Leakage Detector		PRLDNVSO
EEV Kit		PRGK024A0
Independent Power Module		PRIP0
Robot Cleaner		-
Pre Filter (washable / anti-fungus)		○
Ion Generator		-
CO ₂ Sensor		-
Ventilation Kit		-
IR Receiver		-
Zone Controller		-
Dry Contact (with additional accessory)		PDRYCB000 (1 point contact) PDRYCB300 (8 points for thermostat compatible) PDRYCB400 (2 points input) PDRYCB500 (Modbus)
External Input (1 point)		○
Wi-Fi		PWFMDD200 ¹⁾

※ ○ : Applied, - : Not applied

Option : Refer to model name in table

CONSOLE & FLOOR STANDING UNIT



Features & Benefits

- Ideal for Installation Beneath a Window
- Unit Requires Minimal Installation Space
- Fitted with a Washable Long-life Filter

Key Applications

- School
- Office
- Church
- Historic Building

	Floor standing	Console	Floor Standing Unit
Smart	Wi-Fi	○	○
Energy Efficiency	Jet Cool	-	○
Health	Ionizer	○	-
Fast Cooling & Heating	Jet Cool	○	-
Comfort	Sleep Mode	○	○
	Timer (on / off)	○	○
	Timer (weekly)	○	○
	Two Thermistor Control	○	○
	Group Control	○	○

※ ○ : Applied, - : Not applied

Wi-Fi Control

Control your air conditioners via using the smart internet devices as Android or iOS based smartphones. This advanced technology provides you the best convenience.

LG SmartThinQ

 Search "LG SmartThinQ" on Google market or Appstore then download the app.
LG SmartThinQ

Access your air conditioner anytime and from anywhere

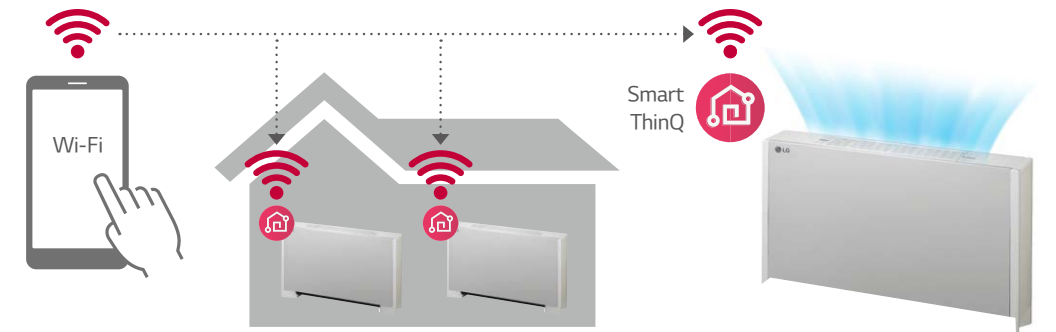

Installation Support Clip

During the cooling operation, the vane adjusts upwards to direct the air flow towards the ceiling. When heating, the vane directs the warm air downwards to balance the room temperature especially for floor.

Cooling

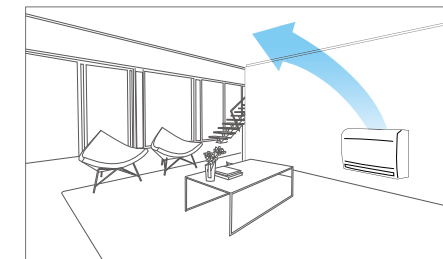

Heating (Normal)

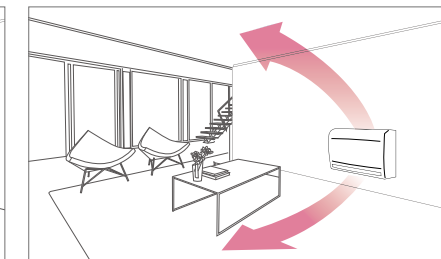

Heating (Option)

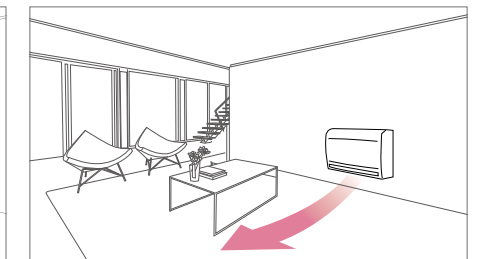

Block Cold Draft

The console can block cold drafts from windows to provide a warmer environment for places such as libraries and offices.

Without Console

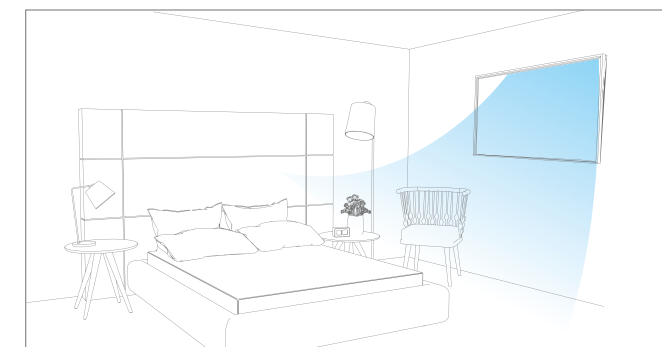

With Console

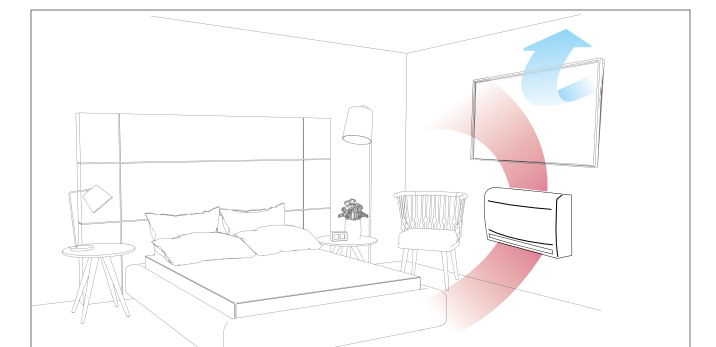

CONSOLE & FLOOR STANDING UNIT

5-Step Vane Control

There are 5 different stages to control air flow direction.

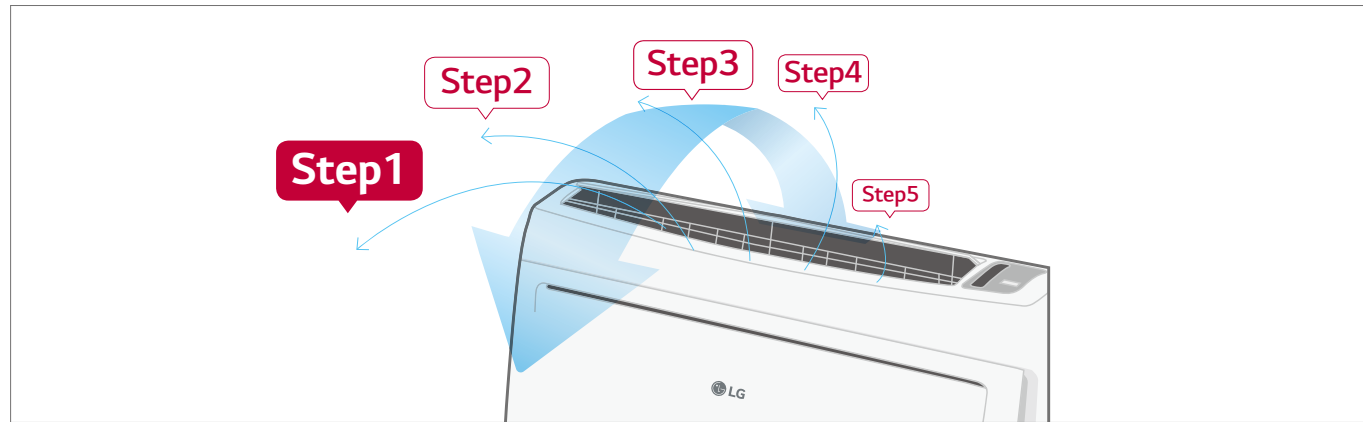

3 Way Flexible Installation

It is possible to install and connect the outdoor unit in 6 different ways. (Right Side, Right Back, Right Floor, Left Side, Left Back, Left Floor)

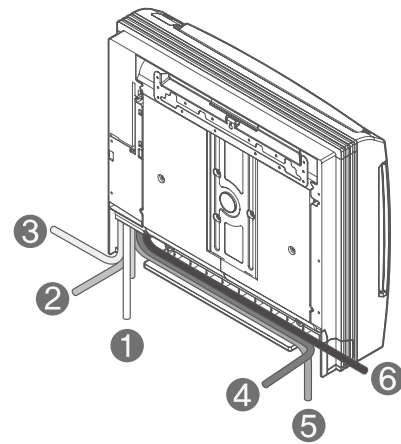

Block Cold Draft

The floor standing unit can block cold drafts from windows to provide a warmer environment for places such as libraries and offices.

Without Floor Standing

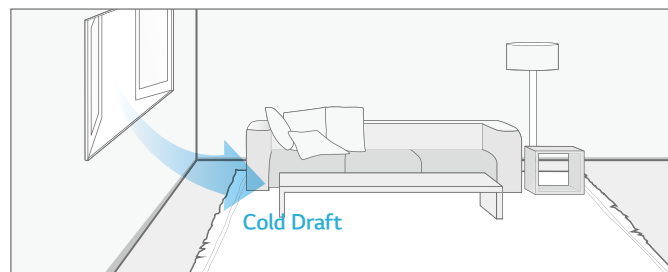

With Floor Standing

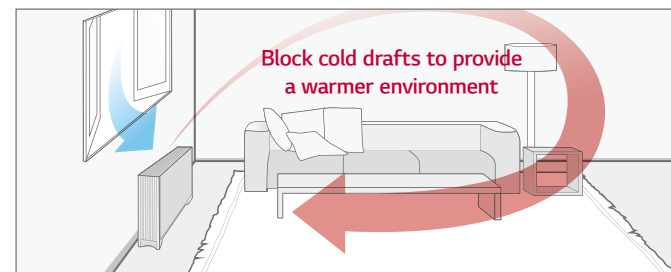

3 Way Flexible Installation

It is possible to install and connect the outdoor unit in 3 different ways (Side, Back, Floor).

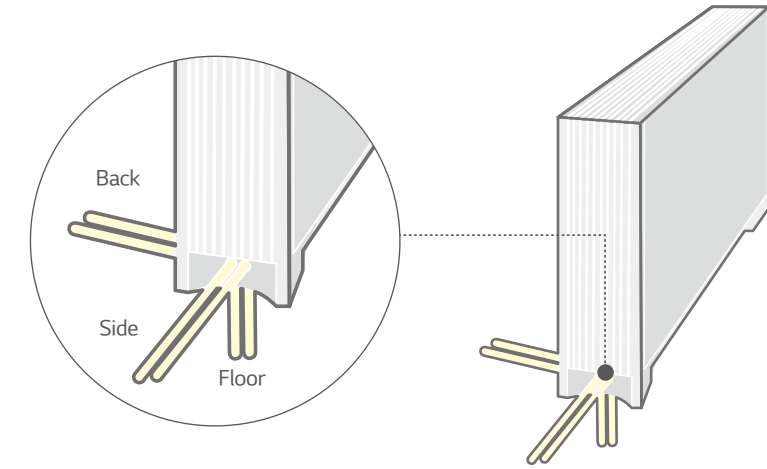

Sliding Type Filter

Easy maintenance and extended product life with sliding type filter.

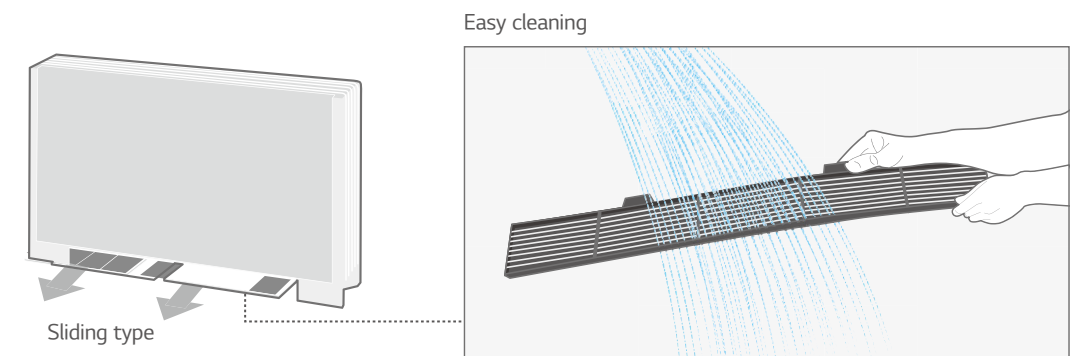

CONSOLE

ARNU07GQAA4 / ARNU09GQAA4



Model	Unit	ARNU07GQAA4	ARNU09GQAA4
Cooling Capacity	kW	2.2	2.8
Heating Capacity	kW	2.5	3.2
Power Input (H / M / L)	Nominal W	15 / 12 / 10	15 / 12 / 10
Exterior Color		Morning Fog	Morning Fog
RAL Code		RAL 9001	RAL 9001
Dimensions (W x H x D)	Body mm	700 x 600 x 210	700 x 600 x 210
	Shipping mm	775 x 662 x 284	775 x 662 x 284
Fan	Type	Turbo fan	Turbo fan
	Motor Output x Number	W x No.	48 x 1
	Air Flow Rate (H / M / L)	m ³ /min	6.7 / 5.9 / 4.8
	Motor Type		BLDC
Air Filter		Pre Filter	Pre Filter
Pipe Connections	Liquid Side mm (inch)	Ø6.35(1/4)	Ø6.35(1/4)
	Gas Side mm (inch)	Ø12.7(1/2)	Ø12.7(1/2)
	Drain Pipe (Internal Dia.) mm (inch)	Ø12(15/32)	Ø12(15/32)
Weight	Body kg	14.0	14.0
Sound Pressure Levels (H / M / L)	dB (A)	37 / 34 / 28	37 / 34 / 28
Sound Power Levels (H / M / L)	dB (A)	53 / 50 / 44	53 / 50 / 44
Power Supply	Ø, V, Hz	1, 220-240, 50	1, 220-240, 50
		1, 220, 60	1, 220, 60
Communication Cable	mm ² x No.	1.0-1.5 x 2C	1.0-1.5 x 2C

* Nominal : Performance tested under EN14511

* Rated : Max power input allowed for fan motor

Note : 1. Capacities are based on the following conditions

- Cooling : Indoor temp. 27°C (80.6°F) DB / 19°C (66.2°F) WB, Outdoor temp. 35°C (95°F) DB / 24°C (75.2°F) WB, Interconnecting piping length 7.5m, Level difference of zero
- Heating : Indoor temp. 20°C (68°F) DB / 15°C (59°F) WB, Outdoor temp. 7°C (44.6°F) DB / 6°C (42.8°F) WB, Interconnecting piping length 7.5m, Level difference of zero
- 2. Due to our policy of innovation some specifications may be changed without notification
- 3. I.D : 'Internal Diameter'

Accessories

Chassis	ARNU07GQAA4	ARNU15GQAA4
Drain Pump		-
Cassette Cover		-
Refrigerant Leakage Detector		PRLDNVSO
EEV Kit		PRGK024A0
Independent Power Module		PRIP0
Robot Cleaner		-
Pre Filter (washable / anti-fungus)		○
Ion Generator		○
CO ₂ Sensor		-
Ventilation Kit		-
IR Receiver		-
Zone Controller		-
Dry Contact (with additional accessory)		PDRYCB000 (1 point contact) PDRYCB300 (8 points for thermostat compatible) PDRYCB400 (2 points input) PDRYCB500 (Modbus)
External Input (1 point)		○
Wi-Fi		PWFMD200

※ ○ : Applied, - : Not applied
Option : Refer to model name in table

ARNU12GQAA4 / ARNU15GQAA4



Model	Unit	ARNU12GQAA4	ARNU15GQAA4
Cooling Capacity	kW	3.6	4.5
Heating Capacity	kW	4.0	5.0
Power Input (H / M / L)	Nominal W	18 / 15 / 13	24 / 19 / 17
Exterior Color		Morning Fog	Morning Fog
RAL Code		RAL 9001	RAL 9001
Dimensions (W x H x D)	Body mm	700 x 600 x 210	700 x 600 x 210
	Shipping mm	775 x 662 x 284	775 x 662 x 284
Fan	Type	Turbo fan	Turbo fan
	Motor Output x Number	W x No.	48 x 1
	Air Flow Rate (H / M / L)	m ³ /min	7.5 / 5.9 / 4.8
	Motor Type		BLDC
Air Filter		Pre Filter	Pre Filter
Pipe Connections	Liquid Side mm (inch)	Ø6.35(1/4)	Ø6.35(1/4)
	Gas Side mm (inch)	Ø12.7(1/2)	Ø12.7(1/2)
	Drain Pipe (Internal Dia.) mm (inch)	Ø12(15/32)	Ø12(15/32)
Weight	Body kg	14.0	14.0
Sound Pressure Levels (H / M / L)	dB (A)	39 / 34 / 28	42 / 37 / 31
Sound Power Levels (H / M / L)	dB (A)	56 / 50 / 44	58 / 53 / 50
Power Supply	Ø, V, Hz	1, 220-240, 50	1, 220-240, 50
		1, 220, 60	1, 220, 60
Communication Cable	mm ² x No.	1.0-1.5 x 2C	1.0-1.5 x 2C

* Nominal : Performance tested under EN14511

* Rated : Max power input allowed for fan motor

Note : 1. Capacities are based on the following conditions

- Cooling : Indoor temp. 27°C (80.6°F) DB / 19°C (66.2°F) WB, Outdoor temp. 35°C (95°F) DB / 24°C (75.2°F) WB, Interconnecting piping length 7.5m, Level difference of zero
- Heating : Indoor temp. 20°C (68°F) DB / 15°C (59°F) WB, Outdoor temp. 7°C (44.6°F) DB / 6°C (42.8°F) WB, Interconnecting piping length 7.5m, Level difference of zero
- 2. Due to our policy of innovation some specifications may be changed without notification
- 3. I.D : 'Internal Diameter'

Accessories

Chassis	ARNU12GQAA4	ARNU15GQAA4
Drain Pump		-
Cassette Cover		-
Refrigerant Leakage Detector		PRLDNVSO
EEV Kit		PRGK024A0
Independent Power Module		PRIP0
Robot Cleaner		-
Pre Filter (washable / anti-fungus)		○
Ion Generator		○
CO ₂ Sensor		-
Ventilation Kit		-
IR Receiver		-
Zone Controller		-
Dry Contact (with additional accessory)		PDRYCB000 (1 point contact) PDRYCB300 (8 points for thermostat compatible) PDRYCB400 (2 points input) PDRYCB500 (Modbus)
External Input (1 point)		○
Wi-Fi		PWFMD200

※ ○ : Applied, - : Not applied
Option : Refer to model name in table

FLOOR STANDING UNIT

ARNU07GCEA4 / ARNU09GCEA4 / ARNU12GCEA4
ARNU15GCEA4 / ARNU18GCF4A / ARNU24GCF4A



* A : Floor Standing with case

Model	Unit	ARNU07GCEA4	ARNU09GCEA4	ARNU12GCEA4	ARNU15GCEA4	ARNU18GCF4A	ARNU24GCF4A
Cooling Capacity	kW	2.2	2.8	3.6	4.5	5.6	7.1
Heating Capacity	kW	2.5	3.2	4.0	5.0	6.3	8.0
Power Input (H / M / L)	Nominal W	24 / 17 / 14	30 / 24 / 17	36 / 30 / 24	44 / 35 / 28	54 / 41 / 29	84 / 54 / 41
Exterior Color		Morning Fog	Morning Fog	Morning Fog	Morning Fog	Morning Fog	Morning Fog
RAL Code		RAL 9001	RAL 9001	RAL 9001	RAL 9001	RAL 9001	RAL 9001
Dimensions (W x H x D)	Body	mm	1,067 x 635 x 203	1,067 x 635 x 203	1,067 x 635 x 203	1,345 x 635 x 203	1,345 x 635 x 203
	Shipping	mm	1,154 x 705 x 289	1,154 x 705 x 289	1,154 x 705 x 289	1,432 x 705 x 289	1,432 x 705 x 289
Fan	Type		Sirocco Fan	Sirocco Fan	Sirocco Fan	Sirocco Fan	Sirocco Fan
	Motor Output x Number	W x No.	19 x 1, 5 x 1	19 x 1, 5 x 1	19 x 1, 5 x 1	19 x 1, 5 x 1	19 x 2
	Air Flow Rate (H / M / L)	m ³ /min	8.5 / 7.5 / 6.5	9.5 / 8.5 / 7.5	10.5 / 9.5 / 8.5	11.5 / 10.0 / 9.5	16.0 / 14.0 / 12.0
	Motor Type		BLDC	BLDC	BLDC	BLDC	BLDC
Air Filter		Pre Filter	Pre Filter	Pre Filter	Pre Filter	Pre Filter	Pre Filter
Pipe Connections	Liquid Side	mm (inch)	Ø6.35(1/4)	Ø6.35(1/4)	Ø6.35(1/4)	Ø6.35(1/4)	Ø9.52(3/8)
	Gas Side	mm (inch)	Ø12.7(1/2)	Ø12.7(1/2)	Ø12.7(1/2)	Ø12.7(1/2)	Ø15.88(5/8)
	Drain Pipe(Internal Dia.)	mm (inch)	Ø12(15/32)	Ø12(15/32)	Ø12(15/32)	Ø12(15/32)	Ø12(15/32)
Weight	Body	kg	27.0	27.0	27.0	34.0	34.0
Sound Pressure Levels (H / M / L)		dB (A)	35 / 33 / 31	36 / 34 / 32	37 / 35 / 33	38 / 37 / 35	40 / 37 / 34
Sound Power Levels (H / M / L)		dB (A)	52 / 47 / 43	54 / 51 / 47	54 / 51 / 50	55 / 54 / 51	57 / 54 / 50
Power Supply		Ø, V, Hz	1, 220-240, 50	1, 220-240, 50	1, 220-240, 50	1, 220-240, 50	1, 220-240, 50
Communication Cable		mm ² x No.	1.0-1.5 x 2C	1.0-1.5 x 2C	1.0-1.5 x 2C	1.0-1.5 x 2C	1.0-1.5 x 2C

* Nominal : Performance tested under EN14511

* Rated : Max power input allowed for fan motor

Note : 1. Capacities are based on the following conditions

- Cooling : Indoor temp. 27°C (80.6°F) DB / 19°C (66.2°F) WB, Outdoor temp. 35°C (95°F) DB / 24°C (75.2°F) WB, Interconnecting piping length 7.5m, Level difference of zero
- Heating : Indoor temp. 20°C (68°F) DB / 15°C (59°F) WB, Outdoor temp. 7°C (44.6°F) DB / 6°C (42.8°F) WB, Interconnecting piping length 7.5m, Level difference of zero

2. Due to our policy of innovation some specifications may be changed without notification

3. I.D : 'Internal Diameter'

Accessories

Chassis	ARNU07GCEA4	ARNU09GCEA4	ARNU12GCEA4	ARNU15GCEA4	ARNU18GCF4A	ARNU24GCF4A
Drain Pump		-			-	
Cassette Cover		-			-	
Refrigerant Leakage Detector		PRLDNVSO			PRLDNVSO	
EEV Kit		PRGK024A0			-	
Independent Power Module		PRIPO			PRIPO	
Robot Cleaner		-			-	
Pre Filter (washable / anti-fungus)		○			○	
Ion Generator		-			-	
CO ₂ Sensor		-			-	
Ventilation Kit		-			-	
IR Receiver		PWLRVN000			PWLRVN000	
Zone Controller		-			-	
Dry Contact (with additional accessory)		PDRYCB000 (1 point contact) PDRYCB300 (8 points for thermostat compatible) PDRYCB400 (2 points input) PDRYCB500 (Modbus)			PDRYCB000 (1 point contact) PDRYCB300 (8 points for thermostat compatible) PDRYCB400 (2 points input) PDRYCB500 (Modbus)	
External Input (1 point)		○			○	
Wi-Fi		PWFMD200			PWFMD200	

※ ○ : Applied, - : Not applied

Option : Refer to model name in table

ARNU07GCEU4 / ARNU09GCEU4 / ARNU12GCEU4
ARNU15GCEU4 / ARNU18GCFU4 / ARNU24GCFU4



* U : Floor Standing without case

Model	Unit	ARNU07GCEU4	ARNU09GCEU4	ARNU12GCEU4	ARNU15GCEU4	ARNU18GCFU4	ARNU24GCFU4
Cooling Capacity	kW	2.2	2.8	3.6	4.5	5.6	7.1
Heating Capacity	kW	2.5	3.2	4.0	5.0	6.3	8.0
Power Input (H / M / L)	Nominal W	24 / 17 / 14	30 / 24 / 17	36 / 30 / 24	44 / 35 / 28	54 / 41 / 29	84 / 54 / 41
Dimensions (W x H x D)	Body	mm	978 x 639 x 190	978 x 639 x 190	978 x 639 x 190	978 x 639 x 190	1,256 x 639 x 190
	Shipping	mm	1,055 x 702 x 260	1,055 x 702 x 260	1,055 x 702 x 260	1,055 x 702 x 260	1,333 x 702 x 260
Fan	Type		Sirocco Fan	Sirocco Fan	Sirocco Fan	Sirocco Fan	Sirocco Fan
	Motor Output x Number	W x No.	19 x 1, 5 x 1	19 x 1, 5 x 1	19 x 1, 5 x 1	19 x 1, 5 x 1	19 x 2
	Air Flow Rate (H / M / L)	m ³ /min	8.5 / 7.5 / 6.5	9.5 / 8.5 / 7.5	10.5 / 9.5 / 8.5	11.5 / 10.0 / 9.5	16.0 / 14.0 / 12.0
	Motor Type		BLDC	BLDC	BLDC	BLDC	BLDC
Air Filter		Pre Filter	Pre Filter	Pre Filter	Pre Filter	Pre Filter	Pre Filter
Pipe Connections	Liquid Side	mm (inch)	Ø6.35(1/4)	Ø6.35(1/4)	Ø6.35(1/4)	Ø6.35(1/4)	Ø9.52(3/8)
	Gas Side	mm (inch)	Ø12.7(1/2)	Ø12.7(1/2)	Ø12.7(1/2)	Ø12.7(1/2)	Ø15.88(5/8)
	Drain Pipe(Internal Dia.)	mm (inch)	Ø12(15/32)	Ø12(15/32)	Ø12(15/32)	Ø12(15/32)	Ø12(15/32)
Weight	Body	kg	20.0	20.0	20.0	26.0	26.0
Sound Pressure Levels (H / M / L)		dB (A)	35 / 33 / 31	36 / 34 / 32	37 / 35 / 33	38 / 37 / 35	40 / 37 / 34
Sound Power Levels (H / M / L)		dB (A)	52 / 47 / 43	54 / 51 / 47	54 / 51 / 50	55 / 54 / 51	57 / 54 / 50
Power Supply		Ø, V, Hz	1, 220-240, 50	1, 220-240, 50	1, 220-240, 50	1, 220-240, 50	1, 220-240, 50
Communication Cable		mm ² x No.	1.0-1.5 x 2C	1.0-1.5 x 2C	1.0-1.5 x 2C	1.0-1.5 x 2C	1.0-1.5 x 2C

* Nominal : Performance tested under EN14511

* Rated : Max power input allowed for fan motor

Note : 1. Capacities are based on the following conditions

- Cooling : Indoor temp. 27°C (80.6°F) DB / 19°C (66.2°F) WB, Outdoor temp. 35°C (95°F) DB / 24°C (75.2°F) WB, Interconnecting piping length 7.5m, Level difference of zero
- Heating : Indoor temp. 20°C (68°F) DB / 15°C (59°F) WB, Outdoor temp. 7°C (44.6°F) DB / 6°C (42.8°F) WB, Interconnecting piping length 7.5m, Level difference of zero

2. Due to our policy of innovation some specifications may be changed without notification

3. I.D : 'Internal Diameter'

Accessories

Chassis	ARNU07GCEU4	ARNU09GCEU4	ARNU12GCEU4	ARNU15GCEU4	ARNU18GCFU4	ARNU24GCFU4
Drain Pump		-			-	
Cassette Cover		-			-	
Refrigerant Leakage Detector		PRLDNVSO			PRLDNVSO	
EEV Kit		PRGK024A0			-	
Independent Power Module		PRIPO			PRIPO	
Robot Cleaner		-			-	
Pre Filter (washable / anti-fungus)		○			○	
Ion Generator		-			-	
CO ₂ Sensor		-			-	
Ventilation Kit		-			-	
IR Receiver		PWLRVN000			PWLRVN000	
Zone Controller		-			-	
Dry Contact (with additional accessory)		PDRYCB000 (1 point contact) PDRYCB300 (8 points for thermostat compatible) PDRYCB400 (2 points input) PDRYCB500 (Modbus)			PDRYCB000 (1 point contact) PDRYCB300 (8 points for thermostat compatible) PDRYCB400 (2 points input) PDRYCB500 (Modbus)	
External Input (1 point)		○			○	
Wi-Fi		PWFMD200			PWFMD200	

※ ○ : Applied, - : Not applied

Option : Refer to model name in table

COMPATIBILITY

No.	New Function Name (4 th generation indoor)	Function Description	Required Controller		Remarks
			Wired Remote Controller	Centralized Controller	
1	Energy Monitoring (Accumulated Electric Energy Check)	Monitoring accumulated power consumption by Wired Remote Controller	○	○	* Necessary to install the PDI (Power Distribution Indicator) and central controller * Combined with MULTI V Water S outdoor unit, this function is not available.
		Monitoring accumulated power consumption by Central Control Device / PDI	-	○	* Necessary to install the PDI (Power Distribution Indicator) * To make a report, central controller must be installed
2	2 Set Point	1) 2 set point control by Indoor and Central controller 2) Synchronization function with remote control (Synchronization Setting and Monitoring)	○	○	* Wired remote controller and central controller must be installed * Combined with MULTI V Water S outdoor unit, this function is not available.
3	Occupied / Unoccupied Scheduling Function (Sub Func. Enable)	1) Synchronization according to occupied/unoccupied by Indoor and Central control 2) Synchronization icon with remote controller (Synchronization Monitoring)	○	○	* Centralized control is able to when you combine only 4 th generation indoor units (Use together with 2 nd generation and 4 th generation indoors, only wired remote controller is able to set this function as existing way) * Wired remote controller or central controller must be installed (Function can be activated using just one control device.) * Combined with MULTI V Water S outdoor unit, this function is not available.
4	Group Control	Group Control can use Additional function	○	○	* Check more details in PDB (Product Data Book) * Central controller can create and control group.
5	Test Run (Heating)	Test run mode can be operated in cooling mode and heating mode for easy service	○	-	
6	Model Information Monitoring	Product Type / Indoor Type / Indoor capacity information can be monitored by remote controller	○	-	
7	Indoor unit address checking	Wired remote controller can check indoor unit address information	○	-	
8	Refrigerant Leakage Detection	Function error sign display when refrigerant leakage occurred	○	○	* Central controller has been installed, CH230 error code can be recognized (Old/New Same) * Without Central Controller, it is able to recognize with wired remote controller (CH230) * Combined with MULTI V Water S outdoor unit, this function is not available. * Accessory PRLDNV50 must be separately ordered
9	Thermo On / Off range Setting (Cooling)	User can set cooling thermo on/off range with wired remote controller for prevention overcooling	○	-	* Thermo On / Off temperature setting (3 step)
10	Thermo On / Off range Setting (Heating)	User can set heating thermo on/off range with wired remote controller for prevention overheating. (4 Steps)	○	-	* Thermo On / Off temperature setting (4 step)
11	Static Pressure 11 Step Control (Only for Ceiling Concealed Duct Type)	Depends on the installation environment, 4 th generation Ceiling Concealed Duct can control the static pressure by 11 steps for providing comfortable environment	○	-	* Only applied in Ceiling Concealed Duct
12	1 point External Input (On / Off control)	Indoor unit can control external devices without purchasing Dry contact as an accessory (All 4 th generation indoors)	○	-	* Simple On/Off control by Dry Contact at Indoor [Example of Contact port by product type] * 2 Way Cassette : CN-CC Port (Wired remote controller installation function mode 41 is required) * 1 Way / 4 Way Cassette / Ceiling Concealed Duct / Wall Mounted Unit Console / FAU / Floor Standing (with case / without case) : CN-EXT Port
13	Filter Sign (Remaining Time)	The alarm activates when the filter needs to be cleaned, and the time remaining for cleaning is displayed on the screen.	○	○	* The alarm activates on the central controller, but the remaining time is not displayed.
14	Auto restart function Disable / Enable	After the power failure compensation, stand by at OFF mode Restore the operation for the status before the power off	○	-	
15	Indoor Humidity display	Monitoring indoor humidity Wired Remote Controller	○	○	* Available only with MULTI V 5
16	Comfort Cooling setting	set the outdoor unit Comfort cooling operation value	○	○	* Available only with MULTI V 5
17	Smart Load Control setting	Change the outdoor unit's Smart Load Control stage value.	○	○	* Available only with MULTI V 5
18	ODU Refrigerant Noise Reduction setting	set the outdoor unit's refrigerant noise reduction function	○	○	* Available only with MULTI V 5
19	Low noise mode time setting	set the start and end time of the outdoor unit's low noise mode operation	○	○	* Available only with MULTI V 5

Note : 1. No.1, 2, 3, 8 : Functions are available to use together with 4th generation Indoor units only. If used together 2nd generation indoor unit and 4th generation indoor unit functions will not be activate. Combined with MULTI V Water S outdoor unit this function is not available
2. No. 4, 5, 6, 7, 9, 10, 11, 12, 13, 14 : If used together 2nd generation indoor unit and 4th generation indoor unit these functions will be activate only in 4th generation indoor
3. 2nd generation indoor unit : Ceiling & Floor Convertible Unit, Ceiling Suspended Unit, HYDRO KIT (Low Temp. / High Temp.), ERV DX (with Humidifier, without Humidifier), AHU Communication Kit

	Wired Remote Controller					Centralized Controller				
	Premium (PREMTA000 PREMTA000A PREMTA000B)	Standard III (PREMTB100) (PREMTBB10)	Standard II (PREMTBB01) (PREMTB001)	Simple		AC EZ (PQCSZ250S0)	AC EZ Touch (PACEZA000)	AC Smart 5 (PACS5A000)	ACP 5 (PACP5A000)	AC Manager 5 (PACM5A000)
				Simple for Hotel (PORCHCA00/QW)	Simple (PORCVL00/QW)					
○	○	○	-	-	-	○	○	○	○	
-	-	-	-	-	-	○	○	○	○	
○	○	-	-	-	-	○	○	○	○	
○	○	-	-	-	-	○	○	○	○	
○	○	○	-	-	-	-	○	○	○	
○	○	○	-	-	-	-	-	-	-	
○	○	○	-	-	-	-	-	-	-	
○	○	○	-	-	-	-	○	○	-	
○	○	○	-	-	-	-	-	-	-	
○ (4 step)	○ (4 step)	○ (3 step)	○ (3 step)	○ (3 step)	-	-	-	-	-	
○	○	○	○	○	-	-	-	-	-	
-	○	○	-	-	-	-	-	-	-	
○	○	○	-	-	○	○	○	○	○	
○	○	○	-	-	-	-	-	-	-	
-	○	-	-	-	-	-	○	○	-	
-	○	-	-	-	-	-	○	○	-	
-	○	-	-	-	-	-	○	○	-	
-	○	-	-	-	-	○	○	○	-	

※ ○ : Applied, - : Not applied

COMPATIBILITY

Controller	Premium		Standard III		Standard II		Simple		Simple for Hotel		Wireless	Dry Contact			
	PREMTA000 PREMTA000A PREMTA000B	PREMTB10	PREMTB100	PREMTB801	PREMTB001	PQRCVCLQ	PQRCVCOQW	PQRCHCAQ	PQRCHCAQW	PQWRHQFDB	Simple Dry Contact PDRYCB00	2 points Dry Contact PDRYCB400	Dry Contact for Thermostat PDRYCB300	For Modbus PDRYCB500	
Round Cassette	ARNU24GYA4	○	○	○	○	○	○	○	○	○	○	○	○		
	ARNU36GYA4	○	○	○	○	○	○	○	○	○	○	○	○		
	ARNU48GYA4	○	○	○	○	○	○	○	○	○	○	○	○		
Ceiling Mounted Cassette	ARNU-A4	○	○	○	○	○	○	○	○	○	○	○	○		
	ARNU-D4	○	○	○	○	○	○	○	○	○	○	○	○		
4 Way	ARNU-C4	○	○	○	○	○	○	○	○	○	○	○	○		
2 Way / 1 Way	ARNU-A4	○	○	○	○	○	○	○	△	○	○	○	○		
Ceiling Concealed Duct	High Sensible	ARNU-A4	○	○	○	○	○	○	△	○	○	○	○		
	High / Mid Statics	ARNU-A4	○	○	○	○	○	○	△	○	○	○	○		
	Low Statics	ARNU-G4	○	○	○	○	○	○	△	○	○	○	○		
FAU (Fresh Air Intake Unit)	ARNU-Z4	○	○	○	○	○	○	○	△	○	○	○	○		
Convertible & Ceiling Suspended Unit	ARNU-A4	○	○	○	○	○	○	○	○	○	○	○	○		
Console	ARNU-A4	○	○	○	○	○	○	○	○	○	○	○	○		
Floor Standing Unit	ARNU-A4	○	○	○	○	○	○	○	○	○	○	○	○		
	ARNU-U4	○	○	○	○	○	○	○	○	○	○	○	○		
Wall Mounted Unit	ARNU-A4	○	○	○	○	○	○	○	○	○	○	○	○		
HYDRO KIT 1)	ARNU-A4	○	○	○	○	○	○	○	○	○	○	○	○		
	ARNU-C4	○	○	○	○	○	○	○	○	○	○	○	○		
	ARNU-N4	○	○	○	○	○	○	○	○	○	○	○	○		
Ventilation	Energy Recovery Ventilator	○	○	○	-	-	-	-	-	○	-	-	○		
	Energy Recovery Ventilator with DX coil	○	○	○	-	-	-	-	-	○	-	-	○		
AHU Communication Kit	○	○	○	○	-	-	-	△	-	-	-	-			

※ ○: Compatible, △: Need wired remote controller / IR receiver, - : Not compatible
1) It has a separate remote controller

FEATURE FUNCTIONS

Controller Name	Wired Remote Controller					Wireless Remote Controller	Wi-fi Controller
	Premium	Standard III	Standard II	Simple	Simple(Hotel)		
Model Name							
Model Name	PREMTA000 PREMTA000A PREMTA000B	PREMTB100 PREMTB100	PREMTB001 PREMTB001	PQRCVCLQ PQRCVCOQW	PQRCHCAQ PQRCHCAQW	PQWRHQFDB	PWFMD200
Basic	○	○	○	○	○	○	○
On / Off	○	○	○	○	○	○	○
Fan Speed Control	○	○	○	○	○	○	○
Temperature Setting	○	○	○	○	○	○	○
Mode Change	○	○	○	○	-	○	○
Auto Swing	○	○	○	○	○	○	○
Vane Control (Louver Angle)	○	○	○	○	○	○	○
E.S.P (External Static Pressure)	○	○	○	○	○	-	-
Electric Failure Compensation	○	○	○	○	○	-	○
Indoor Temperature Display	○	○	○	○	○	○	○
ALL Button Lock (Child Lock)	○	○	○	○	○	-	-
Advanced	Weekly-Yearly	Weekly-Yearly	Weekly	-	-	Sleep / On / Off	Weekly
Schedule / Timer	○	○	○	-	-	-	-
Additional Mode Setting 1)	○	○	○	-	-	○	-
Time Display	○	○	○	-	-	-	-
Humid. Display	○	○	-	-	-	-	-
Advanced Lock (mode, set point, set point range, on/off Lock)	Advanced Lock	Advanced Lock	Mode Lock	-	-	-	-
Filter Sign	○	○	○	-	-	-	-
Energy Management 2)	○	○	○	-	-	-	-
Dual Set Point	○	○	-	-	-	-	-
Human Detection	-	○	-	-	-	-	-
Temp, Humidity Compensation	○	○	-	-	-	-	-
Wifi AP mode setting	○	○	○	○	○	○	-
ETC	○	○	○	○	○	-	-
Operation Status LED	○ ³⁾	-	○ ³⁾	○ ³⁾	○ ³⁾	-	-
Wireless Remote Controller Receiver	○ ³⁾	-	○ ³⁾	○ ³⁾	○ ³⁾	-	-
Display	5 inch Color	4.3 inch Color	4.3 inch mono	2.6 inch mono	2.6 inch mono	2 inch mono	-
Size (W x H x D, mm)	137 x 121 x 16.5	120 x 120 x 16	120 x 120 x 16	64 x 120 x 15	64 x 120 x 15	51 x 153 x 26	-
Black Light Control for Screen Saver	○	○	-	-	-	-	-

※ ○: Applied, - : Not Applied

1) It might not be indicated or operated at the partial product

2) Centralized control (PACEZA000 / PACS5A000 / PACPSA000 / PLNWKB000) and PDI (PQNU1S40 / PPWRDB000) should be installed for this function

3) For ceiling type duct

Note: 1. Indoor unit should have functions requested by the controller

2. If you need more detail, please refer to the manual of product. (<http://partner.lge.com>: Home > Doc.Library > Manual)

HOT WATER SOLUTIONS

—
HYDRO KIT



HYDRO KIT

HYDRO KIT Features

Features & Benefits

- Lower operation cost compared to fossil fuel-based systems such as boilers
- More energy saving through MULTI V Heat Recovery system

Key Applications

- Where hot water is needed such as domestic hot water, in-floor or radiant heat. Where cold water is needed such as fan coil unit and chilled beam.

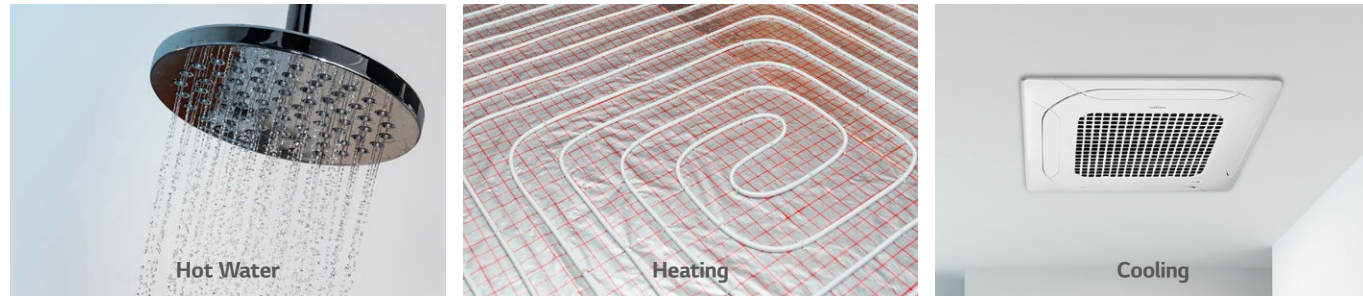

Radiant Heating / Cooling

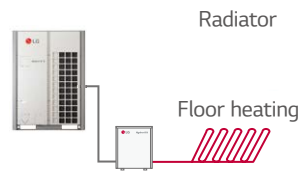

Fan Coil Unit Heating / Cooling

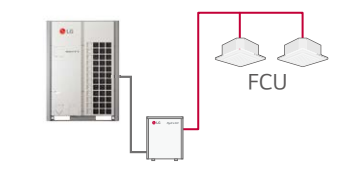

Hot water / Cooled Water

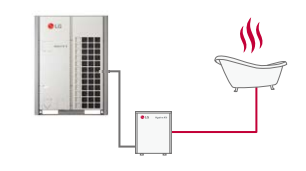

Combination

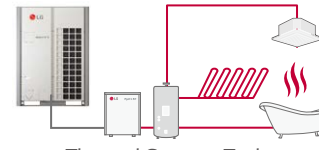
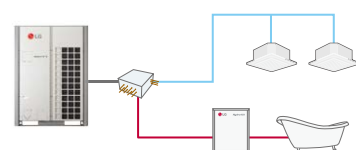

Hot water+ Radiant heating

HR unit (Cooling & Hot water)

Thermal Storage Tank
Thermal Storage System

System Diagram

Providing a total solution by heat pump, air conditioning (cooling by refrigerant & chilled water, heating by refrigerant & hot water) and domestic hot water supply.

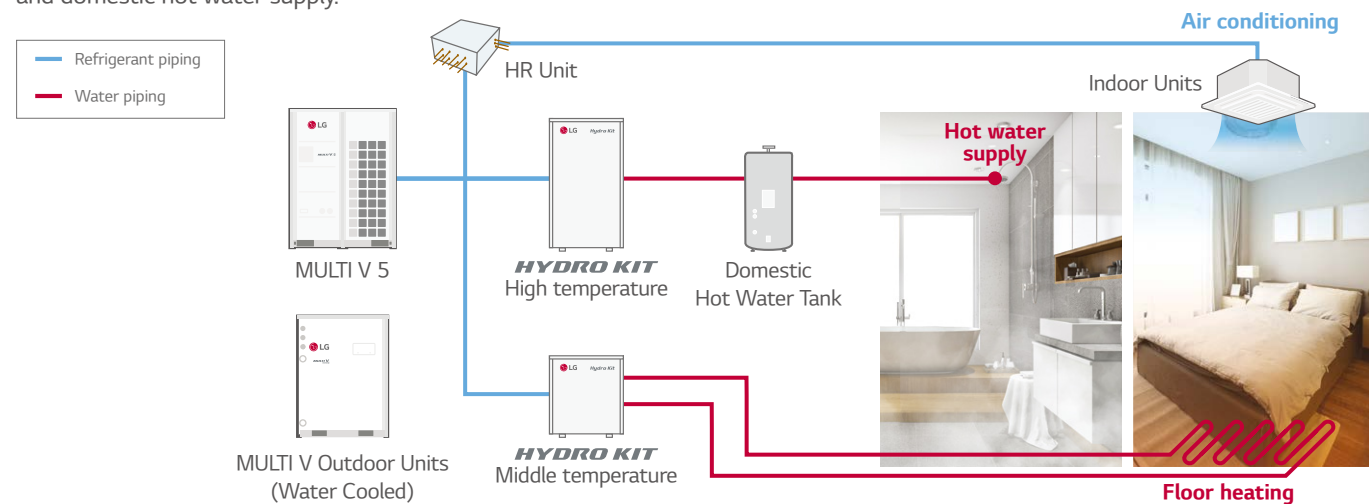

Eco-friendly Green Energy Solution

Green energy solution through the reduction of CO₂ emissions.



Conventional System



HYDRO KIT

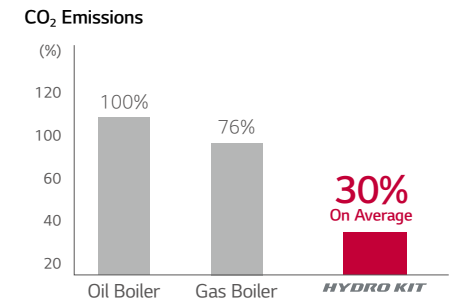

Saving Cost through High Efficiency

Possible to install with equivalent levels of capital cost as a boiler system and minimise energy bills thanks to lower operation costs.

1st Proposal MULTI V 5 HYDRO KIT

(Air Conditioning + Hot Water Supply + Floor Heating)

2nd Proposal MULTI V 5 Air-Conditioning + Gas Boiler

(Hot Water Supply + Floor Heating)

3rd Proposal MULTI V 5 Air-Conditioning + Oil Boiler

(Hot Water Supply + Floor Heating)

Analysis Conditions

- Building Type : Dormitory, Flats
- Cooling / Floor Heating / Sanitary Hot Water for 10 years
- Cooling : MULTI V IV Indoor Unit
- Floor Heating : Medium Temp. HYDRO KIT (1ea)
- Sanitary Hot Water : High Temp. HYDRO KIT (2ea), Sanitary Hot Water Tanks
- Electricity Cost : Average Cost in EU
- Gas Cost : Average Cost in EU
- Oil Cost : Average Cost in EU

Initial Costs

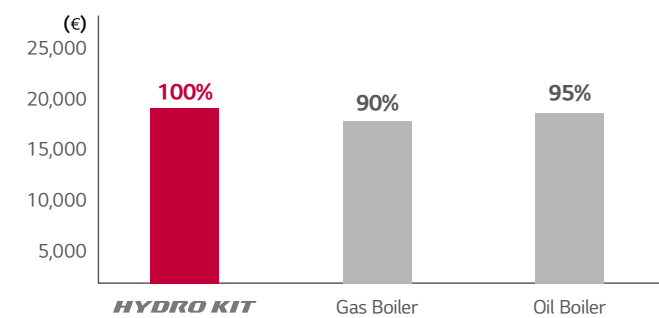

Annual Operating Costs

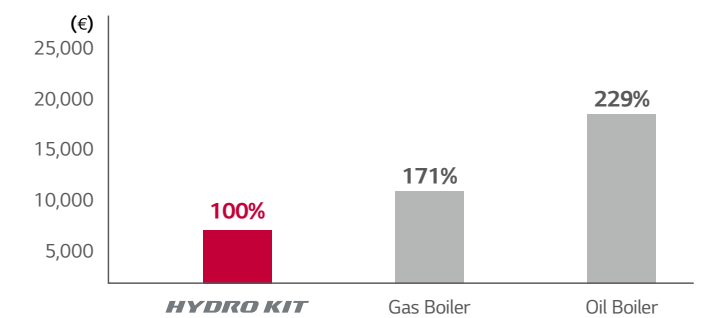

LCC

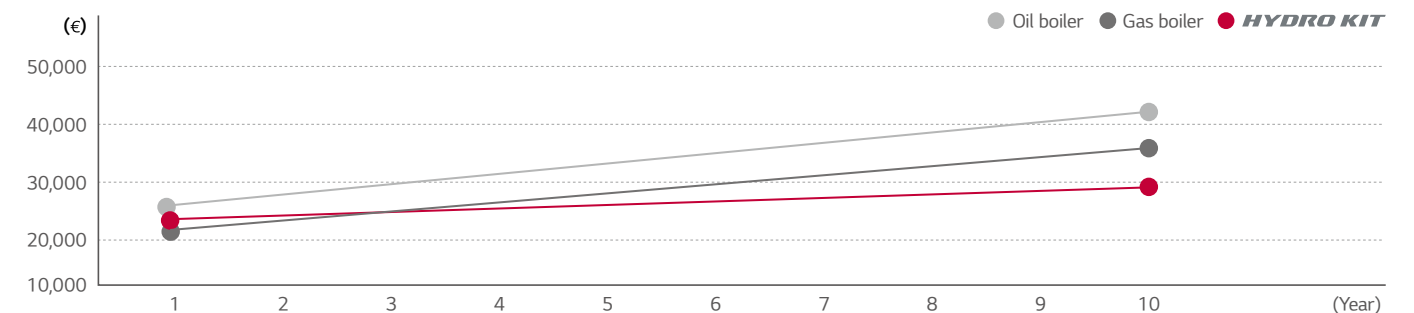

HYDRO KIT

Energy Saving through MULTI V 5 Heat Recovery

Energy costs can be minimized by reusing the wasted heat from indoor units.

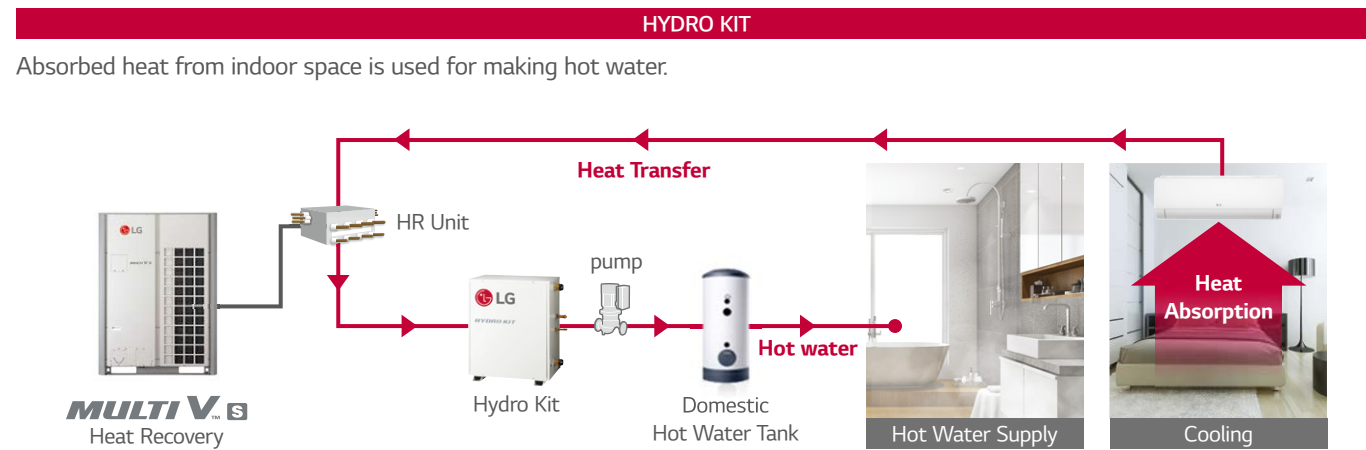
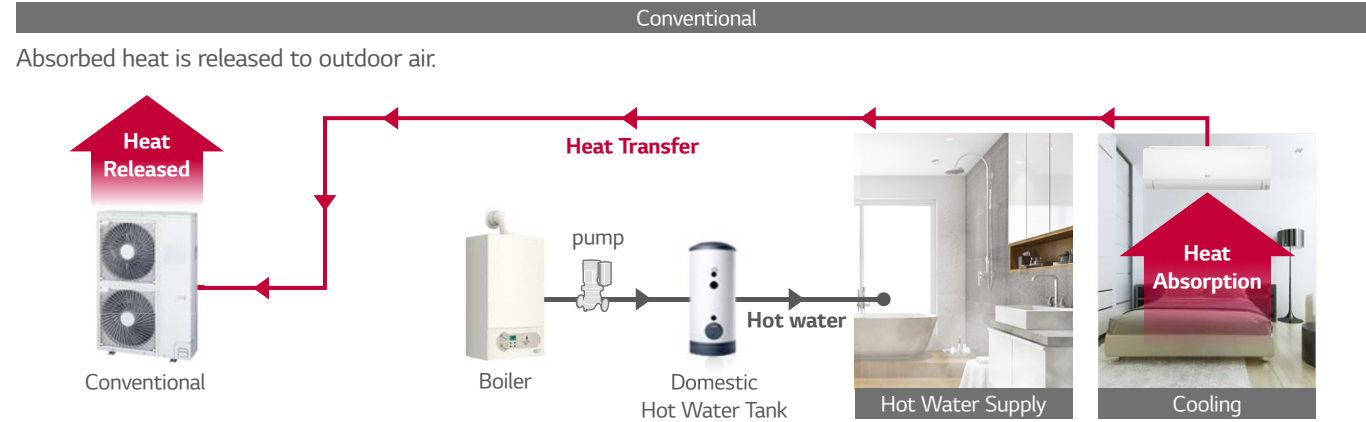

High Temperature Concept of HYDRO KIT

Provides high temperature up to 80°C with dual inverter cascade cycle, applicable for buildings that require large amount of hot water supply.

Dual Inverter Cascade Cycle Technology

- Max 55% improved capacity compared to mid-temp. of HYDRO KIT
- Max 20% reduced heating operating cost compared to mid-temp. of HYDRO KIT
- Cascade R410A to R134A BLDC compressor technology

High Volume of Hot Water

Compared to lower temperature, storing high temperature water in a sanitary tank increases the quantity of mixed water available for the user.

High Temperature HYDRO KIT Cycle Diagram

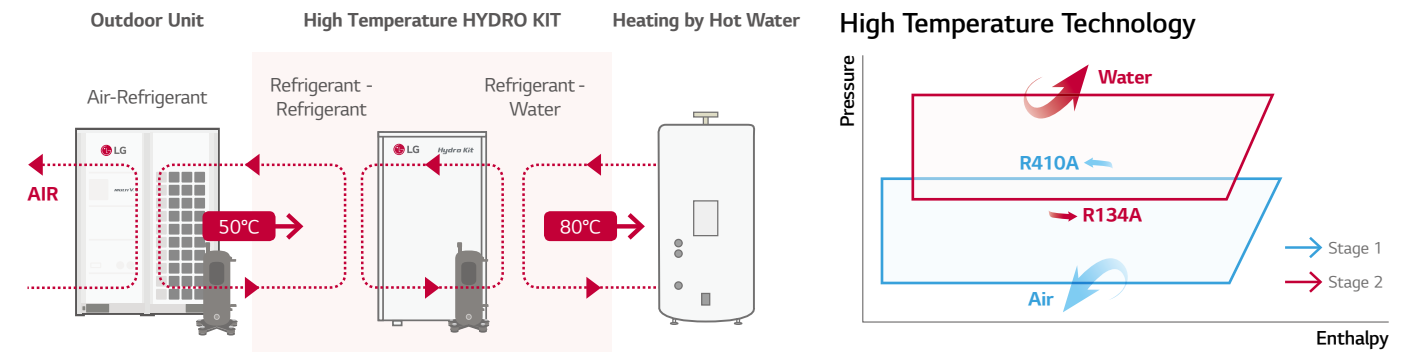

Various Applications

Applicable to a variety of facilities including hospitals, residences and resorts that need floor heating and domestic hot water supply.

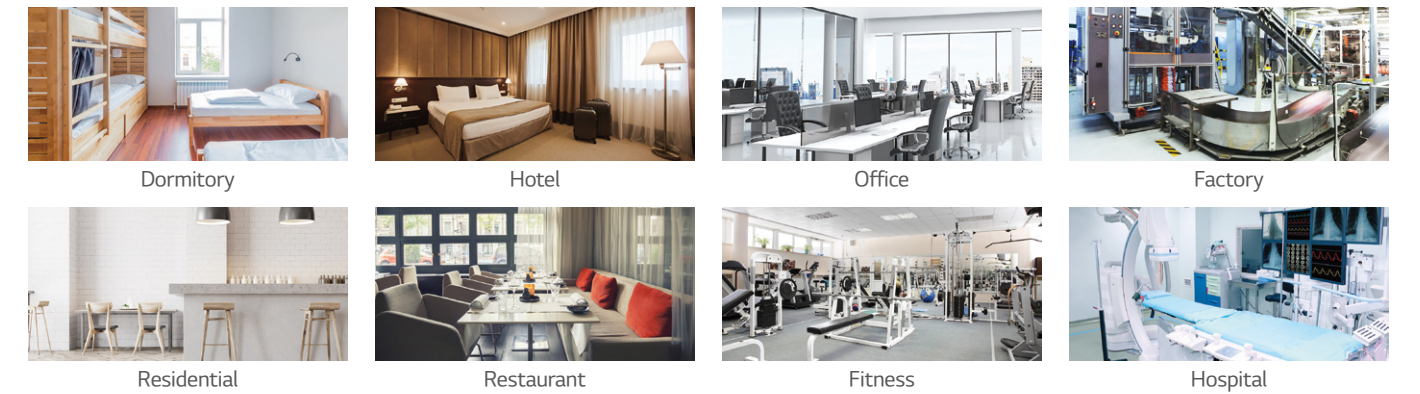

Hotel Application

It is possible to operate cooling and heating constantly at the same time during the summer, to provide hot water for bathrooms by using waste heat energy of indoor cooling.

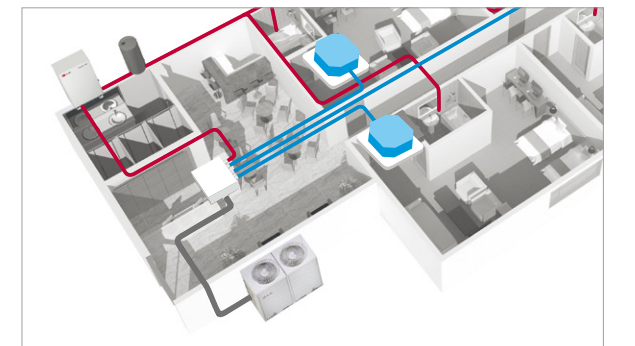

Office Application

Hot water can be supplied at all times in the office by cooling the HR unit to warm up the sanitary tank, using waste energy.

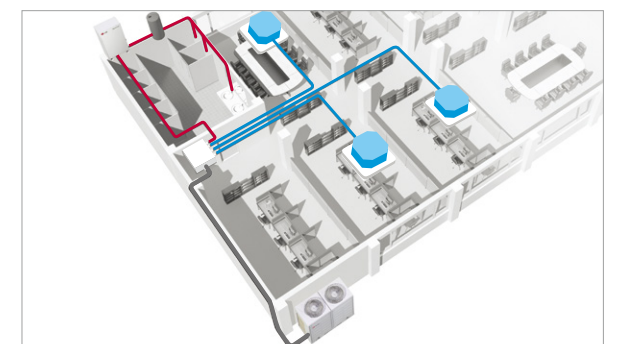

HYDRO KIT

ARNH04GK2A4 / ARNH10GK2A4



Model	Unit	ARNH04GK2A4	ARNH10GK2A4
Cooling Capacity	kW	12.3	28.0
Heating Capacity	kW	13.8	31.5
Power Input	Nominal W	10	10
Exterior Color		Morning Gray	Morning Gray
RAL Code		RAL 7030	RAL 7030
Dimensions (W x H x D)	Body	mm 520 x 631 x 330	520 x 631 x 330
	Shipping	mm 677 x 687 x 418	677 x 687 x 418
Pipe Connections	Liquid Side	mm (inch) Ø9.52(3/8)	Ø9.52(3/8)
	Gas Side	mm (inch) Ø15.88(5/8)	Ø22.2(7/8)
	Drain Pipe (Internal Dia.)	A (inch) 25A (Male PT 1)	25A (Male PT 1)
	Water Pipe Connections	Inlet A (inch) 25A (Male PT 1)	25A (Male PT 1)
	Outlet A (inch) 25A (Male PT 1)	25A (Male PT 1)	25A (Male PT 1)
Weight	Body kg	29.2	33.7
Sound Pressure Levels (H / M / L)	dB (A)	26	26
Power Supply	Ø, V, Hz	1, 220-240, 50	1, 220-240, 50
		1, 220, 60	1, 220, 60
Communication Cable	mm ² x No.	1.0-1.5 x 2C	1.0-1.5 x 2C

1) Nominal : Performance tested under EN14511

Note : 1. Capacities are based on the following conditions :

- Cooling : Indoor 27°C (80.6°F) DB / 19° C (66.2°F) WB, Outdoor 35°C (95°F) DB / 24°C (75.2°F) WB, Water Inlet 23°C (73.4°F) / Outlet 18°C (64.4°F)
- Heating : Indoor 20°C (68°F) DB / 15°C (59°F) WB, Outdoor 7°C (44.6°F) DB / 6°C (42.8°F) WB, Water Inlet 30°C (86°F) / Outlet 35°C (95°F)

2. Piping Length : Interconnected Pipe Length = 7.5m

3. Difference Limit of Elevation (Outdoor - Indoor Unit) is Zero.

4. MULTI V S 4HP (ARUN040GSS0, ARUN040LSS0) cannot be connected to Hydro Kit.

5. MULTI V Water S cannot be connected to Hydro Kit.

6. Anti freezing liquid should be added under 10°C (outdoor temp.) during cooling mode.

Accessories

Chassis	ARNH04GK2A4	ARNH10GK2A4
Drain Pump		-
Cassette Cover		-
Refrigerant Leakage Detector		PRLDNVSO
EEV Kit		-
Independent Power Module		○
Robot Cleaner		-
Pre Filter (washable / anti-fungus)		-
Ion Generator		-
CO2 Sensor		-
Ventilation Kit		-
IR Receiver		-
Zone Controller		-
Dry Contact (with additional accessory)		PDRYCB000 (1 point contact) PDRYCB300(8 points for thermostat compatible)
External Input (1 point)		○
Wi-Fi		PWFMD200

※ ○ : Applied, - : Not applied

Option : Refer to model name in table

ARNH04GK3A4/ ARNH08GK3A4



Model	Unit	ARNH04GK3A4	ARNH08GK3A4
Heating Capacity	kW	13.8	25.2
Power Input	Nominal W	2,300	5,000
Exterior Color		Morning Gray	Morning Gray
RAL Code		RAL 7030	RAL 7030
Dimensions (W x H x D)	Body	mm 520 x 1,080 x 330	520 x 1,080 x 330
	Shipping	mm 682 x 1,168 x 423	682 x 1,168 x 423
Pipe Connections	Liquid Side	mm (inch) Ø9.52(3/8)	Ø9.52(3/8)
	Gas Side	mm (inch) Ø15.88(5/8)	Ø19.05(3/4)
	Drain Pipe (Internal Dia.)	A (inch) 25A (Male PT 1)	25A (Male PT 1)
	Water Pipe Connections	Inlet A (inch) 25A (Male PT 1)	25A (Male PT 1)
	Outlet A (inch) 25A (Male PT 1)	25A (Male PT 1)	25A (Male PT 1)
Weight	Body kg	87.0	91.0
Sound Pressure Levels (H / M / L)	dB (A)	43	46
Power Supply	Ø, V, Hz	1, 220-240, 50	1, 220-240, 50
		1, 220, 60	1, 220, 60
Communication Cable	mm ² x No.	1.0-1.5 x 2C	1.0-1.5 x 2C

1) Nominal : Performance tested under EN14511

Note : 1. Capacities are based on the following conditions :

- Heating : Indoor 20°C (68°F) DB / 15°C (59°F) WB, Outdoor 7°C (44.6°F) DB / 6°C (42.8°F) WB, Water Inlet 55°C (131°F) / Outlet 65°C (149°F)

2. Piping Length : Interconnected Pipe Length = 7.5m

3. Difference Limit of Elevation (Outdoor - Indoor Unit) is Zero.

4. MULTI V S 4HP (ARUN040GSS0, ARUN040LSS0) cannot be connected to Hydro Kit.

5. MULTI V Water S cannot be connected to Hydro Kit.

Accessories

Chassis	ARNH04GK3A4	ARNH08GK3A4
Drain Pump		-
Cassette Cover		-
Refrigerant Leakage Detector		PRLDNVSO
EEV Kit		-
Independent Power Module		○
Robot Cleaner		-
Pre Filter (washable / anti-fungus)		-
Ion Generator		-
CO2 Sensor		-
Ventilation Kit		-
IR Receiver		-
Zone Controller		-
Dry Contact (with additional accessory)		PDRYCB000 (1 point contact) PDRYCB300(8 points for thermostat compatible)
External Input (1 point)		○
Wi-Fi		PWFMD200

※ ○ : Applied, - : Not applied

Option : Refer to model name in table

VENTILATION SOLUTIONS

ERV / ERV WITH DX COIL



ERV

Necessity of ERV

Natural ventilation loss cooling, heating energy when exhausting polluted air inside. Heat exchanger in ERV collects the cooling, heating energy to save energy while supplying fresh air.

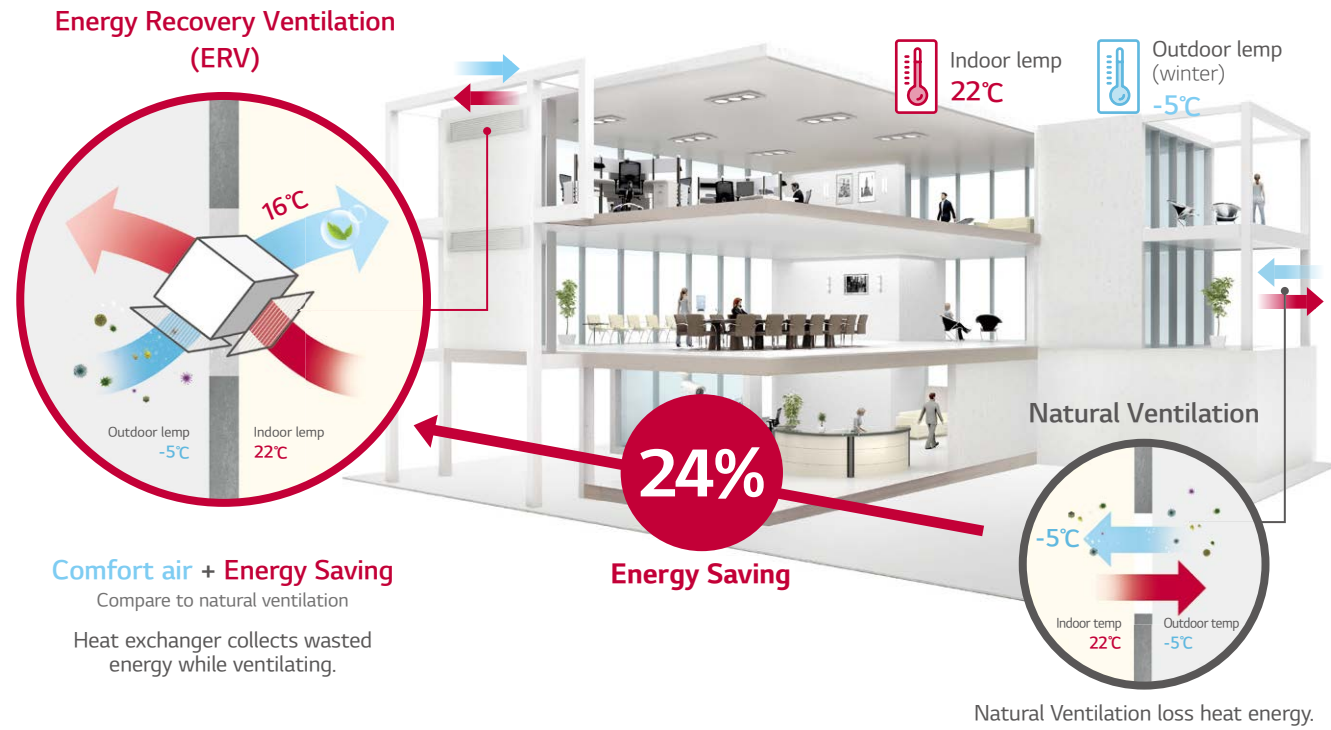

High Efficiency Heat Exchanger

Efficiency and comfort is ensured through the high-efficiency energy recovery central core which recovers energy from the indoor air and transfers it to the fresh incoming air without mixing airstream.

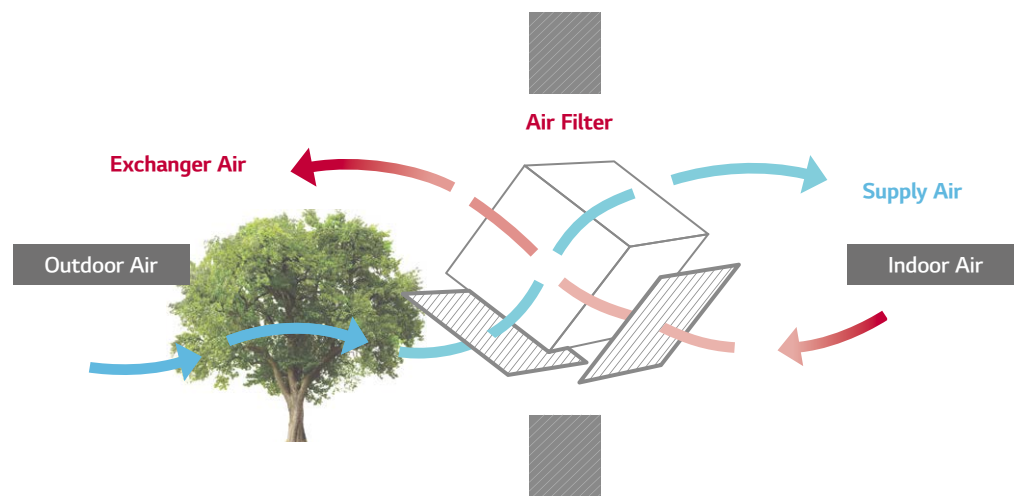

Interlocking with Air Conditioning System

- LG ERV can be interlocked with air conditioners and controlled individually.
- This function can be operated when the system is connected with a remote control

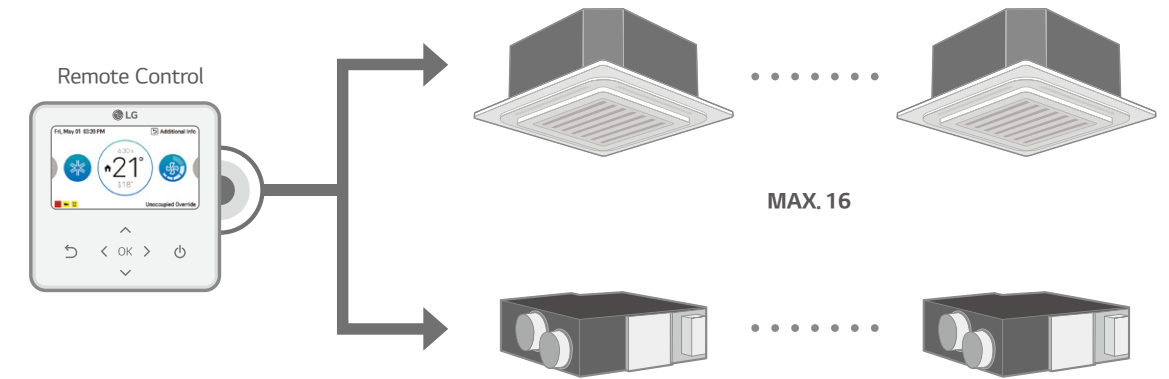

Compulsory Exhausting System

The exhausting system using high static and sirocco fan removes contaminants effectively from indoor air. Supply and exhaust air flows are completely separated in the total heat exchanger, LG ERV can filter out the impurities before supplying outdoor air and make indoor air fresh and healthy.

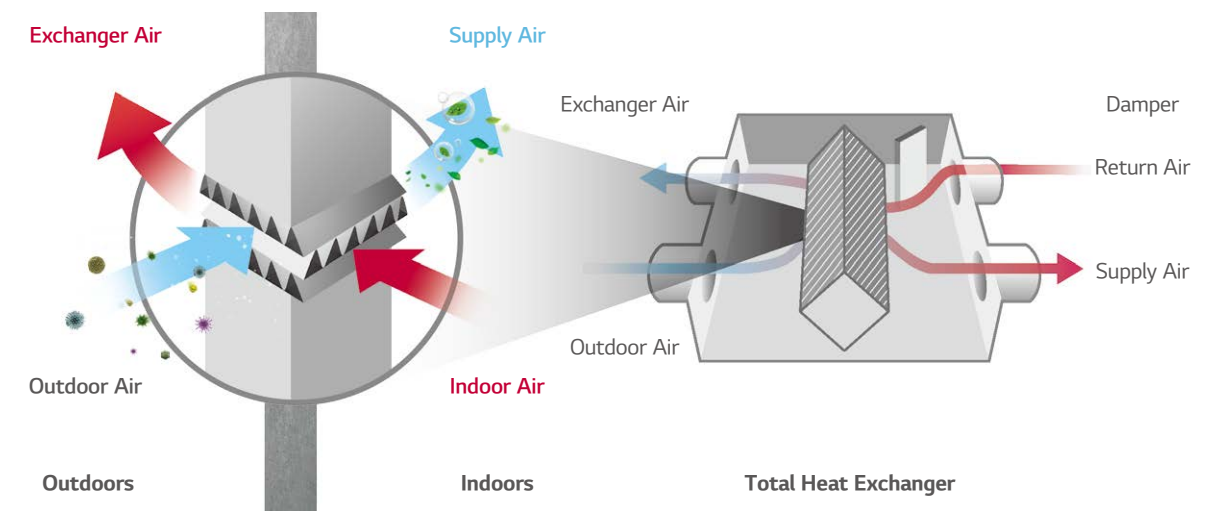

Night Time Free Cooling

Discharge the indoor heat in the summer night and supply cool outdoor air to indoors. so it can save energy.

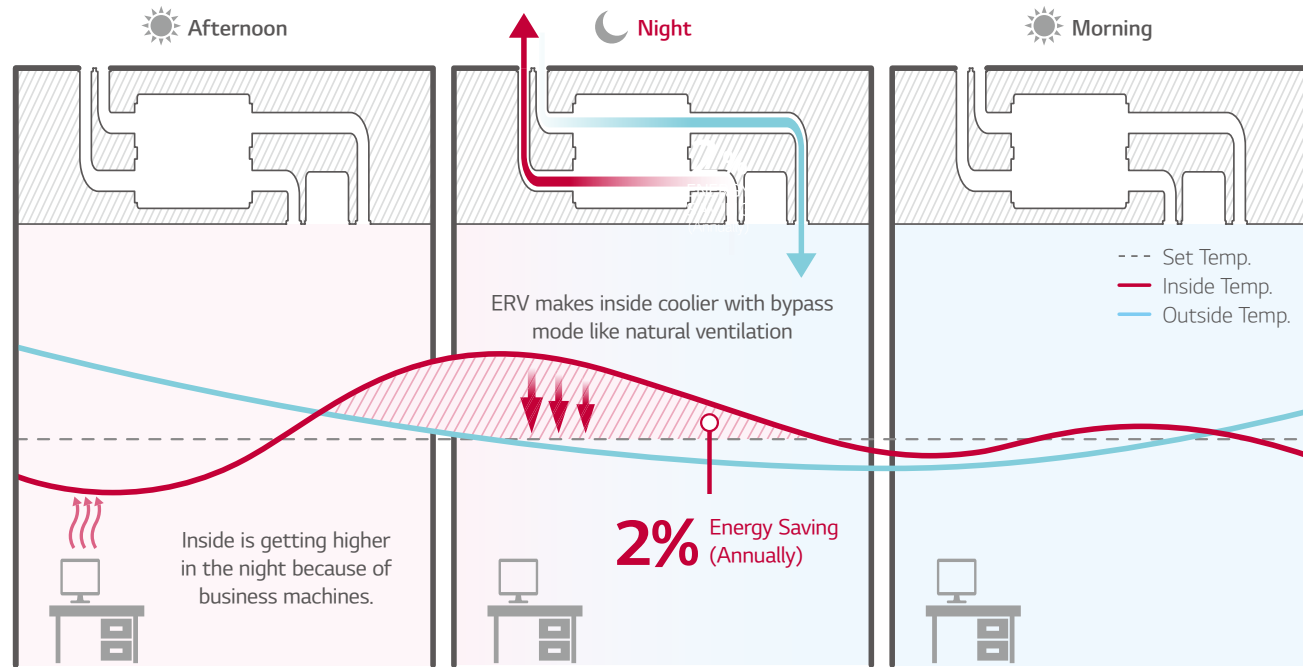

* This function is operated with 'Night Time Free Cooling' on remote controller. (with MULTI V only)
 ** Energy saving ratio can be differed by weather condition.
 ※ Test Condition
 - Office (49,000ft²) / Occupancy : 30 / Area : London, UK
 - ERV (1000 CMH) + MULTI V 4 (12HP) Unit Combination
 - Other conditions are subject to BREEAM.

Delay Operation

When you turn on the air conditioner and ERV at the same time, Delay Operation can reduce unnecessary heating and cooling energy loss slows down automatically ERV operation.

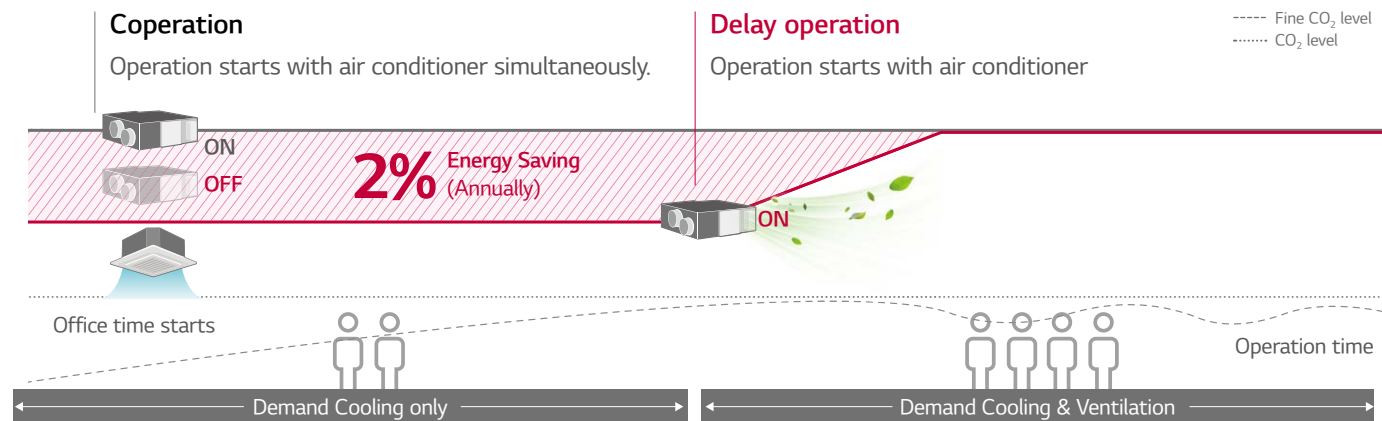

* This function is operated with 'Night Time Free Cooling' on remote controller. (with MULTI V only)
 ** Energy saving ratio can be differed by weather condition.
 ※ Test Condition
 - Office (49,000ft²) / Occupancy : 30 / Area : London, UK
 - ERV (1000 CMH) + MULTI V 4 (12HP) Unit Combination
 - Other conditions are subject to BREEAM.

CO₂ Auto Operation

LG ERV reduces energy loss with auto fan speed control following CO₂ level

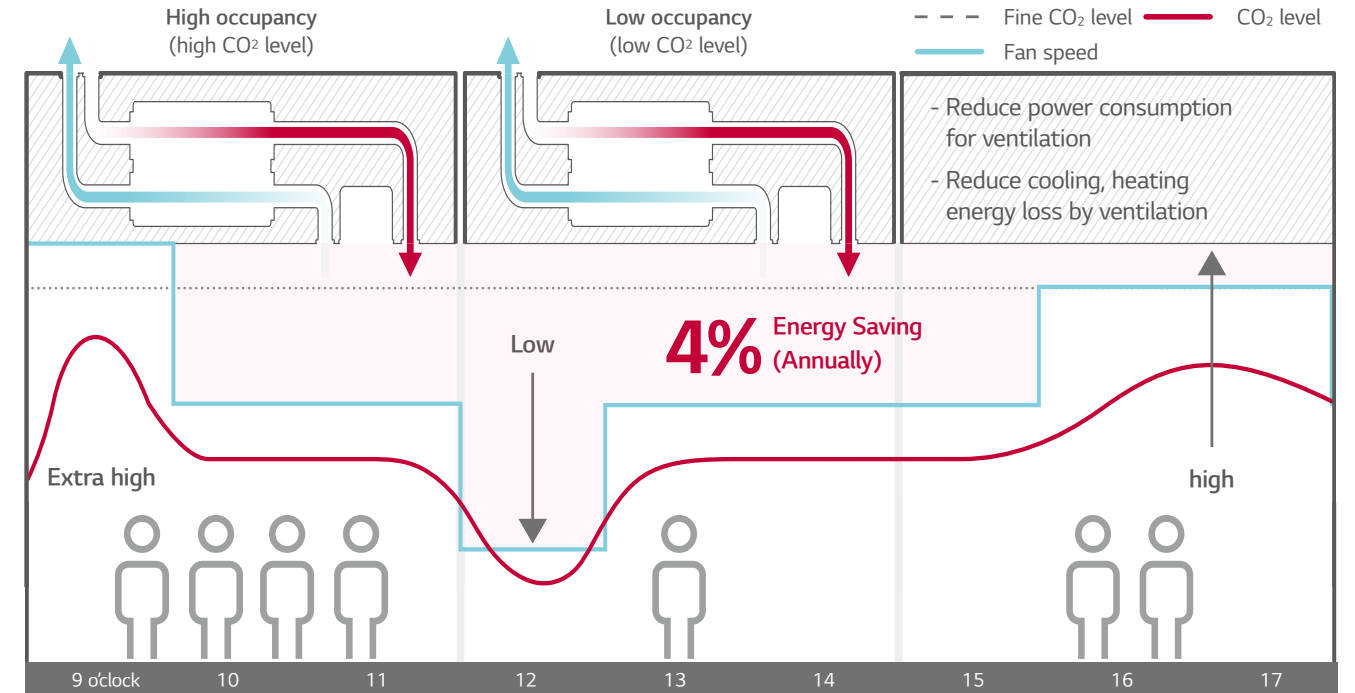

* This function is operated with 'Night Time Free Cooling' on remote controller. (with MULTI V only)
 ** Energy saving ratio can be differed by weather condition.
 ※ Test Condition
 - Office (49,000ft²) / Occupancy : 30 / Area : London, UK
 - ERV (1000 CMH) + MULTI V 4 (12HP) Unit Combination
 - Other conditions are subject to BREEAM.

Seasonal Auto Operation

LG ERV senses outdoor temperature and operates automatically following weather condition.

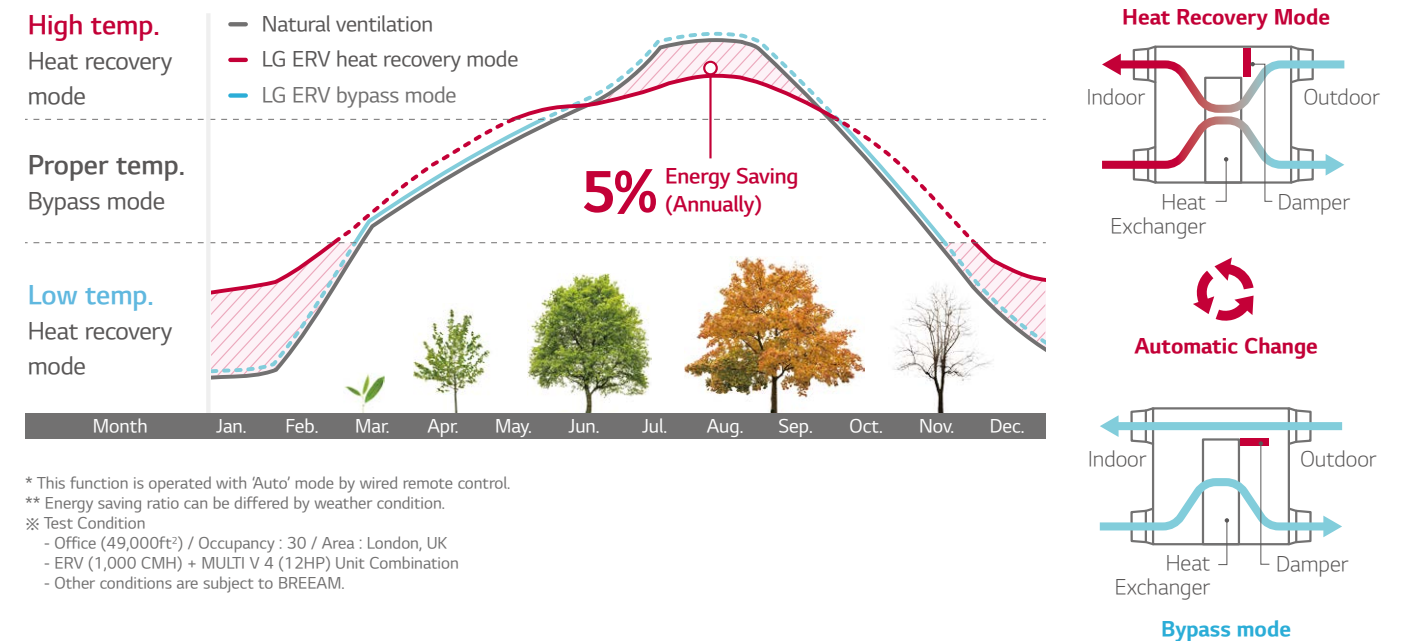

* This function is operated with 'Auto' mode by wired remote control.
 ** Energy saving ratio can be differed by weather condition.
 ※ Test Condition
 - Office (49,000ft²) / Occupancy : 30 / Area : London, UK
 - ERV (1,000 CMH) + MULTI V 4 (12HP) Unit Combination
 - Other conditions are subject to BREEAM.

ERV

CO₂ Level Monitoring

CO₂ sensor senses CO₂ level in the room. Users can monitor CO₂ level on new wired remote controller, and ERV controls the fan speed automatically following the level.

CO₂ Level Visualization

CO₂ sensor senses indoor CO₂ level and displays it on new wired remote controller.

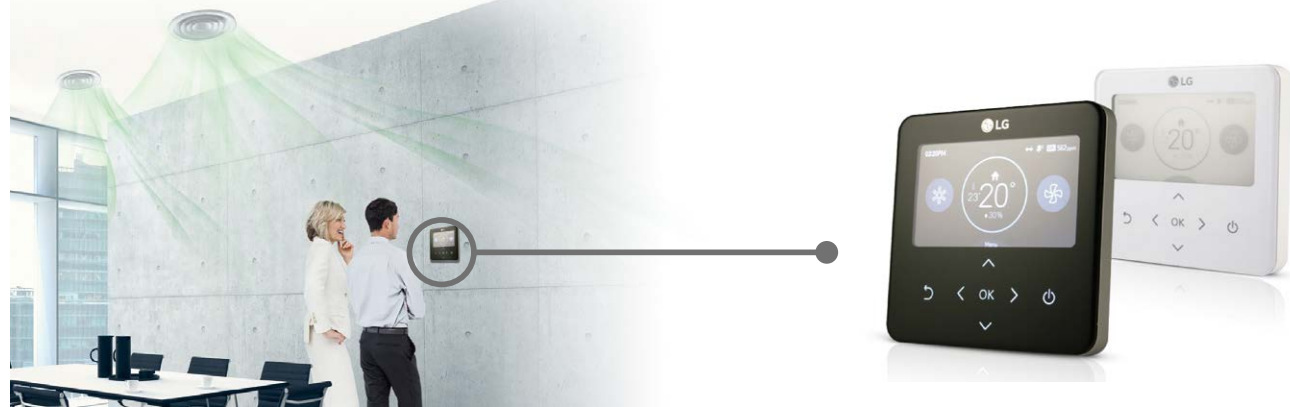

Main display

If the CO₂ level is above 900ppm in the room, the red mark is on.



* The remote controller screen image may change.
* Applicable to only Standard III, Premium remote controller.

Further information

CO₂ level and room condition are displayed continuously.

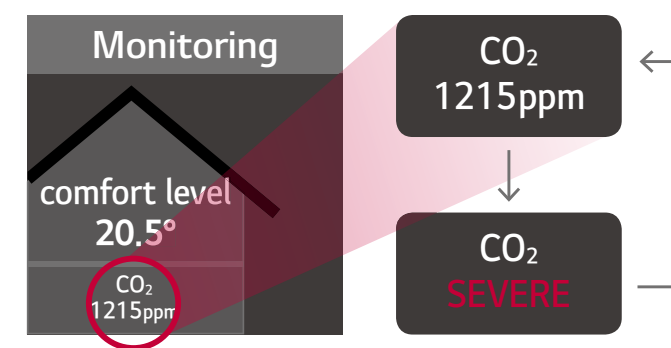

CO₂ Concentration Control

Using CO₂ sensor, LG ERV controls exhaust air flow automatically to keep indoor air fresh under settled CO₂ concentration.

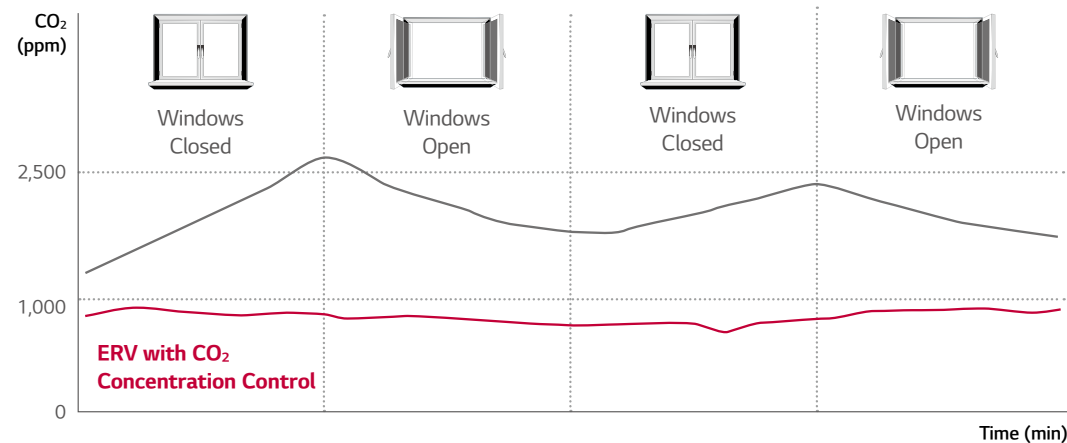
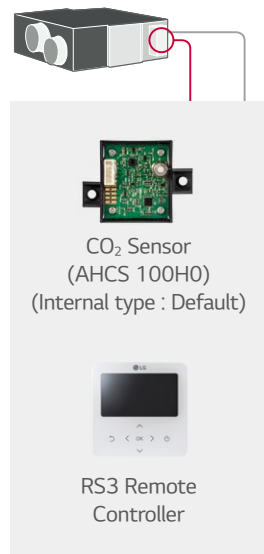

External Static Pressure Control

The high static pressure fan can control the air volume depending on the length of the duct. It is also easy to control the pressure level by using the remote controller for a more flexible duct installation and easier testing.

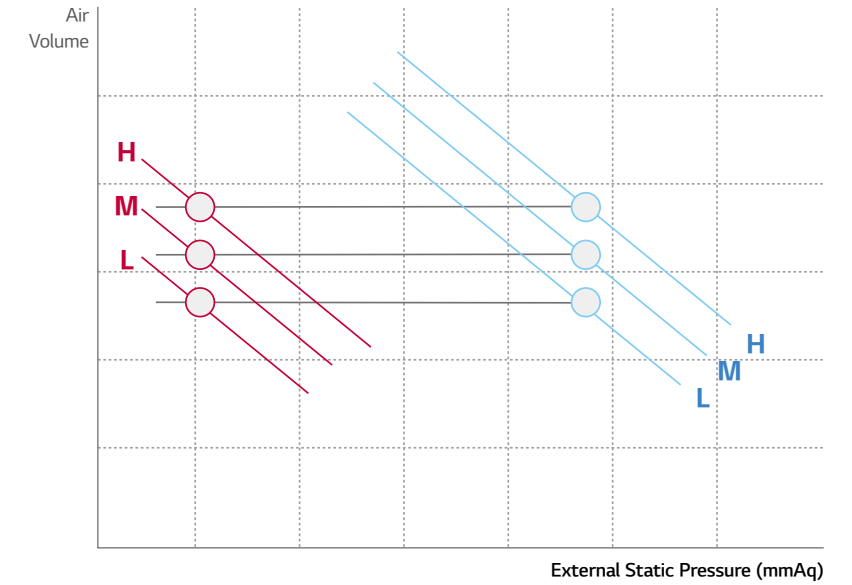

Fast Ventilation Mode

Fast ventilation mode prevents the spread of contaminants under negative indoor pressure, and makes indoor air fresh and comfortable quickly.

Only Exhausting

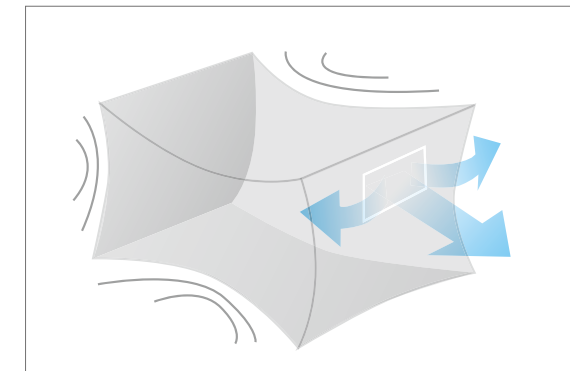

Exhausting operation causes negative indoor air pressure, and cannot fully ventilate.

Fast Ventilation Mode

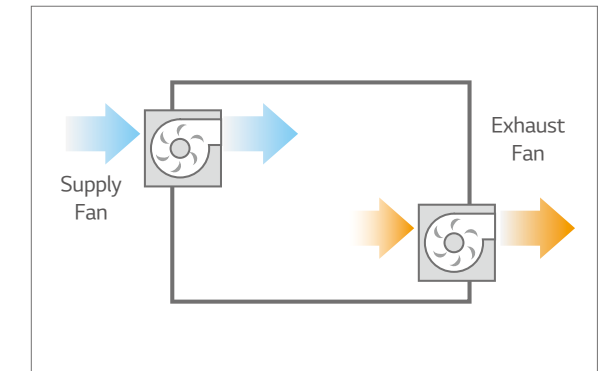

ERV

High Durability

LG ERV durability is increased through bacteria-resistant material of heat exchanger and Corrosion protection coating. It prevents shortening product life due to corrosion and mold and supplies high quality air to inside by minimizing the bacteria.

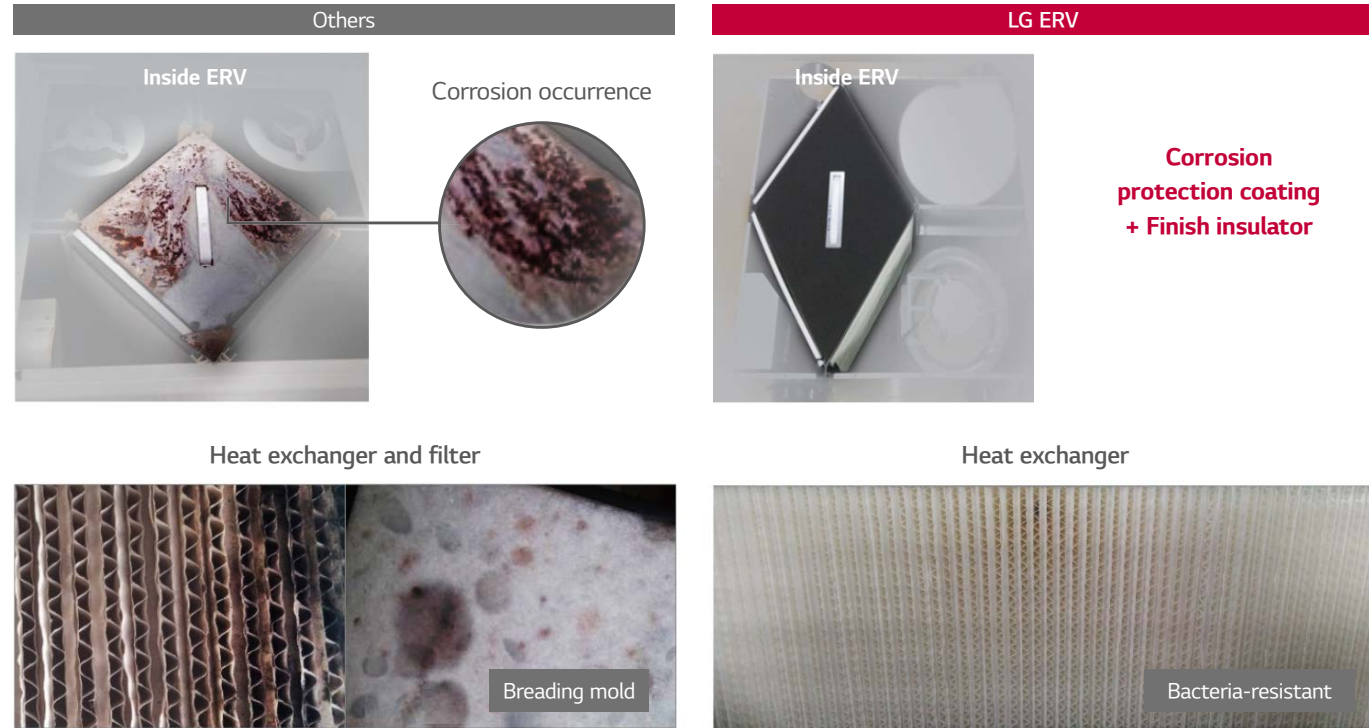

Easy Controller

Wired remote controller is easy for usage.



Easy

- Navigation buttons, easy to use.
- Easy installation setting

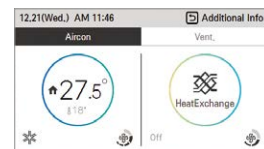

Convenient

- Flexible display
- Dual display with air conditioner.
- Zoom selected directory to increase legibility.

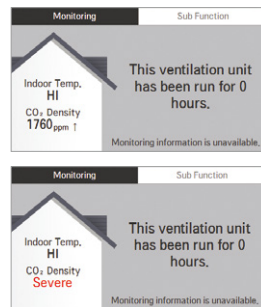

Visible

- Indoor CO₂ level
- Alarm for filter change / Remained time to change filters

Group Control

One wired remote control up to sixteen ERV (including air conditioning) You can reduce the remote installation costs and enjoy good looking interior wall effect.

Several units combination

16 units group control is available with 1 remote controller.



1) 16 units (Including ERV, air conditioner) + 1 remote controller

Good looking interior



Controller & installation cost saving



Easy Cleaning and Filter Change

It is easy and convenient to change and clean the filter.

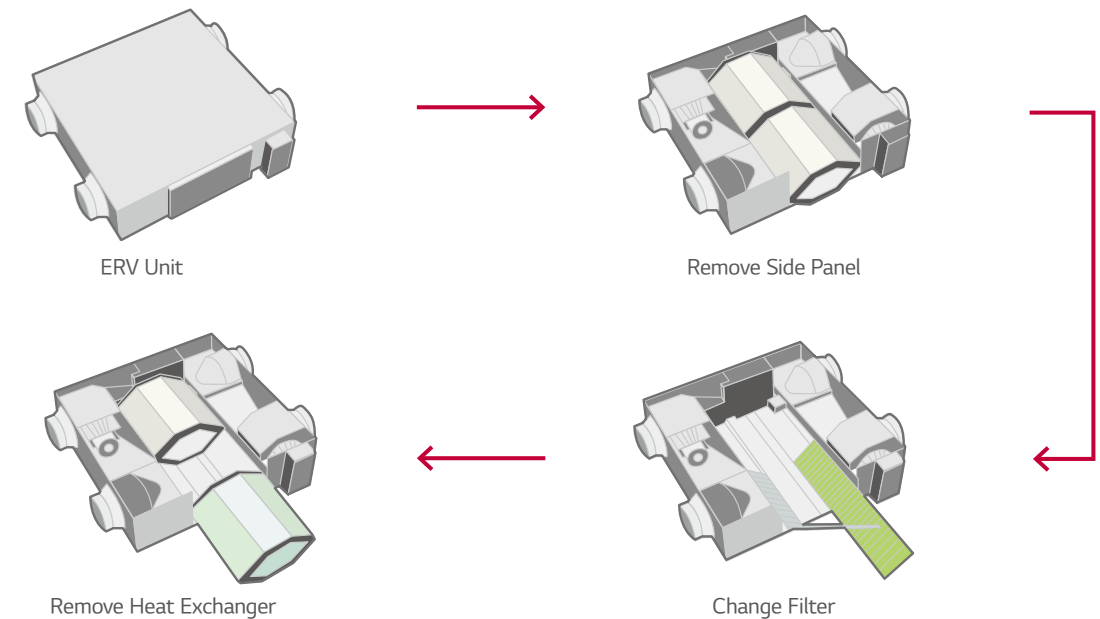

LZ-H025GBA4 / LZ-H035GBA4 / LZ-H050GBA4



Model		LZ-H025GBA4	LZ-H035GBA4	LZ-H050GBA4
Nominal Capacity	CMH (CFM)	250 (147)	350 (206)	500 (294)
Power Supply	Ø / V / Hz	1 / 220-240 / 50, 60		
ERV Mode	Step	SUPER-HIGH / HIGH / LOW		
	Current	SH / H / L	Amps	0.70 / 0.60 / 0.42
	Power Input	SH / H / L	W	97 / 78 / 52
	Air Flow	SH / H / L	CMH (CFM)	250 / 250 / 150 (147 / 147 / 88)
	External Static Pressure	SH / H / L	Pa (inWTR)	100 / 70 / 50 (0.40 / 0.28 / 0.20)
	Temperature Exchange Efficiency	SH / H / L	%	80 / 80 / 83
	Enthalpy Exchange Efficiency	Heating (SH / H / L)	%	70 / 70 / 72
		Cooling (SH / H / L)	%	66 / 66 / 68
	Noise Level (Sound Level, 1.5m)	SH / H / L	dB (A)	29 / 28 / 24
	Bypass Mode	Step	SUPER-HIGH / HIGH / LOW	
Current		SH / H / L	Amps	0.70 / 0.60 / 0.42
Power Input		SH / H / L	W	97 / 78 / 52
Air Flow		SH / H / L	CMH (CFM)	250 / 250 / 150 (147 / 147 / 88)
External Static Pressure		SH / H / L	Pa (inWTR)	100 / 70 / 50 (0.40 / 0.28 / 0.20)
Noise Level (Sound Level, 1.5m)		SH / H / L	dB (A)	29 / 29 / 25
Heat Exchanger	Type	Air to air cross flow heat exchange		
Net Weight	kg	44	44	44
Dimension	W x H x D	mm	988 x 273 x 1,014	988 x 273 x 1,014
Duct work*	Qty	EA	4	
	Size (Ø)	mm	Ø200	
Supply Air Fan	Qty	EA	1	
	Type	-	Direct-Drive (Sirocco Fan)	
Exhaust Air Fan	Qty	EA	1	
	Type	-	Direct-Drive (Sirocco Fan)	
Filters (Default)	Qty	EA	2	2
	Type	-	Cleanable fibrous fleeces	
	Size (W x H x D)	mm	855 x 10 x 160	855 x 6 x 230
Filters (Optional)	Model	-	AHFT035H0	AHFT050H0
	Qty	EA	2	2
	Type	-	F7	F7
	Size (W x H x D)	mm	423.5 x 132 x 25	425 x 194 x 25
Dry Contact	-	PDRYCB000		

- Note : 1. ERV mode : Total Heat Recovery Ventilation mode
 2. * : Refer to dimensional drawings.
 3. Noise level : - The operating conditions are assumed to be standard
 - Sound measured at 1.5m below the center the body.
 - Sound level will vary depending on a range of factors such as the construction(acoustic absorption coefficient) of particular room in which the equipment is installed.
 - The sound level at the air discharge port is about 8 dB(A) higher than the unit's operating sound.
 4. Temperature and Enthalpy Exchange Efficiency at cooling Indoor Temperature : 26.5°C DB, 64.5% RH, Outdoor Temperature : 34.5°C DB, 75% RH
 5. Temperature and Enthalpy Exchange Efficiency at heating Indoor Temperature : 20.5°C DB, 59.5% RH, Outdoor Temperature : 5°C DB, 65% RH
 6. Temperature Exchange efficiency is tested at heating condition.
 7. F7 Filter is 2 pieces in 1 filter package

Premium	Standard III	Standard II	CO ₂ Sensor
PREMTA000 PREMTA000A PREMTA000B	PREMTB100	PREMTBB01 PREMTB001	AHCS100H0 (Internal Type)

LZ-H080GBA4 / LZ-H100GBA4
LZ-H150GBA4 / LZ-H200GBA4



Model		LZ-H080GBA4	LZ-H100GBA4	LZ-H150GBA4	LZ-H200GBA4
Nominal Capacity	CMH (CFM)	800 (471)	1,000 (589)	1,500 (883)	2,000 (1,177)
Power Supply	Ø / V / Hz	1 / 220-240 / 50, 60			
ERV Mode	Step	SUPER-HIGH / HIGH / LOW			
	Current	SH / H / L	Amps	2.77 / 2.16 / 1.44	3.41 / 2.90 / 1.76
	Power Input	SH / H / L	W	390 / 280 / 187	480 / 385 / 210
	Air Flow	SH / H / L	CMH (CFM)	800 / 800 / 660 (471 / 471 / 388)	1,000 / 1,000 / 800 (589 / 589 / 471)
	External Static Pressure	SH / H / L	Pa (inWTR)	200 / 110 / 60 (0.80 / 0.44 / 0.24)	160 / 90 / 50 (0.64 / 0.36 / 0.20)
	Temperature Exchange Efficiency	SH / H / L	%	79 / 79 / 82	77 / 77 / 78
	Enthalpy Exchange Efficiency	Heating (SH / H / L)	%	72 / 72 / 74	70 / 70 / 72
		Cooling (SH / H / L)	%	63 / 63 / 66	59 / 59 / 63
	Noise Level (Sound Level, 1.5m)	SH / H / L	dB (A)	40 / 37 / 31	41 / 38 / 32
	Bypass Mode	Step	SUPER-HIGH / HIGH / LOW		
Current		SH / H / L	Amps	2.77 / 2.16 / 1.44	3.41 / 2.90 / 1.76
Power Input		SH / H / L	W	390 / 280 / 187	480 / 385 / 210
Air Flow		SH / H / L	CMH (CFM)	800 / 800 / 660 (471 / 471 / 388)	1,000 / 1,000 / 800 (589 / 589 / 471)
External Static Pressure		SH / H / L	Pa (inWTR)	200 / 110 / 60 (0.80 / 0.44 / 0.24)	160 / 90 / 50 (0.64 / 0.36 / 0.20)
Noise Level (Sound Level, 1.5m)		SH / H / L	dB (A)	41 / 38 / 32	41 / 39 / 33
Heat Exchanger	Type	Air to air cross flow heat exchange			
Net Weight	kg	62	140		
Dimension	W x H x D	mm	1,062 x 365 x 1,140	1,313 x 738 x 1,140	
Duct work*	Qty	EA	4	4 + 2	
	Size (Ø)	mm	Ø250	Ø250 + Ø350	
Supply Air Fan	Qty	EA	1	2	
	Type	-	Direct-Drive (Sirocco Fan)		
Exhaust Air Fan	Qty	EA	1	2	
	Type	-	Direct-Drive (Sirocco Fan)		
Filters (Default)	Qty	EA	2	4	
	Type	-	Cleanable fibrous fleeces		
	Size (W x H x D)	mm	1,056 x 6 x 212.5		
Filters (Optional)	Model	-	AHFT100H0		
	Qty	EA	2	4	
	Type	-	F7		
	Size (W x H x D)	mm	520 x 192 x 25		
Dry Contact	-	PDRYCB000			

- Note : 1. ERV mode : Total Heat Recovery Ventilation mode
 2. * : Refer to dimensional drawings.
 3. Noise level : - The operating conditions are assumed to be standard
 - Sound measured at 1.5m below the center the body.
 - Sound level will vary depending on a range of factors such as the construction(acoustic absorption coefficient) of particular room in which the equipment is installed.
 - The sound level at the air discharge port is about 8 dB(A) higher than the unit's operating sound.
 4. Temperature and Enthalpy Exchange Efficiency at cooling Indoor Temperature : 26.5°C DB, 64.5% RH, Outdoor Temperature : 34.5°C DB, 75% RH
 5. Temperature and Enthalpy Exchange Efficiency at heating Indoor Temperature : 20.5°C DB, 59.5% RH, Outdoor Temperature : 5°C DB, 65% RH
 6. Temperature Exchange efficiency is tested at heating condition.
 7. F7 Filter is 2 pieces in 1 filter package

Premium	Standard III	Standard II	CO ₂ Sensor
PREMTA000 PREMTA000A PREMTA000B	PREMTB100	PREMTBB01 PREMTB001	AHCS100H0 (Internal Type : Default)

ERV

LZ-H025GBA4



Ventilation

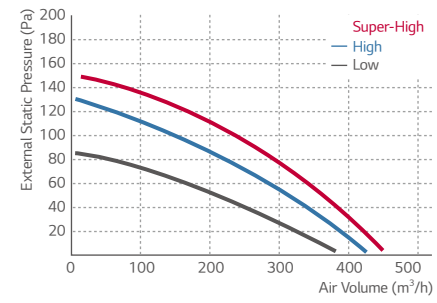

Efficiency

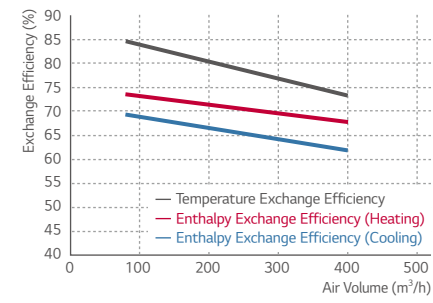

LZ-H100GBA4



Ventilation

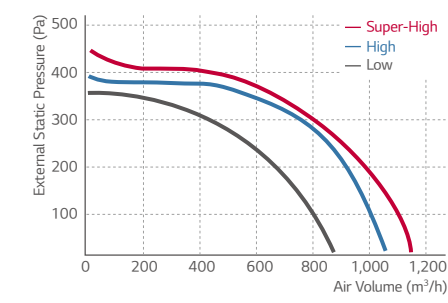

Efficiency

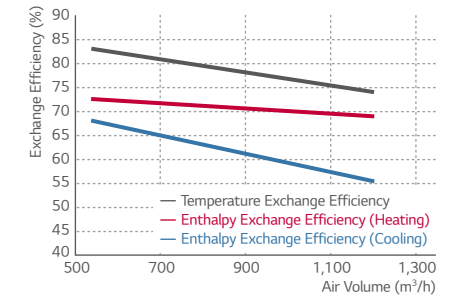

LZ-H035GBA4



Ventilation

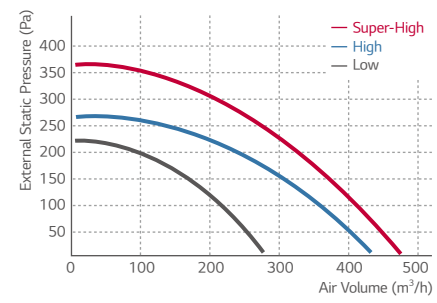

Efficiency

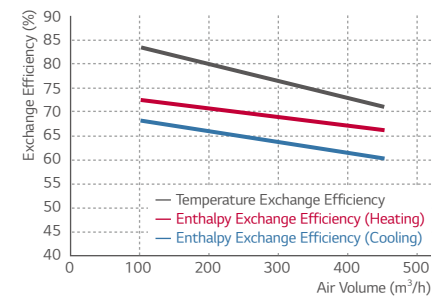

LZ-H150GBA4



Ventilation

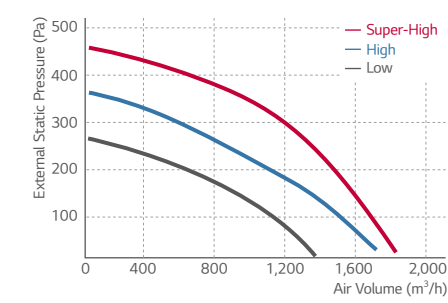

Efficiency

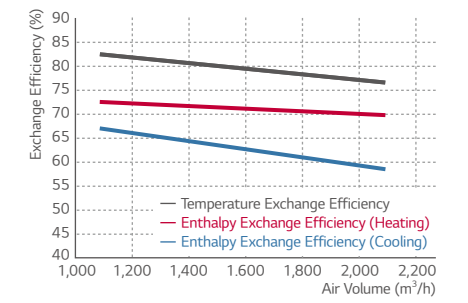

LZ-H050GBA4



Ventilation

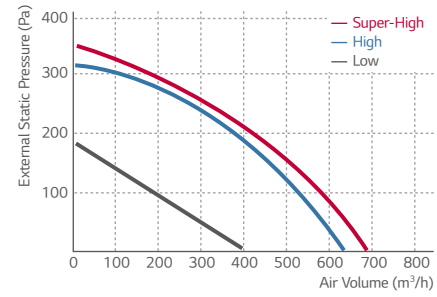

Efficiency

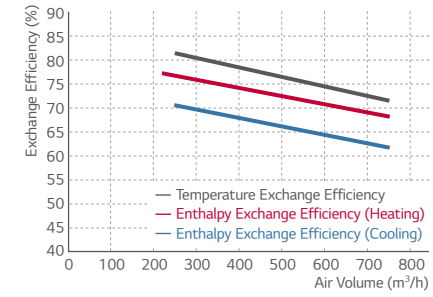

LZ-H200GBA4



Ventilation

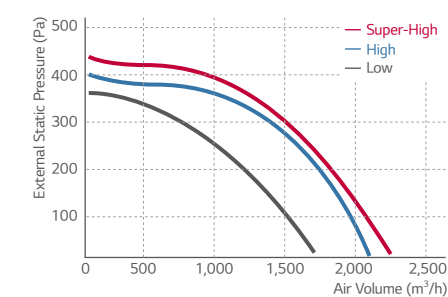

Efficiency

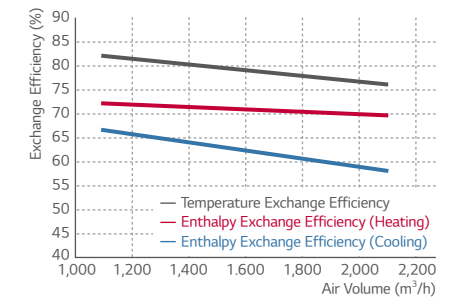

LZ-H080GBA4



Ventilation

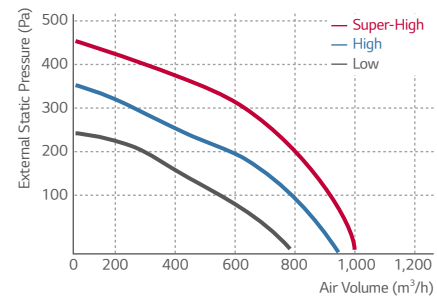

Efficiency

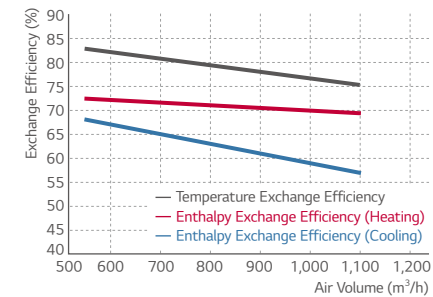

ERV WITH DX COIL

Providing Cool & Warm Fresh Air

During the summer, ERV DX can transform outdoor warm air into cool air for indoors, and it can prevent cold drafts during the winter by supplying warm air.

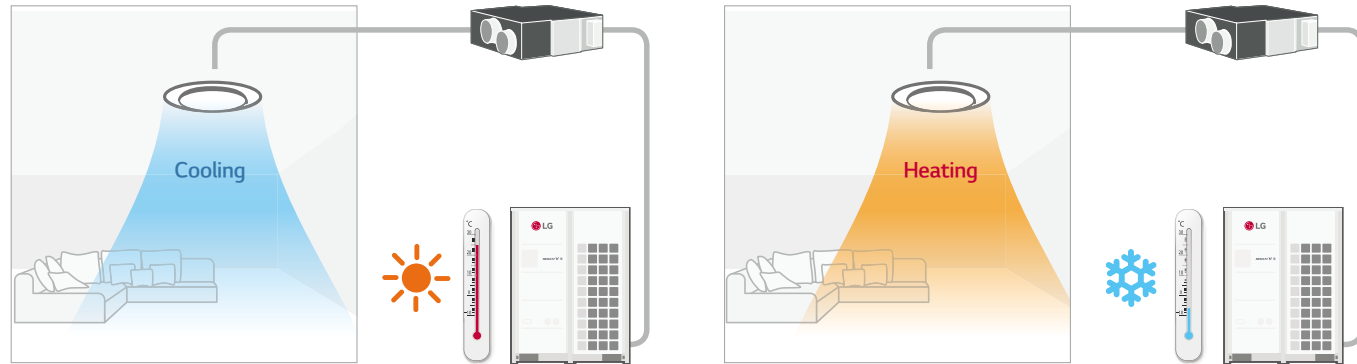

Total Air Conditioning Solution

LG ERV DX can be used as a Total Air Conditioning Solution. It can control condition of incoming air with the DX coil and humidifier for making comfortable indoor air. In the summer, LG ERV DX controls the air indoors by cooling and dehumidifying incoming air. In winter, it can provide warm air by heating and humidifying the incoming air.

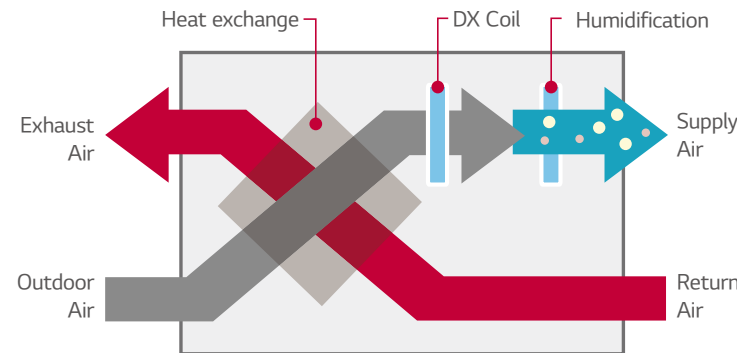

Interlocking with MULTI V

LG ERV DX can be interlocked with MULTI V. It can be controlled individually by a wired remote controller connected to MULTI V indoor units.

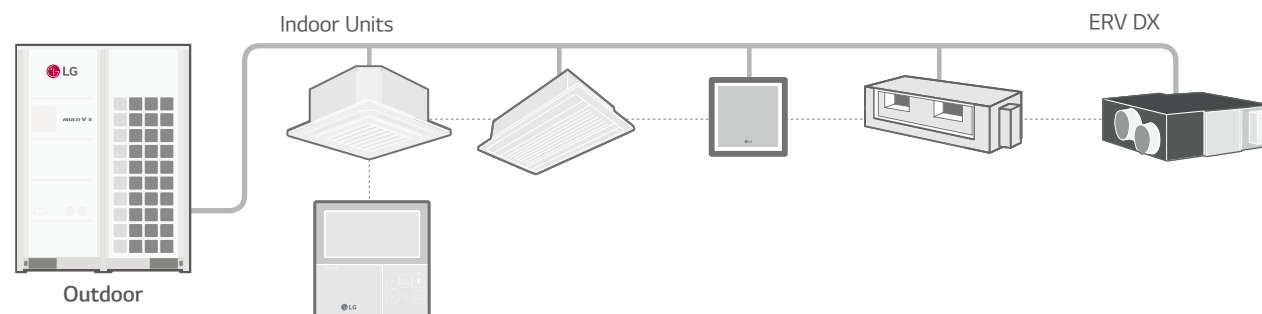

LZ-H050GXH4 / LZ-H080GXH4 / LZ-H100GXH4
LZ-H050GXN4 / LZ-H080GXN4 / LZ-H100GXN4



Model		LZ-H050GXH4	LZ-H080GXH4	LZ-H100GXH4	LZ-H050GXN4	LZ-H080GXN4	LZ-H100GXN4	
Fresh Air Conditioning Load	Cooling	4.93	7.46	9.12	4.93	7.46	9.12	
	Heating	6.73	9.80	11.72	6.73	9.80	11.72	
Temperature Exchange Efficiency	SH / H / L	86 / 86 / 87	80 / 80 / 81	76 / 76 / 78	86 / 86 / 87	80 / 80 / 81	76 / 76 / 78	
	Heating (SH / H / L)	61 / 61 / 63	50 / 50 / 53	45 / 45 / 50	61 / 61 / 63	50 / 50 / 53	45 / 45 / 50	
Enthalpy Exchange Efficiency	Cooling (SH / H / L)	76 / 76 / 77	67 / 67 / 69	64 / 64 / 66	76 / 76 / 77	67 / 67 / 69	64 / 64 / 66	
	Heating (SH / H / L)	-	-	-	-	-	-	
Operation Range	Outdoor air Temperature	-15 ~ 45	-15 ~ 45	-15 ~ 45	-15 ~ 45	-15 ~ 45	-15 ~ 45	
	Heat Exchange Mode (SH / H / L)	CMH	500 / 500 / 440	800 / 800 / 640	1,000 / 1,000 / 820	500 / 500 / 440	800 / 800 / 640	1,000 / 1,000 / 820
Air Flow Rate	Heat Exchange Mode (SH / H / L)	CMH	500 / 500 / 440	800 / 800 / 640	1,000 / 1,000 / 820	500 / 500 / 440	800 / 800 / 640	1,000 / 1,000 / 820
	Bypass Mode (SH / H / L)	CMH	500 / 500 / 440	800 / 800 / 640	1,000 / 1,000 / 820	500 / 500 / 440	800 / 800 / 640	1,000 / 1,000 / 820
Fan	External Static Pressure (SH / H / L)	Pa	160 / 120 / 100	140 / 90 / 70	110 / 70 / 60	180 / 150 / 110	170 / 120 / 80	150 / 100 / 70
	System	Natural Evaporating Type						-
Humidifier	Amount	kg/h	2.70	4.00	5.40	-	-	
	Pressure Feed Water	Mpa	0.02 ~ 0.49				-	-
Sound Pressure	Heat Exchange Mode (SH / H / L)	dB (A)	38 / 36 / 33	39 / 37 / 34	40 / 38 / 35	39 / 37 / 35	41 / 38 / 36	41 / 39 / 36
	Bypass Mode (SH / H / L)	dB (A)	39 / 37 / 34	40 / 38 / 35	40 / 38 / 35	39 / 37 / 35	41 / 38 / 36	41 / 39 / 36
Refrigerant	R410A							
Power Supply	Ø / V / Hz	1 / 220-240 / 50, 60						
Power Input (Nominal)	Heat Exchange Mode (SH / H / L)	kW	0.25 / 0.20 / 0.15	0.42 / 0.35 / 0.25	0.48 / 0.42 / 0.27	0.25 / 0.20 / 0.15	0.42 / 0.35 / 0.25	0.48 / 0.42 / 0.27
	Bypass Mode (SH / H / L)	kW	0.25 / 0.20 / 0.15	0.42 / 0.35 / 0.25	0.48 / 0.42 / 0.27	0.25 / 0.20 / 0.15	0.42 / 0.35 / 0.25	0.48 / 0.42 / 0.27
Nominal Running Current (RLA)	Heat Exchange Mode (SH / H / L)	A	1.5 / 1.3 / 1.0	2.5 / 2.0 / 1.5	3.6 / 3.2 / 2.3	1.5 / 1.3 / 1.0	2.5 / 2.0 / 1.5	3.6 / 3.2 / 2.3
	Bypass Mode (SH / H / L)	A	1.5 / 1.3 / 1.0	2.5 / 2.0 / 1.5	3.6 / 3.2 / 2.3	1.5 / 1.3 / 1.0	2.5 / 2.0 / 1.5	3.6 / 3.2 / 2.3
Heat exchange system	Air to air cross flow total heat (sensible + latent heat) exchange						Air to air cross flow total heat (sensible + latent heat) exchange	
Heat exchange element	Specially processed non-flammable paper						Specially processed non-flammable paper	
Air Filter	Multidirectional fibrous fleeces						Multidirectional fibrous fleeces	
Dimensions	W x H x D	1,667 x 365 x 1,140				1,667 x 365 x 1,140		
Net Weight		kg	105				98	
	Liquid	mm	Ø6.35				Ø6.35	
Piping Connection	Gas	mm	Ø12.7				Ø12.7	
	Water	mm	Ø6.35				-	
Connection Duct Diameter	Drain Pipe (Internal Dia.)	mm (inch)	Ø25 (1)				Ø25 (1)	
		mm	Ø250				Ø250	

- Note : 1. Cooling Capacity Test condition - Indoor temperature : 27°C DB, 19°C WB / Outdoor temperature : 35°C DB
- 2. Heating Capacity Test condition - Indoor temperature : 20°C DB / Outdoor temperature : 7°C DB, 6°C WB
- 3. Humidifying capacity is based on the following conditions - Indoor temperature : 20°C DB, 15°C WB / Outdoor temperature : 7°C DB, 6°C WB
- 4. Cooling and heating capacities are based on the following conditions. : Fan is based on High and Super-high.
- 5. The operating sound measured at the point 1.5 m below the center of the unit is converted to that measured at an anechoic chamber.
- 6. The specifications, designs and information here are subject to change without notice.

Accessories

Chassis	LZ-H050GXH4	LZ-H080GXH4	LZ-H100GXH4	LZ-H050GXN4	LZ-H080GXN4	LZ-H100GXN4
Drain Pump	-	-	-	-	-	-
Cassette Cover	-	-	-	-	-	-
Refrigerant Leakage Detector	-	-	-	PRLDNV50	-	-
EEV Kit	-	-	-	-	-	-
Independent Power Module	-	-	-	-	-	-
Robot Cleaner	-	-	-	-	-	-
Pre Filter (washable / anti-fungus)	-	-	-	-	-	-
Ion Generator	-	-	-	-	-	-
CO ₂ Sensor	-	-	-	AHCS100H0	-	-
Ventilation Kit	-	-	-	-	-	-
IR Receiver	-	-	-	-	-	-
Zone Controller	-	-	-	-	-	-
Dry Contact (with additional accessory)	-	-	-	PDRYCB000 (1 point contact)	PDRYCB500 (Modbus)	-
External Input (1 point)	-	-	-	○	-	-
Wi-Fi	-	-	-	-	-	-

















※ ○ : Applied, - : Not applied
Option : Refer to model name in table

CONTROL SOLUTIONS

















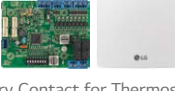

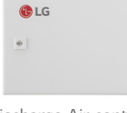



—
INDIVIDUAL CONTROL / CENTRALIZED CONTROL
INTEGRATION DEVICE



LG HVAC CONTROL LINE-UP

INDIVIDUAL CONTROL		CENTRALIZED CONTROL			
Wired Remote Controller		Wireless Remote Controller	Display	Platform	Gateway
Standard	Simple				
Standard III (White)  PREMTB100	 PQRCVCLQW	 PQWRHQ0FDB	AC Ez  PQCSZ250S0 (Indoor Unit ~32)	ACP 5  PAC5A000 (Indoor Unit ~256)	 ACP Lonworks PLNWKB000 (Indoor Unit ~64)
		Wi-Fi Controller			
Standard III (Black)  PREMTBB10	 PQRCVCLQQ	LG Wi-Fi Modem  For Indoor Unit PWFMD200	AC Ez Touch  PACEZA000 (Indoor Unit ~64)	AC Manager 5  PACM5A000 (Indoor Unit ~8,192)	Modbus RTU Gateway  PMBUSB00A
Standard II (White)  PREMTB001	 PQRCHCA0QW (Simple for Hotel)				
Standard II (Black)  PREMTBB01	 PQRCHCA0Q (Simple for Hotel)				
Premium					
 PREMTA000 PREMTA000A PREMTA000B					

Note
 1. AC Smart 5 & ACP 5 provides BACnet IP / Modbus TCP
 2. KNX Gateway is provided by INTESIS

CENTRALIZED CONTROL	INTEGRATION DEVICE				
	Facility Integrator	Indoor Unit		Outdoor Unit	AHU Kit
		Dry Contact	Control Accessory		
PDI (Power Distribution Indicator)  Premium (8 port) PQNUD1S40 Standard (2 port) PPWRDB000	 Simple Dry Contact PDRYCB000	 PZCWRCG3	IO Module (Input / Output Module)  For MULTI V 5 PVDSMN000	Communication Kit  Return/Room Air control PAHCMR000	
ACS IO Module (Input / Output Module)  PEXPMB000	 Dry Contact for Thermostat PDRYCB300	Remote Temperature Sensor  PQRSTA0	Variable Water Flow Control kit  For MULTI V WATER IV PWFCN000	 Discharge Air control PAHCM5000	
Chiller Option Kit  PCHILLN000	 2 Points Dry Contact (For Setback) PDRYCB400	Low Profile Remote Temperature Button Sensor  ZRTBS01	Low Ambient Kit  For MULTI V IV, 5 PRVC2	Control kit  PRCKD21E (- 4 ODU) PRCKD41E (- 8 ODU)	
ACU IO Module  PEXPM300	 For Modbus PDRYCB500	Zone Controller  4 Zones by thermostat ABZCA	Cool / Heat Selector  PRDSBM	EEV Kit (Electronic Expansion Valve)  PRLK048A0 (- 10HP) PRLK096A0 (- 20HP)	
 PEXPM200					
 PEXPM100					
			TXV Kit (Thermal Expansion Valve)  PATX13A0E (8 - 16HP) PATX20A0E (18 - 26HP) PATX25A0E (28 - 36 HP) PATX35A0E (38 - 46 HP) PATX50A0E (48 - 56 HP)		

LG CONTROL SOLUTIONS







MULTI V 5 offers a diverse range of effective control solutions that satisfy specific needs of each building and its user scene. These controlling systems are equipped with user friendly interface, flexible interlocking environment, energy management and smart individual controller for optimized controlling conditions and smart building management.



INDIVIDUAL CONTROL



FEATURE FUNCTIONS

Controller Name	Wired Remote Controller					Wireless Remote Controller	Wi-Fi Controller
	Premium	Standard III	Standard II	Simple	Simple(Hotel)		
Model Name							
	PREMTA000 PREMTA000A PREMTA000B	PREMTB100 PREMTBB10	PREMTB001 PREMTBB01	PQRCVCL0Q PQRCVCL0QW	PQRCHCA0Q PQRCHCA0QW	PQWRHQ0FDB	PWFMD200
Basic							
On / Off	○	○	○	○	○	○	○
Fan Speed Control	○	○	○	○	○	○	○
Temperature Setting	○	○	○	○	○	○	○
Mode Change	○	○	○	○	-	○	○
Auto Swing	○	○	○	○	○	○	○
Vane Control (Louver Angle)	○	○	○	○	○	○	○
E.S.P (External Static Pressure)	○	○	○	○	○	-	-
Electric Failure Compensation	○	○	○	○	○	-	○
Indoor Temperature Display	○	○	○	○	○	○	-
ALL Button Lock (Child Lock)	○	○	○	○	○	-	-
Advanced							
Schedule / Timer	Weekly-Yearly	Weekly-Yearly	Weekly	-	-	Sleep / On / Off	Weekly
Additional Mode Setting ¹⁾	○	○	○	-	-	-	-
Time Display	○	○	○	-	-	○	-
Humid. Display	○	○	-	-	-	-	-
Advanced Lock (mode, set point, set point range, On / Off Lock)	Advanced Lock	Advanced Lock	Mode Lock	-	-	-	-
Filter Sign	○	○	○	-	-	-	-
Energy Management ²⁾	○	○	○	-	-	-	-
Dual Set Point	○	○	-	-	-	-	-
Human Detection	-	○	-	-	-	-	-
Temp, Humidity Compensation	○	○	-	-	-	-	-
Wi-Fi AP Mode Setting	○	○	○	○	○	○	-
Operation Status LED	○	○	○	○	○	-	-
Wireless Remote Controller Receiver	○ ³⁾	-	○ ³⁾	○ ³⁾	○ ³⁾	-	-
ETC							
Display	5 inch Color	4.3 inch Color	4.3 inch mono	2.6 inch mono	2.6 inch mono	2 inch mono	-
Size (W x H x D, mm)	137 x 121 x 16.5	120 x 120 x 16	120 x 120 x 16	64 x 120 x 15	64 x 120 x 15	51 x 153 x 26	-
Black Light Control for Screen Saver	○	○	-	-	-	-	-

※ ○ : Applied, - : Not Applied

1) It might not be indicated or operated at the partial product

2) Centralized control (PACEZA000 / PACS5A000 / PACP5A000 / PLNWK000) and PDI (PQNUD1S40 / PPWRDB000) should be installed for this function

3) For ceiling type duct

Note : 1. Indoor unit should have functions requested by the controller

2. If you need more detail, please refer to the manual of product. (<http://partner.lge.com>: Home> Doc.Library> Manual)

OUTDOOR UNITS

INDOOR UNITS

HOT WATER SOLUTION

VENTILATION SOLUTIONS

CONTROL SOLUTIONS

ACCESSORIES

STANDARD III WIRED REMOTE CONTROLLER

4.3 inch Color screen with a modern design.



PREMTB100 (White) PREMTBB10 (Black)

- The Optimized Controller in MULTI V 5
 - Humidity sensor embedded
 - Comfort cooling setting
 - Smart Load Control setting
 - Outdoor unit low noise setting
 - Defrost mode setting
- New Modern Design & Easy Interface
 - Seamless design / Touch button
 - 4.3 inch color LCD / Intuitive GUI
- Energy Saving Functions
 - Instantaneous power monitor
 - Energy consumption check (power consumption, operation time)
 - Temp. Setback Timer, Time Limit Control
 - Target setting (ODU Capacity, Instantaneous power-etc)
- Group Control
 - Up to 16 Indoor units can be controlled with one remote control
- External Device On / Off (1 point)
 - Customized interlocking control with indoor unit is possible without dry contact
- 2 Set Points Control
 - Increase convenience and comfort
 - Auto changeover, Setback (home leave)

Model Name	PREMTB100 / PREMTBB10
On / Off	○
Fan Speed Control	○
Temperature Setting	○
Mode Change	Cooling / Heating / Auto / Dehumidification / Fan
Additional Mode Setting ¹⁾	Energy-Saving Cooling / Robot Cleaning / Heater / Humidification / Comfort Cooling
Auto Swing	○
Vane Control (Louver direction)	○
E.S.P (External Static Pressure) ²⁾	○
Reservation	Simple / Sleep / On & Off timer / Weekly / Yearly / Holiday
Time Display	○
Electric Failure Compensation	○
Lock	All / On & Off / Mode / Set temperature range
Filter Sign	○ (Remain time + Alarm)
Energy Management	Check Energy Usage ³⁾ / Check Operation Time / Target Setting (Energy, Operation Time) / Time Limit Operation / Alarm Popup / Initialization Usage Data
Operation Status LED	○
Indoor Temperature Display	○
Indoor Humidity Display	○
Display	4.3 inch TFT color LCD (480 x 272)
Size (W x H x D, mm)	120 x 120 x 16
Black light for Screen saver	○
Home Leave	2 set points control

※ ○ : Applied, - : Not Applied
 1) It might not be indicated or operated at the partial product
 2) This function is available for duct type
 3) This function requires PDI (PQNUD1S40 / PPWRDB000) to be installed.
 Note : 1. Indoor unit needs to have functions requested by the controller
 2. 2 set points control works normally with MULTI V Heat Recovery and Single Split Heat Pump. But in case of MULTI V Heat Pump, It may not work properly

Energy Saving Function

Energy Management

- Energy Monitoring & Alarm
- Real-time and day / week / month / year energy usage monitoring is possible. In addition, it can set target for energy usage and operation time, and alarm will be displayed when exceeded.
- * PDI (PQNUD1S40 / PPWRDB000) is required.

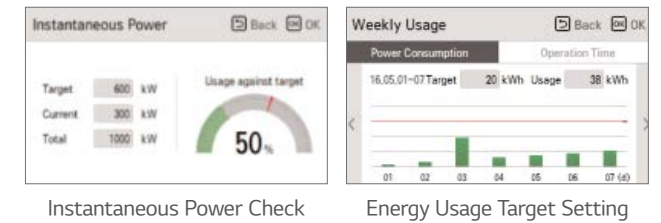

Time Limit Control

- The time-limit operation is to limit the amount of time.
- By setting the device operation time in advance, you can control for how long a device works and have it stop automatically.



2 Set Points Control

Auto Changeover (Convenience)

- The indoor unit automatically manages room temperature with heating and cooling with extended setting temperature ranges.
- With setting heating and cooling set temp. just one time, comfortable condition will continue at all times.

Setback (Home Leave) (Energy saving & Comfort)

- In the absence, room temperature can be kept in the range of 2 set points instead of power off. It provides comfortable indoor environment quickly when the mode is changed to occupied.

* This function is for Heat Recovery system or Single heat pump. Otherwise it is not guaranteed.

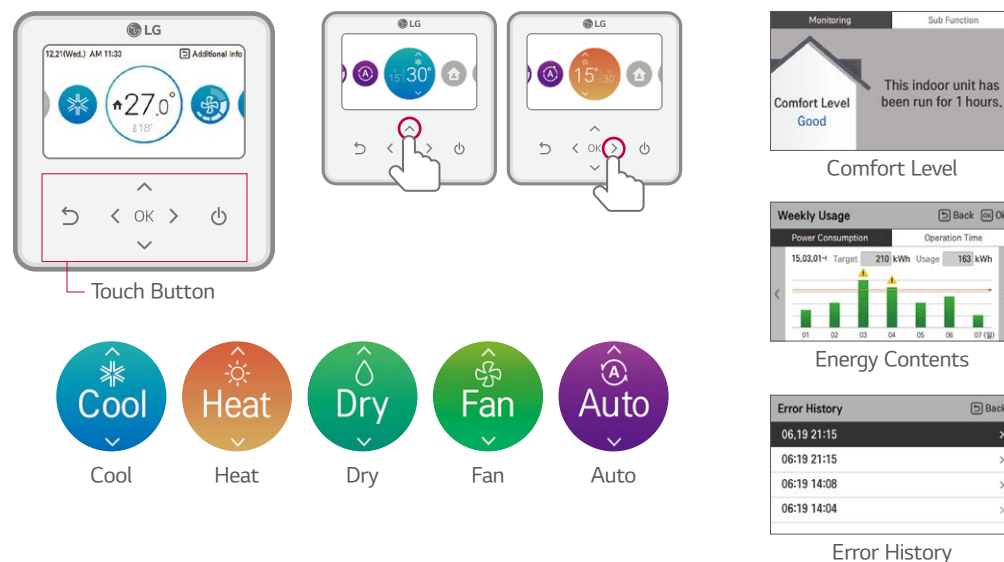
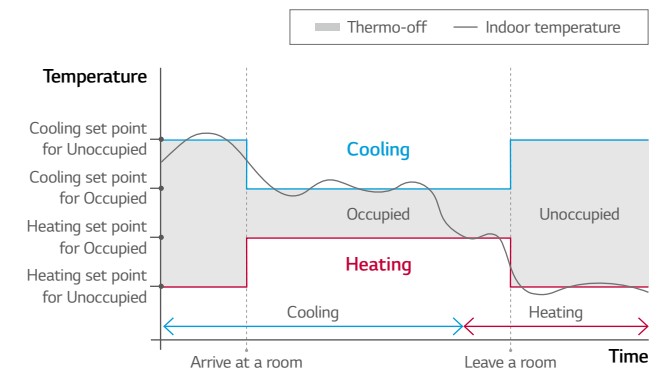

External Device On / Off

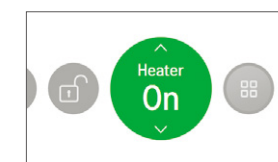

External Equipment Control
 User can turn on or off the external equipment through contact point output.

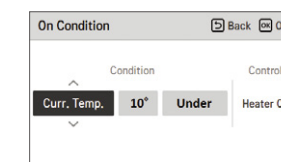

Customized Interlocking Control
 User can make control scenario. example) When temperature is under 10 degree, turn on the external heater.

Schedule Function



Easy Checking Schedule
 Standard III remote controller provides clock type daily schedule.

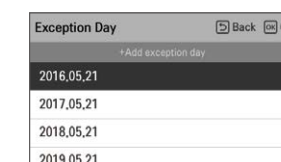

Exception Day settings
 Convenient settings are possible with schedule exception settings.

PREMIUM WIRED REMOTE CONTROLLER

5 inch full touch screen with a premium design.



PREMTA000 ¹⁾ / PREMTA000A ²⁾ / PREMTA000B ³⁾

1) English / Portuguese / Spanish / French
2) English / Italian / Russian / Chinese
3) English / German / Polish / Czech

Features & Benefit

- Full Touch screen
- The Optimized Controller in MULTI V 5
 - Comfort cooling setting
 - Smart Load Control setting
 - Outdoor unit low noise setting
 - Defrost mode setting
- Design with User's Convenience
 - Intuitive GUI
 - Main display simple mode
 - 5 inch color LCD
- Energy Saving Functions
 - Instantaneous power monitor
 - Energy consumption check (power consumption, operation time)
 - Temp. Setback Timer, Time Limit Control
 - Target setting (ODU Capacity, Instantaneous power-etc)
- Group Control
 - Up to 16 Indoor units can be controlled with one remote control
- 2 Set Points Control
 - Increase convenience and comfort
 - Auto changeover, Setback (home leave)

Model Name	PREMTA000 / PREMTA000A / PREMTA000B
On / Off	○
Fan Speed Control	○
Temperature Setting	○
Mode Change	Cooling / Heating / Auto / Dehumidification / Fan
Additional Mode Setting ¹⁾	Energy-Saving Cooling / Robot Cleaning / Heater / Humidification
Auto Swing	○
Vane Control (Louver direction)	○
E.S.P (External Static Pressure) ²⁾	○
Reservation	Simple / Sleep / On / Off / Weekly / Yearly / Holiday
Time Display	○
Electric Failure Compensation	○
Child Lock	○
Filter Sign	○ (Remain time + Alarm)
Energy Management	Check Energy Usage ³⁾ / Check Operation Time / Target Setting (Energy, Operation Time) / Time Limit Operation / Alarm Popup / Initialization Usage Data
Operation Status LED	○
Indoor Temperature Display	○
Wireless Remote Controller Receiver	○ ⁴⁾
Display	5 inch TFT color LCD (480 x 272)
Size (W x H x D, mm)	137 x 121 x 16.5
Black Light for Screen Saver	○
Home Leave	2 set points control

※ ○ : Applied, - : Not Applied
1) It might not be indicated or operated at the partial product
2) This function is available for duct type
3) This function requires PDI (PQNUD1S40 / PPWRDB000) to be installed.
4) For ceiling type ducted unit
Note : 1. Indoor unit needs to have functions requested by the controller
2. 2 set points control works normally with MULT V Heat Recovery and Single Split Heat Pump. But in case of MULTI V Heat Pump, It may not work properly



Easy Energy Management

- Check the operation hour or electricity usage
- Comparison of usage compared to last year
- Set the target usage and time



Easy Scheduling

- Daily, Weekly, Yearly schedule function
- Schedule pattern setting
- Schedule copy



2 Set points Control

- Auto changeover switching the operation mode automatically
 - Setback (Home Leave) Changing status by occupied / unoccupied
- * This function is only for Heat Recovery system and Single heat pump.

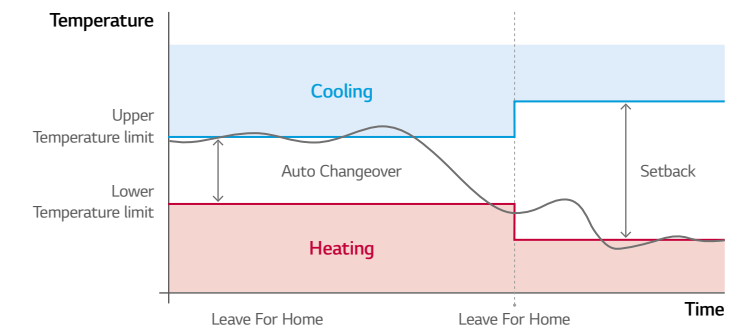

Group Control

1. Max. 16 Indoor units by one remote controller.

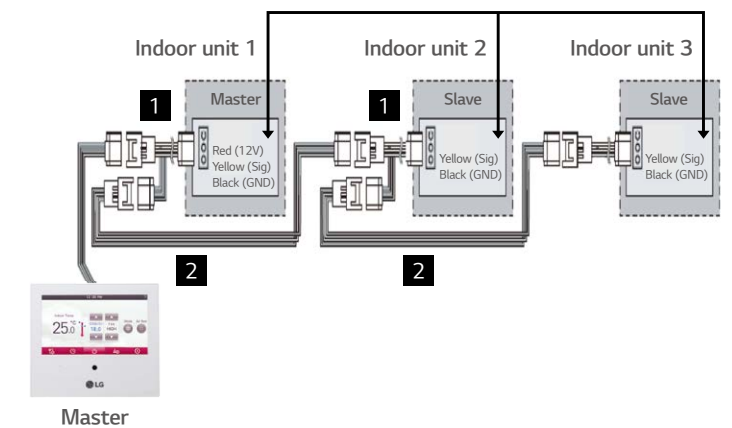

STANDARD II WIRED REMOTE CONTROLLER

Providing easy control of one or a group of indoor units with various functions.



PREMTB001 (White)



PREMTBB01 (Black)

Model Name	PREMTB001 / PREMTBB01
On / Off	○
Fan Speed Control	○
Temperature Setting	○
Mode Change	Cooling / Heating / Auto / Dehumidification / Fan
Additional Mode Setting	Energy-Saving Cooling / Robot Cleaning / Heater / Humidification
Auto Swing	○
Vane Control (Louver direction)	○
E.S.P (External Static Pressure)	○
Reservation	Simple / Sleep / On / Off / Weekly / Holiday
Time Display	○
Electric Failure Compensation	○
Child Lock	○
Filter Sign	○ (Remain time + Alarm)
Operation Status LED	○
Indoor Temperature Display	○
Wireless Remote Controller Receiver	○ ¹⁾
Size (W x H x D, mm)	120 x 120 x 16
Blacklight	○
Power Consumption Monitoring	○ ²⁾
Check Model Information	○

※ ○ : Applied, - : Not Applied
 1) For ceiling type ducted unit.
 2) This function requires PDI (PQNUD1S40 / PPWRDB000) to be installed.
 Note : Indoor unit needs to have functions requested by the controller

Features & Benefit

- Wired remote controller that can implement various functions such as schedule, filter sign.

SIMPLE WIRED REMOTE CONTROLLER

A simple way to control office or hotel systems in a compact design



PQRCVCL0QW (White) / PQRCVCL0Q (Black)



PQRCHCA0QW (White) / PQRCHCA0Q (Black)

Model Name	PQRCVCL0QW / PQRCVCL0Q	PQRCHCA0QW / PQRCHCA0Q
On / Off	○	○
Fan Speed Control	○	○
Temperature Setting	○	○
Mode Change	Cooling / Heating / Auto / Dehumidification / Fan	Only Changeable by Central Controller
Auto Swing	○	-
Vane Control (Louver direction)	○	-
E.S.P (External Static Pressure)	○	○
Electric Failure Compensation	○	○
Child Lock	○	○
Indoor Temperature Display	○	○
Wireless Remote Controller Receiver	○ ¹⁾	○ ¹⁾
Size (W x H x D, mm)	70 x 121 x 16	70 x 121 x 16
Blacklight	○	○

※ ○ : Applied, - : Not Applied
 1) For ceiling type ducted unit
 Note : Indoor unit needs to have functions requested by the controller

Features & Benefit

- Small remote control with minimal functionality

WIRELESS REMOTE CONTROLLER



PQWRHQ0FDB

Features & Benefit

- Easy to use while moving
- Main functions are available

Model Name	PQWRHQ0FDB
On / Off	○
Fan Speed Control	○
Temperature Setting	○
Mode Change	Cooling / Heating / Auto / Dehumidification / Fan
Additional Mode Setting	Plasma Purification / Energy-Saving Cooling / Robot Cleaning / Auto Dry
Auto Swing	○
Vane Control (Louver direction)	○
Reservation	Sleep / On / Off
Indoor Temperature Display	○
Sleep Mode Auto	Max. 7 hours
Size (W x H x D, mm)	51.4 x 153 x 26

※ ○ : Applied, - : Not Applied

LG Wi-Fi MODEM

Control LG air conditioners via using the internet devices as Android or iOS smartphones.



PWFMD200

Model Name	PWFMD200
Size (W x H x D, mm)	48 x 68 x 14
Interfaceable Products	MULTI V Indoor unit ³⁾
Connection Type	Indoor unit 1:1
Communication Frequency	2.4 GHz
Wireless Standards	IEEE 802.11b/g/n
Mobile Application	LG SmartThinQ (Android v4.1(Jellybean) or higher, iPhone iOS 9.0 or higher)
Optional Extension Cable	PWYREW000 (10m extension)

1) Vane Control may not be possible according to the type of Indoor unit
 2) LG Centralized controller and PDI installation is required for this function
 3) For the compatibility with Indoor unit, please contact regional LG office
 Note : 1. Functionality may be different according to each IDU model
 2. User interface of application shall be revised for its design and contents improvement
 3. Application is optimized for smartphone use, so it may not be well functioning with tablet devices

Features & Benefit

- Access LG air conditioner anytime and from anywhere with Wi-Fi equipped device.
- It is possible to check whether the air conditioner is turned off when the user goes out (energy saving), and can be operated in advance before entering the house (comfort improvement).
- LG's exclusive Home Appliances control app(SmartThinQ) is available
- Simple operation for various functions
 - On / Off
 - Operation Mode
 - Current/Set Temperature
 - Fan Speed
 - Vane Control¹⁾
 - Reservation (Sleep, Weekly On / Off)
 - Energy Monitoring²⁾
 - Filter Management
 - Error Check

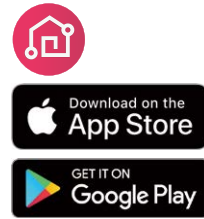
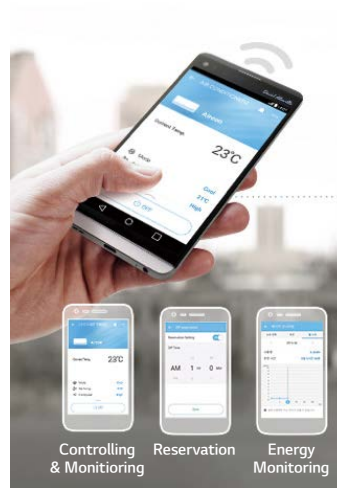

Overview

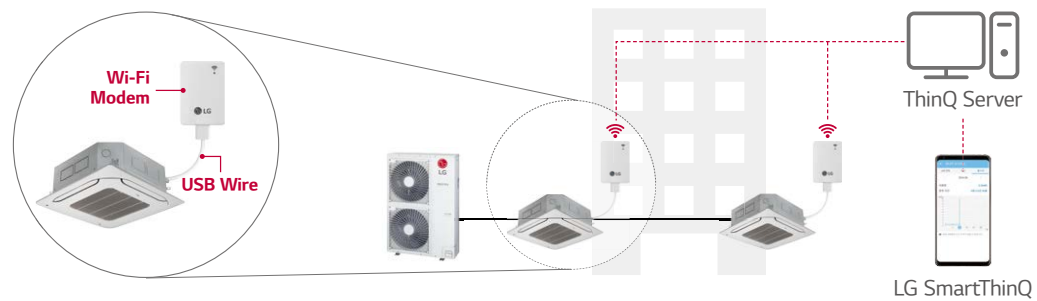

* Search "LG SmartThinQ" on Google market or Appstore then download the app. * Internet service with Wi-Fi connection has to be available.

Installation Scene

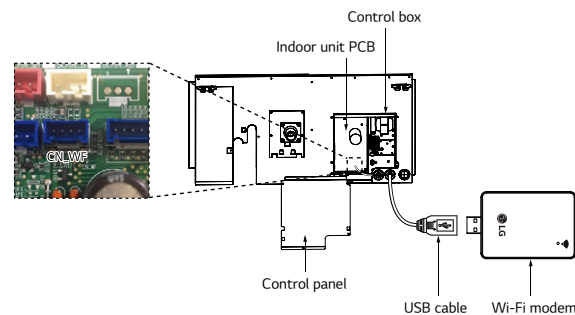

* Each indoor unit has a Wifi modem installation location inside the product, and it can be installed by exposure if necessary.

Connected Diagram

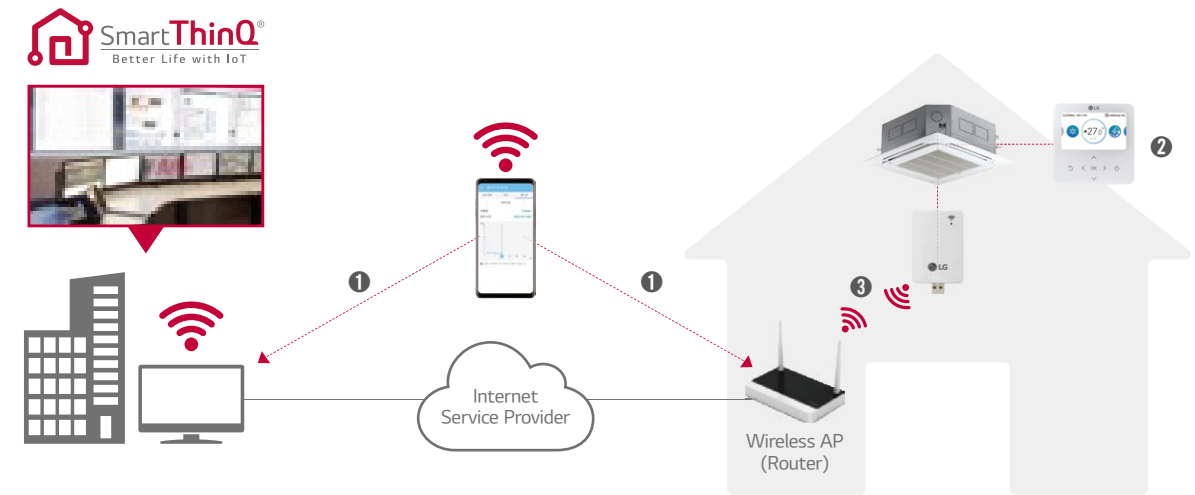

Connection (Pairing) Order

- 1 Make LG account on LG Smart ThinQ and select the Router that will use
- 2 Insert passwords of selected router and do set AP by LG remote controller
- 3 Confirm the pairing between Wi-Fi Modem and Router

Smart ThinQ

Simple operation for various functions

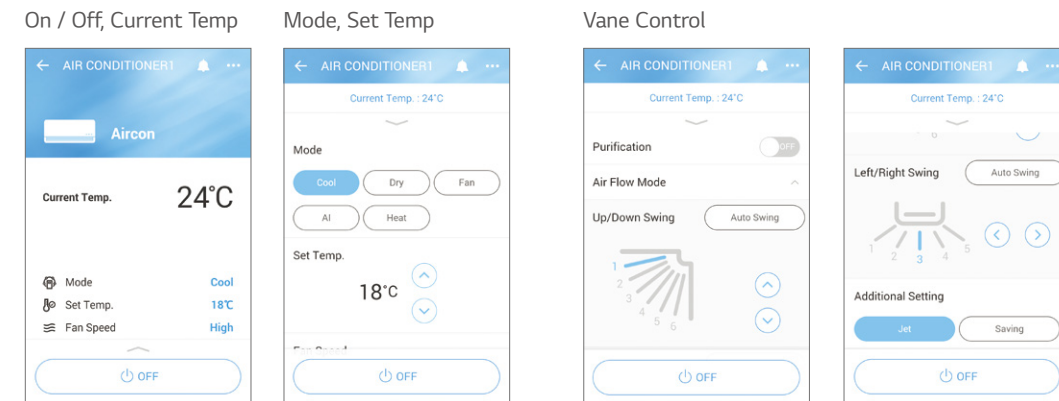



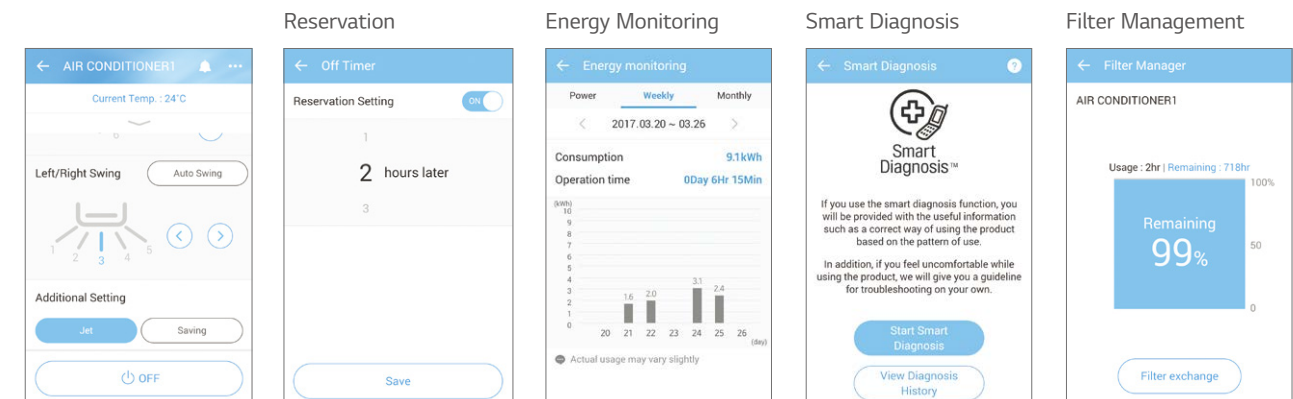



Straight forward Management



CENTRALIZED CONTROL

CENTRALIZED CONTROLLER FEATURE LIST

Controller Name		AC Ez	AC Ez Touch	AC Smart 5 ⁵⁾	ACP 5 ⁵⁾	ACP Lonworks	AC Manager 5 ³⁾
Model Name							
		PQCSZ250S0	PACEZA000	PAC55A000	PACP5A000	PLNWKB000	PACM5A000
Product	DO	-	-	2	4	2	-
	DI	-	1	2	10	2	-
	IDUs	32	64	128	256	64	8,192
	Max. Connectable No.	32	64	128	256	64	-
	A/C + ERV	32	64	128	256	64	-
	AHU	-	-	16	16	16 ⁴⁾	-
Compatibility	Chiller	-	-	5 Optional ²⁾	10 Optional ²⁾	-	-
	Air Conditioner	○ ¹⁾	○	○	○	○	○
	Ventilation (ERV / ERV DX)	○ ²⁾	○	○	○	○	○
	Heating	-	○	○	○	○	○
	AHU	-	-	○	○	○	○
	Chiller	-	-	○ ⁴⁾	○ ⁴⁾	-	○
Additional Function	ACS IO	-	-	○ ⁴⁾	○ ⁴⁾	○ ⁴⁾	○
	Add Drawing	-	-	○ ⁴⁾	○ ⁴⁾	○ ⁴⁾	○
	Group Management	-	-	○ ⁴⁾	○ ⁴⁾	○ ⁴⁾	○
	Auto Changer Over	-	○	○ ⁴⁾	○ ⁴⁾	○ ⁴⁾	○
	Set Back	-	○	○ ⁴⁾	○ ⁴⁾	○ ⁴⁾	○
	2 Set	-	○	○	○	○ ⁴⁾	-
	Change Alarm	-	Filter	Filter	Filter	Filter	Filter
	Indoor Unit Lock	-	○	○	○	○ ⁴⁾	-
	Cycle	-	-	○	○	○ ⁴⁾	○
	Schedule	○	○	○ ⁴⁾	○ ⁴⁾	○ ⁴⁾	○
Auto Control	Peak Control	-	○	○	○	○ ⁴⁾	○
	Outdoor Unit Capacity Control	-	-	○ ⁴⁾	○ ⁴⁾	○ ⁴⁾	○
	Demand Control	-	-	-	-	○ ⁴⁾	○
	Outdoor Unit Capacity Control	-	-	-	-	○ ⁴⁾	○
	Time limit control	-	-	○ ⁴⁾	○ ⁴⁾	○ ⁴⁾	○
	InterLocking	-	-	○ ⁴⁾	○ ⁴⁾	○ ⁴⁾	○
Energy Report	Energy Navigation	-	-	○ ⁴⁾	○ ⁴⁾	-	○
	Power	-	○	○	○	○ ⁴⁾	○
	Gas	-	-	○	○	○ ⁴⁾	○
	Run time	-	-	○ ⁴⁾	○ ⁴⁾	○ ⁴⁾	○
	Email	-	-	○ ⁴⁾	○ ⁴⁾	○ ⁴⁾	-
Trend Reporting	PC / USB	-	-	○ ⁴⁾	PC	PC	PC
	History	-	-	-	-	-	○
	Report (Control / Error)	-	Error	○ ⁴⁾	○ ⁴⁾	○ ⁴⁾	○
etc	Send Email	-	-	○ ⁴⁾	○ ⁴⁾	○ ⁴⁾	○
	Save to PC / USB	-	-	○ ⁴⁾	○ ⁴⁾	○ ⁴⁾	PC
	Summer Time	-	○	○ ⁴⁾	○ ⁴⁾	○ ⁴⁾	-
etc	Outdoor Unit Oil-Return Operation	-	-	○ ⁴⁾	○ ⁴⁾	○ ⁴⁾	-
	User Authority	-	Password	○ ⁴⁾	○ ⁴⁾	○ ⁴⁾	○
	PC Access	-	○	○ ⁴⁾	○ ⁴⁾	○ ⁴⁾	○

※ ○ : Applied, - : Not Applied
 1) Except for some feature (individual lock, limit, temp., etc.)
 2) Except for some feature (user mode, additional function, etc.)
 3) ACP 5 or AC Smart 5 is required
 4) This function is possible to use in Web Only (BMS Point is not applied)
 5) Without additional device, ACP 5 and AC Smart 5 provide BACnet IP and Modbus TCP interface for BMS

OUTDOOR UNITS

INDOOR UNITS

HOT WATER SOLUTION

VENTILATION SOLUTIONS

CONTROL SOLUTIONS

ACCESSORIES

AC EZ TOUCH

Smart management with 5 inch touch screen for small site.



PACEZA000

Model Name	PACEZA000
Size (W x H x D, mm)	137 x 121 x 25
Interfaceable Products	MULTI V / ERV / ERV DX / Hydro kit / THERMA V
Maximum number of units	64
Individual / Group Control	On & Off / Mode / Temperature / Fan speed
Individual Controller Lock	Temperature / Mode / Fan speed / All
Error Check	○
Slave Mode (Interlocking with higher level controller)	○
Schedule	Weekly / Monthly / Yearly / Exception day
Remote Access	By client S/W
Emergency Stop & Alarm Display	○
Power Consumption Monitoring (with PDI)	○
Auto Changeover / Setback	○
Temperature Limit	○
Operation History	Error record
ODU Low Noise 1)	○
Daylight Saving Time	○
External IO Port	DI 1
IPv6 Support	○

※ ○ : Applied, - : Not Applied
1) It is only available in some products

Features & Benefit

- Remote Access with Graphical User Access Control
- Total 200 Schedule Events
- Energy saving mode
- Energy Monitoring (with PDI)
- 2 Set point function (Upper/Lower Temperature setting)
- Temperature Set points Range Limit
- Remote Controller Lock (All, Temp, Mode, Fan Speed)
- Operation History
- Change alarm (Filter change)
- Emergency stop

Overview



Feature

PC Access

Users can control each space efficiently through PC access.



Energy Statistics (with PDI)

Statistics of operational status (time, power consumption) are provided to help make intelligent system operation decisions.

Energy		
2016. 2. 8 ~ 2016. 3. 19		
	Today	Week
Name	Usage(kWh)	Accumulated(kWh)
Group1	110	3021
Group2	150	6186
Group3	130	4267
Group4	120	7614

Energy Mode

When using energy mode function, operation mode changes from cooling to fan or heating to off mode by force. (It is available only 'on' mode indoor unit)

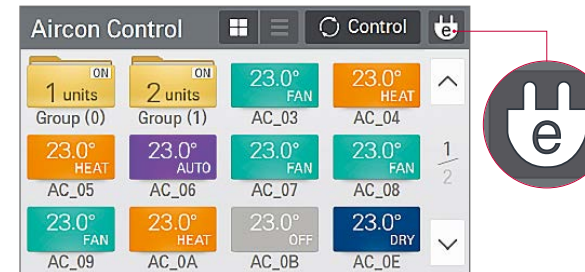

Alarm Indicator

It works when there are some errors or it's time to change the filter. Users can respond immediately according to alarm indicator therefore HVAC system is monitored consistently.

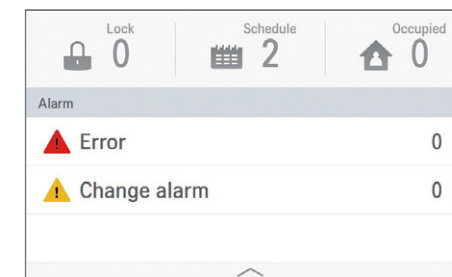

AC EZ

Easy to manage up to 32 indoor units, including ERV with simple interface.



PQCSZ250S0

Model Name	PQCSZ250S0
Size (W x H x D, mm)	190 x 120 x 20
Interfaceable Products	MULTI V / ERV / ERV DX
Display	LED / LCD Display
Power	DC 12V
Maximum number of units	32
Individual / Group Control	On & Off / Mode / Temperature / Fan speed
Individual Controller Lock	All
Error Check	○
Slave Mode (Interlocking with higher level controller)	○
Schedule	Weekly

※ ○ : Applied, - : Not Applied

Features & Benefit

- 32 indoor units control
- Weekly Schedule
- Individual / Group Control

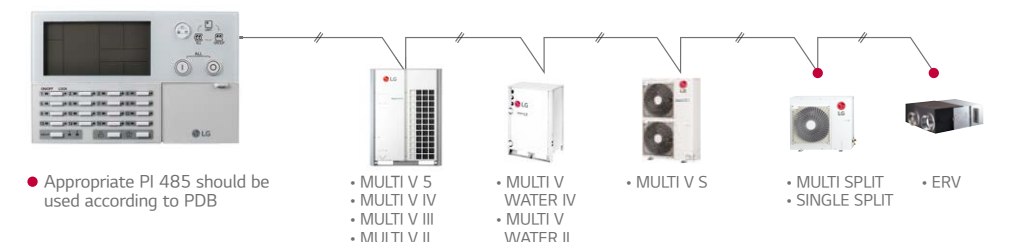

AC SMART 5

Control LG air conditioners via using the internet devices as Android or iOS bases smartphones.



PAC55A000

Features & Benefit

- The central controller allows control of the LG HVAC system to various platforms. (Touch screen, PC, Smartphone, Tablet)
 - DI : 2 / DO : 2
 - Max. 128 IDU control
 - BACnet IP/Modbus TCP
 - Schedule
 - Map View (Visual Navigation)
 - Time limit control / Auto change over
 - Energy monitoring
 - History / Operation Trend
 - Interlock with 3rd party equipment (ACS IO, ACU IO Module is needed)
 - Multi level grouping
 - Emergency stop & alarm
 - Error alarm by E-mail

Model Name	PAC55A000
Size (W x H x D, mm)	253.2 x 167.7 x 28.9
Interfaceable Products	MULTI V / ERV / ERV DX / HYDRO KIT / THERMA V / AHU kit / LG Chiller ¹⁾
Maximum number of units	128
Individual / Group Control	On & Off / Mode / Temperature / Fan speed
Individual Controller Lock	Temperature / Mode / Fan speed / All
Advanced Function Setting and Display ²⁾	Comfort Cooling / ODU Low Noise / ODU Defrost Mode / Comfort Level display / CO ₂ Level display (for ERV / ERV DX) / Night Time Free Cooling (for ERV / ERV DX)
Error Check	○
Slave Mode (Interlocking with higher level controller)	○
Schedule	Weekly / Monthly / Yearly / Exception day
Web Access	○
Emergency Stop & Alarm Display	○
Power Consumption Monitoring (with PDI)	○
Auto Changeover / Setback	○
Temperature Limit	○
Operation Time Limit	○
Visual Navigation	○
Operation Trend	○
Interlock Control	○
Virtual Group Control	○
ODU Capacity Control	○
Energy Navigation (with PDI)	○
Daylight Saving Time	○
External IO Port	DI 2 / DO 2
BMS Integration ³⁾	BACnet IP / Modbus TCP
IPv6 Support	○

※ ○ : Applied, - : Not Applied
 1) Chiller Option Kit (PCHLLN000) is required
 2) It is only available in some products
 3) For the detail point list, please refer to the installation manual

Overview

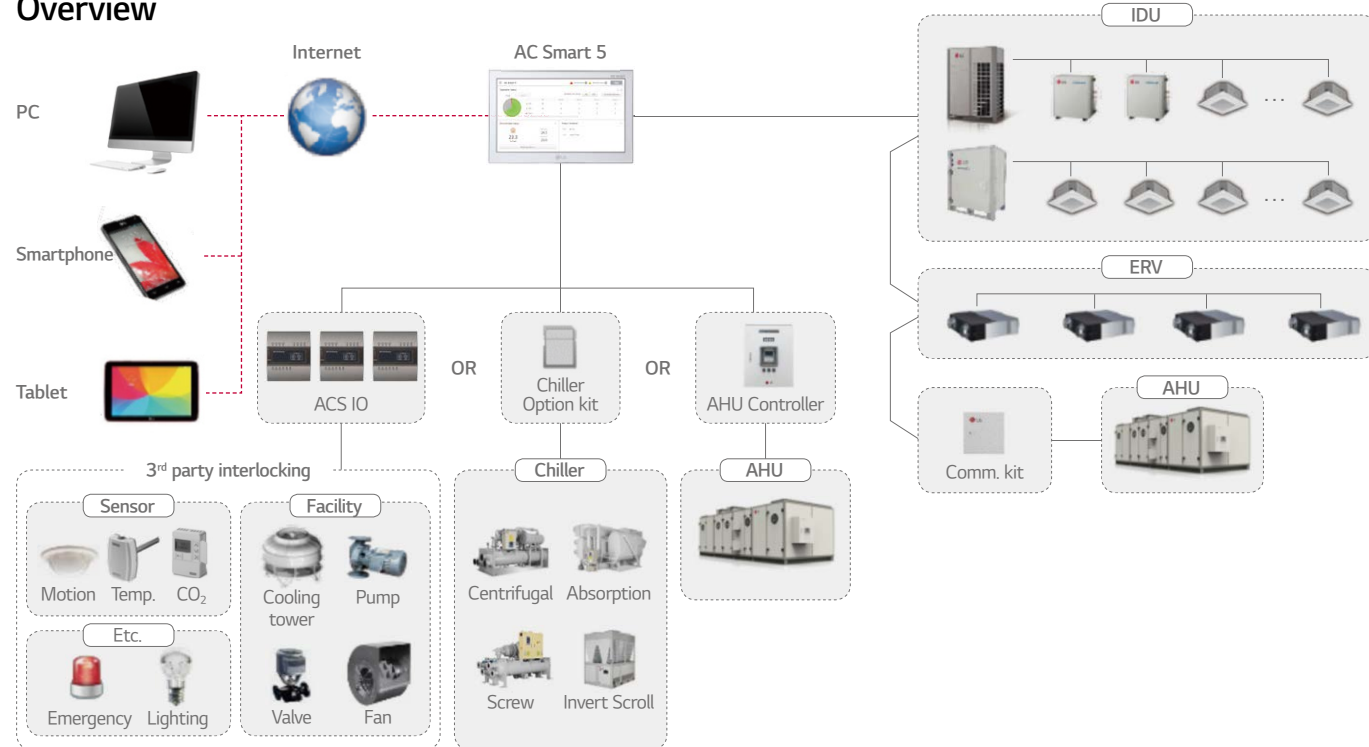

Feature

BMS Integration

Without additional device, AC Smart 5 provides BACnet IP / Modbus TCP interface for BMS (Building Management System) integration as well as its own management function.

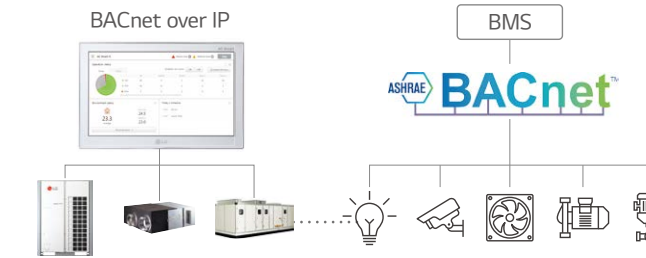

Energy Management / Operation Trend

Energy navigation function allows air conditioners operation to be managed under the monthly (Weekly / Yearly) plan of energy usage. By analyzing present energy consumption and comparing with the plan, overuse of system operational costs can be prevented.

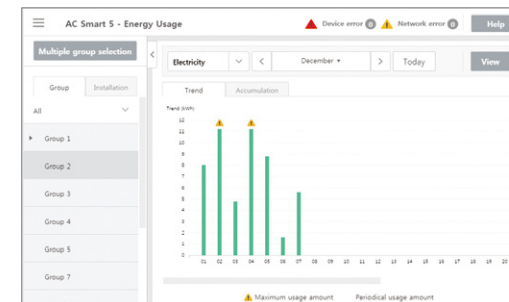

Advanced Network Accessibility

AC Smart 5 reflects the state of the art of network technology trend. IPv6 (Internet Protocol version 6), which is the most recent version of the Internet Protocol, provides accessibility to the IPv6 compatible network environment. In addition, HTML5 allows you to easily control LG HVAC system on a variety of platforms (PC, Mobile, Tablet), at any time and from any location, not just on the touch screen.



Visualized Control

Visual navigation enables controlling and monitoring the unit on floor plan view for the intuitive management.

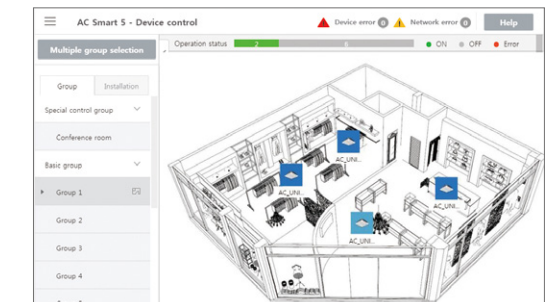

Multi Level Group Composition

You can freely apply layer structure such as building, floor, zone, etc. and set the group as the same as the site composition to control and monitor the devices. Special control group You can additionally compose frequently used groups such as VIP Room, executive room, etc. regardless of the building structure.

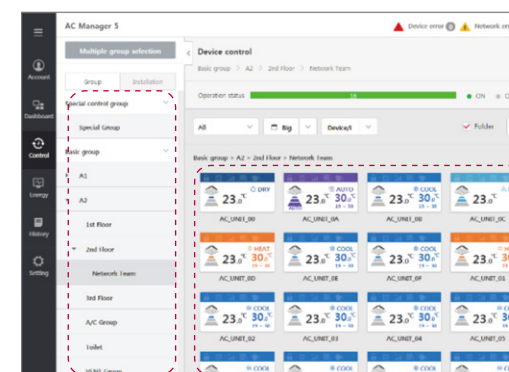

Interlocking with 3rd party equipment

AC Smart 5 can make operation scenario with 3rd party equipment by ACS IO Module. Control coverage is expanded. (Air conditioner only → Sensors, Fans, Pumps, Switches...)

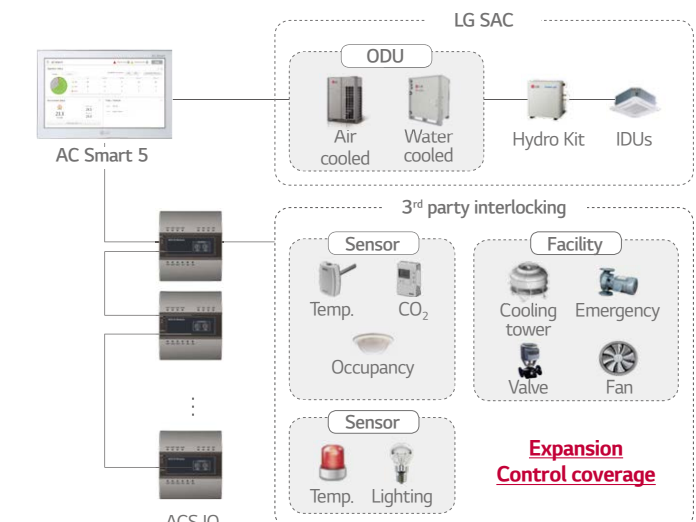

ACP 5

Advanced solution for BMS integration up to 256 units via BACnet and Modbus protocol as well as its own smart management function with web server interface.



PACP5A000

Features & Benefit

- The central controller allows control of the LG HVAC system to various platforms. (PC, Smartphone, Tablet)
 - DI :10 / DO : 4
 - Max. 256 IDU control
 - BACnet IP/Modbus TCP
 - Schedule
 - Map View (Visual Navigation)
 - Time limit control / Auto change over
 - Energy monitoring
 - History / Operation Trend
 - Interlock with 3rd party equipment (ACS IO, ACU IO Module is needed)
 - Multi level grouping
 - Emergency stop & alarm
 - Error alarm by E-mail

Model Name	PACP5A000
Size (W x H x D, mm)	270 x 155 x 65
Interfaceable Products	MULTI V / ERV / ERV DX / HYDRO KIT / THERMA V / AHU kit / LG Chiller ¹⁾
Maximum number of units	256
Individual / Group Control	On & Off / Mode / Temperature / Fan speed
Individual Controller Lock	Temperature / Mode / Fan speed / All
Advanced Function Setting and Display ²⁾	Comfort Cooling / ODU Low Noise / ODU Defrost Mode / Comfort Level display / CO ₂ Level display (for ERV / ERV DX) / Night Time Free Cooling (for ERV / ERV DX)
Error Check	○
Schedule	Weekly / Monthly / Yearly / Exception day
Web Access	○
Emergency Stop & Alarm Display	○
Power Consumption Monitoring (with PDI)	○
Auto Changeover / Setback	○
Temperature Limit	○
Operation Time Limit	○
Visual Navigation	○
Operation Trend	○
Interlock Control	○
Virtual Group Control	○
ODU Capacity Control	○
Energy Navigation (with PDI)	○
Daylight Saving Time	○
External IO Port	DI 10 / DO 4
BMS Integration ³⁾	BACnet IP / Modbus TCP
IPv6 Support	○

※ ○ : Applied, - : Not Applied
 1) Chiller Option Kit (PCHLLN000) is required
 2) It is only available in some products
 3) For the detail point list, please refer to the installation manual

Overview

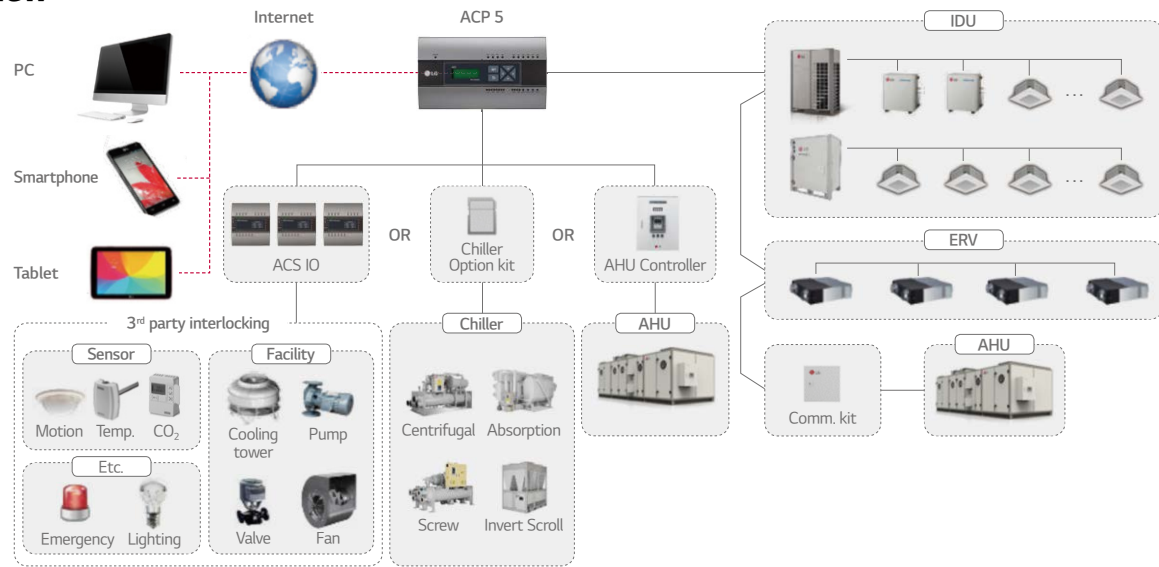

Advanced Network Accessibility



Energy Navigation

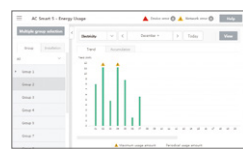

BACnet IP / Modbus TCP

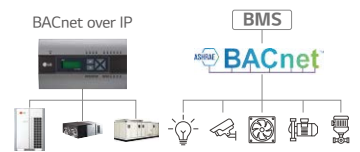

Multi level group / Special control group



ACP LONWORKS GATEWAY

LonWorks easily link LG air conditioners and other existing building systems. By including ACP control function, the controlling continues even when error occurs with BMS.



PLNWKB000

Features & Benefit

- Connect to use Lonworks® protocol and LG air conditioner protocol
- Process Ability (Max. connection) : Indoor unit 64EA, AHU Control Kit : Max. 16EA
- Self installation verification using interne (Web Server Included)
 - Diagnosis of communication status on LG Air-conditioner network
- It offers a variety of functions as ACP which allows the customer to efficiently control various types of equipment from the customer's own Integration.

Control	Monitoring
On / Off Command	On / Off
Operation Mode Setting	Operation Mode
Lock	Lock
Temperature	Temperature
Fan Level	Fan Level
Fan Direction Auto	Fan Direction Auto
Mode Lock	Mode Lock
Fan Level Lock	Fan Level Lock
Temperature Lock	Temperature Lock
Temperature Lower Limit	Temperature Lower Limit
Temperature Higher Limit	Temperature Higher Limit
Peak Convert Cycle	Peak Convert Cycle
Peak Setting	Peak Setting
Temperature Unit	Temperature Unit
Total Temperature Lock	-
Total On / Off	-
Total Temperature	-
-	Product Type
-	Product Address
-	Current Temperature
-	Alarm
-	Power
-	Error Code
-	Peak Current Operating Percent
-	Total Accumulate Power

※ ○ : Applied, - : Not Applied

Overview

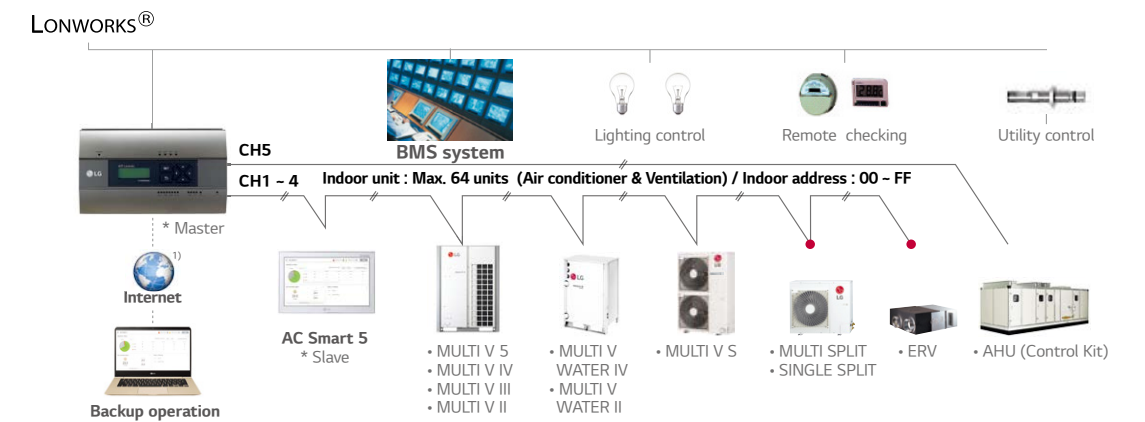

1) Assignment of public IP address is required to access central controller through internet. • Appropriate PI 485 should be used according to PDB (Product Data Book)

PI 485

PI 485 converts LG air conditioner's protocol to the RS485 protocol for the central controller



PHNFP14A0

- Power : Connected with the Indoor Units
- 1 for Each Indoor Unit - Indoor Unit (ERV)

AC MANAGER 5

Multiple ACP and AC Smart integration solution to manage multi sites up to 8,192 units as a single system.



PACM5A000

Features & Benefit

- Consol Type : No needs software installation and lock-key
- Max. 8,192 IDU Control
- Schedule
- Map View (Visual Navigation)
- Time limit control / Auto change over
- Energy Monitoring / Navigation
- History / Operation Trend
- Emergency stop & alarm
- Error alarm by E-mail
- Multi Language
(Eng, Ita, Spa, Por, Rus, Fra, Ger, Tur, Pol, Chi, Kor)

Model Name	PACM5A000
Size (W x H x D, mm)	270 x 155 x 65
Interfaceable Products	MULTI V / ERV / ERV DX / HYDRO KIT / THERMA V / AHU kit / LG Chiller ¹⁾
Maximum number of units	8,192 (supports 32 ACP 5 or AC Smart 5)
Individual / Group Control	On & Off / Mode / Temperature / Fan speed
Individual Controller Lock	Temperature / Mode / Fan speed / All
Error Check	○
Schedule	Weekly / Monthly / Yearly / Exception day
Web Access	○
Emergency Alarm Display	○
Power Consumption Monitoring (with PDI)	○
Auto Changeover / Setback	○
Temperature Limit	○
Operation Time Limit	○
Visual Navigation	○
Operation Trend	○
Interlock Control	○
Virtual Group Control	○
ODU Capacity Control	○
Energy Navigation (with PDI)	○

※ ○ : Applied, - : Not Applied
 1) Chiller Option Kit (PCHLLN000) is required
 Note : AC Manager 5 requires ACP 5 or AC Smart 5

Overview

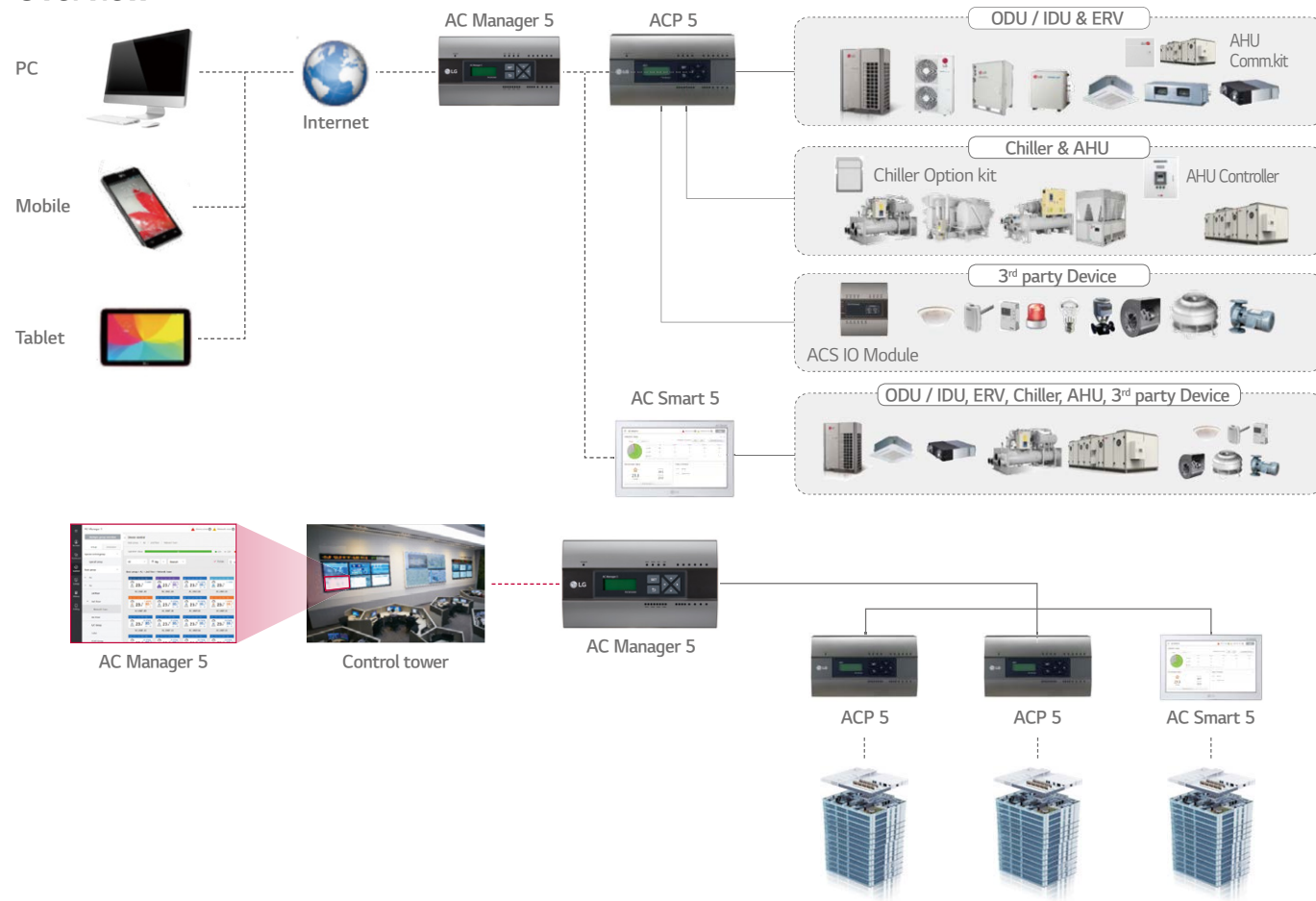

Feature

Stand-alone

Integrated with S/W program and Hardware platform, it is convenient to install since users no longer need to install program with lock-key on PC.

Up to 8,192 Connections for Indoor Units

Administrators can easily and conveniently manage a variety of LG HVAC equipment. Also, it is available to manage many buildings or areas at one place via AC Manager 5.

Advanced Network Accessibility & User Friendly GUI (reddot award)

As an advanced central controller, AC Manager 5 offers flexible interface for each user by assessing the device screen and automatically customizing the layout to provide the most optimized interface.

Energy Navigation & Energy Usage Trend

Energy navigation is the function to set the target usage amount to limit the monthly power consumption and to control so that the total accumulated power consumption does not exceed the target usage amount. It performs total of 7 control levels with the estimated/actual usage amount exceeding ratio compared to the monthly target usage amount. For the control method, there are indoor unit operation ratio, outdoor unit capacity control, and indoor unit operation control.

Peak Control

This function can reduce electricity use. There are two kinds of control logic. Energy saving effect by indoor unit operation rate control. Load management effect by outdoor unit capacity control.

Multi Level Group Composition

You can freely apply layer structure such as building, floor, zone, etc. and set the group as the same as the site composition to control and monitor the devices. Special control group You can additionally compose frequently used groups such as VIP Room, executive room, etc. regardless of the building structure.

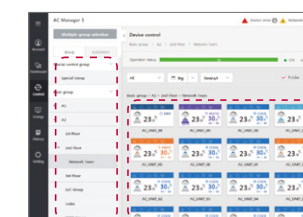
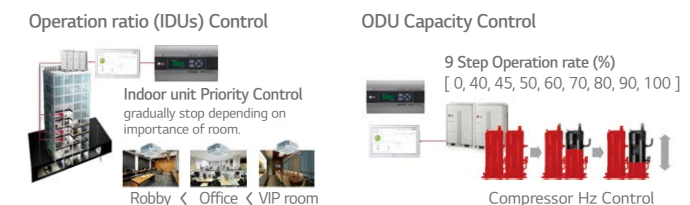
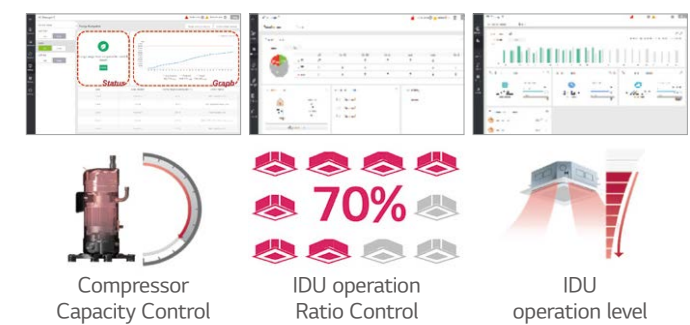
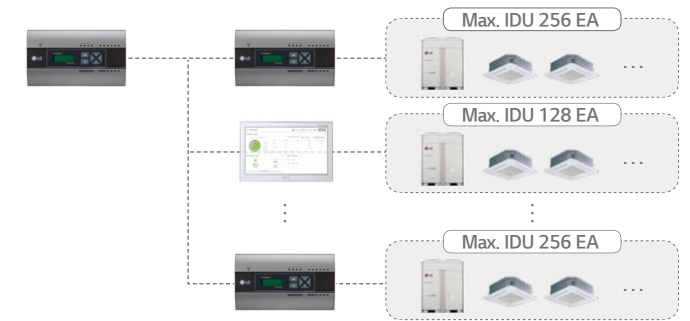

OUTDOOR UNITS

INDOOR UNITS

HOT WATER SOLUTION

VENTILATION SOLUTIONS

CONTROL SOLUTIONS

ACCESSORIES

KNX GATEWAY 1)

Specially designed to allow monitoring and bidirectional control of all the parameters and functionality of LG air conditioners from KNX protocol.



Model Name	Max. Connection Indoor Units
LG-AC-KNX4	4
LG-AC-KNX8	8
LG-AC-KNX16	16
LG-AC-KNX64	64

LG-AC-KNX4 / LG-AC-KNX8
LG-AC-KNX16 / LG-AC-KNX64

Features & Benefit

- Easy installation, direct connection to all outdoor units (communication interface PMNFP14A1, when needed) and Heat recovering units (communication interface PHNFP14A0, when needed) through the RS485 Bus.
- Great integration flexibility. Using the supplied software LinkBoxEIB, a complete set of communication objects can be accessed.
- Direct connection to KNX bus
- Independent management of communications
- Power supply : 9 to 24V DC or 24V AC
- Standard DIN-Rail 6 modules enclosure
- Maximum connection unit
- LG Central controller (for example, AC Smart) and PDI can be operated with KNX gateway.

Link BoxEIB Configuration Software for IntesisBox® KNX Serious

Easy to use tool for the configuration of IntesisBox, in a fast and effective way. It offers the maximum integration possibilities with a minimal knowledge required on the system to be integrated.

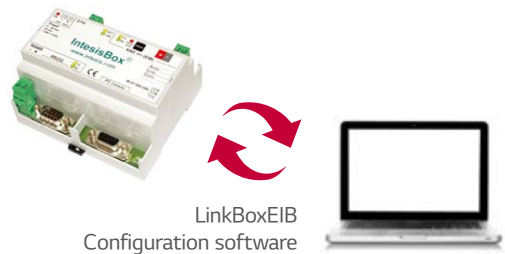

- Only needed during configuration.
- One single tool for the configuration of the whole range of IntesisBox KNX series gateways.
- Supplied with IntesisBox with no additional cost.
- Configuration examples for all systems that can be integrated.
- Mapping table editable using excel, allowing a simple and fast association of KNX Group Addresses, exported from ETS, to IntesisBox's datapoints.
- Includes powerful and useful features for configuration, setup and troubleshooting.

Installation Scene

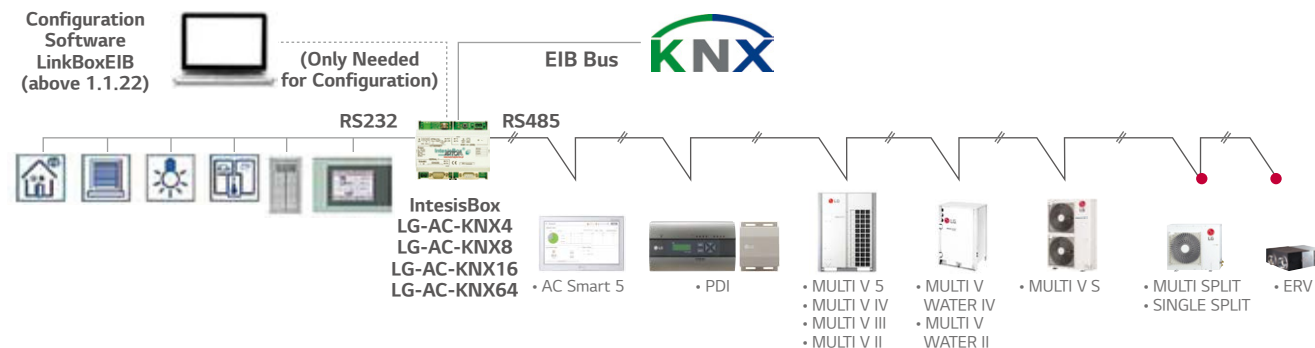

1) This product is provided by INTESIS.
● Appropriate PI 485 should be used according to PDB

MODBUS RTU GATEWAY

Providing Modbus RTU connection between LG Air conditioners and BMS.



PMBUS00A

Features & Benefit

- Function
 - MODBUS RTU communication with MODBUS master controller
 - MODBUS RTU slave (RS485) / 9,600 bps
 - Applicable for Multi V 5
 - Size (W x H x D) : 53.6 x 89.7 x 60.7
 - Max. 16 IDUs with single module / Max. 64 IDUs with 4 modules
 - Power : DC 12V

Coil Register (0 x 01)

No.	Data Bit		Function
	Air Conditioner	Ventilator	
1	Operate (On / Off)	Operate (On / Off)	0 : Stop / 1 : Run
2	Auto Swing	Aircon Operate (On / Off)	0 : Disable / 1 : Enable
3	Filter Alarm Reset	Filter Alarm Reset	0 : Normal / 1 : Reset
4	Lock Remote Controller	Lock Remote Controller	0 : UnLock / 1 : Lock
5	Lock Operate Mode	Lock Operate Mode	0 : UnLock / 1 : Lock
6	Lock Fan Speed	Lock Fan Speed	0 : UnLock / 1 : Lock
7	Lock Target Temp.	Lock Target Temp.	0 : UnLock / 1 : Lock
8	Lock IDU Address	Lock IDU Address	0 : UnLock / 1 : Lock
9	Reserved	Quick Ventilate	0 : Disable / 1 : Enable
10	Reserved	Energy Save	0 : Disable / 1 : Enable

Discrete Register (0 x 02)

No.	Data Bit		Function
	Air Conditioner	Ventilator	
10001	Connected IDU	Connected IDU	0 : Disconnected / 1 : Connected
10002	Alarm	Alarm	0 : Normal / 1 : Alarm
10002	Filter Alarm	Filter Alarm	0 : Normal / 1 : Filter Alarm

Holding Register (0 x 03)

No.	Data Bit		Function
	Air Conditioner	Ventilator	
40001	Operate Mode	Operate Mode	0 : Cooling, 1 : Dehumidifying, 2 : Fan, 3 : Auto, 4 : Heating
40002	Fan Speed	Fan Speed	1 : Low, 2 : Mid, 3 : High, 4 : Auto
40003	Target Temp.	Target Temp.	16.0 - 30.0 [°C] x 10
40004	Target Temp. Limit (Upper)	Target Temp. Limit (Upper)	16.0 - 30.0 [°C] x 10
40005	Target Temp. Limit (Lower)	Target Temp. Limit (Lower)	16.0 - 30.0 [°C] x 10
40006	Reserved	Vent. Operate Mode	0 : HEX, 1 : Auto, 2 : Normal

Input Register (0 x 04)

No.	Data Bit		Function
	Air Conditioner	Ventilator	
30001	Error Code	Error Code	0 - 255 ※ Please refer to the product error table.
30002	Room Temp.	RA Temp.	-99.0 - 99.0 [°C] x 10
30003	Pipe In Temp.	OA Temp.	-99.0 - 99.0 [°C] x 10
30004	Pipe Out Temp.	SA Temp.	-99.0 - 99.0 [°C] x 10
30005	Reserved	Pipe In Temp.	-99.0 - 99.0 [°C] x 10
30006	Reserved	Pipe Out Temp.	-99.0 - 99.0 [°C] x 10

Installation Scene

- Single module
Max. 16 indoor units with a single module

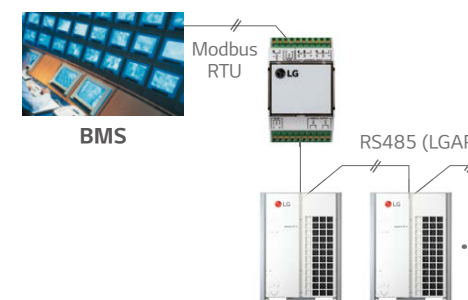

- Multiple module
Max. 64 indoor units with 4 modules in one Modbus communication line

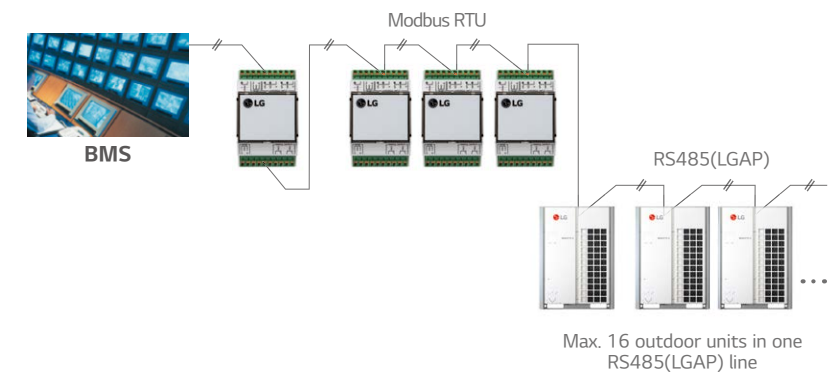

INTEGRATION DEVICE



PDI (POWER DISTRIBUTION INDICATOR)

PDI shows distributed power consumption of up to 128 indoor units



PQNUD1S40 (Premium, 8 port)
PPWRDB000 (Standard, 2 port)

Model Name	PQNUD1S40	PPWRDB000
Size (W x H x D, mm)	270 x 155 x 65	
Interfaceable Products	Air conditioner, ERV DX	
Maximum Number of Power Meters	EHP : 8 Watt meter GHP : 4 Watt meter / 4 Gas meter	EHP : 2 Watt meter GHP : 1 Watt meter / 1 Gas meter
Maximum Number of Indoor Units	MULTI V : 128	
Data Backup When Power Outage	○	
Power Input	PDI : AC 24V, Transformer : AC 220V	

※ ○ : Applied, - : Not Applied

Features & Benefit

- Total and indoor power consumption monitoring is possible.
- When connected to the LG central controller, it is possible to expand functions such as energy monitoring, energy saving operation and target usage setting.
- It is also possible to distribute gas consumption in addition to electricity.

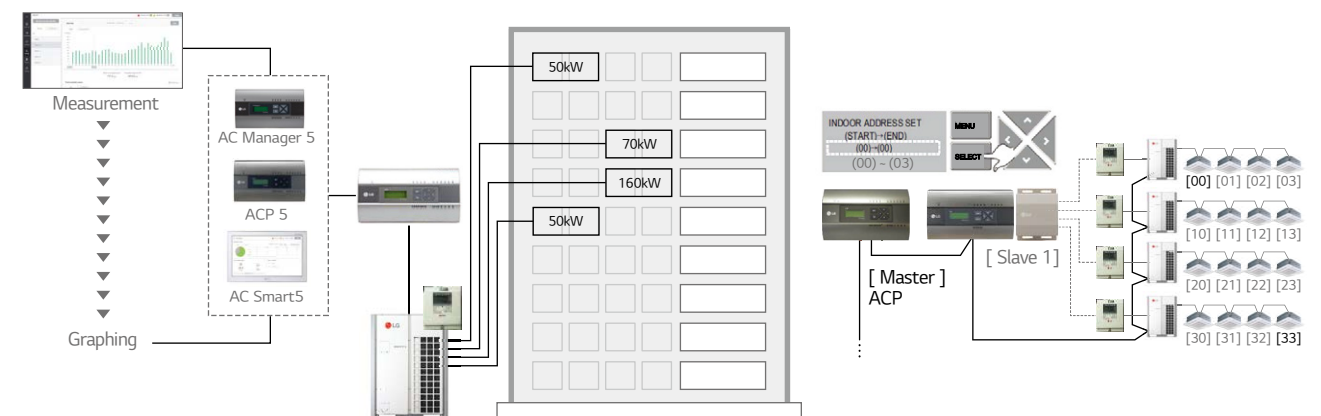
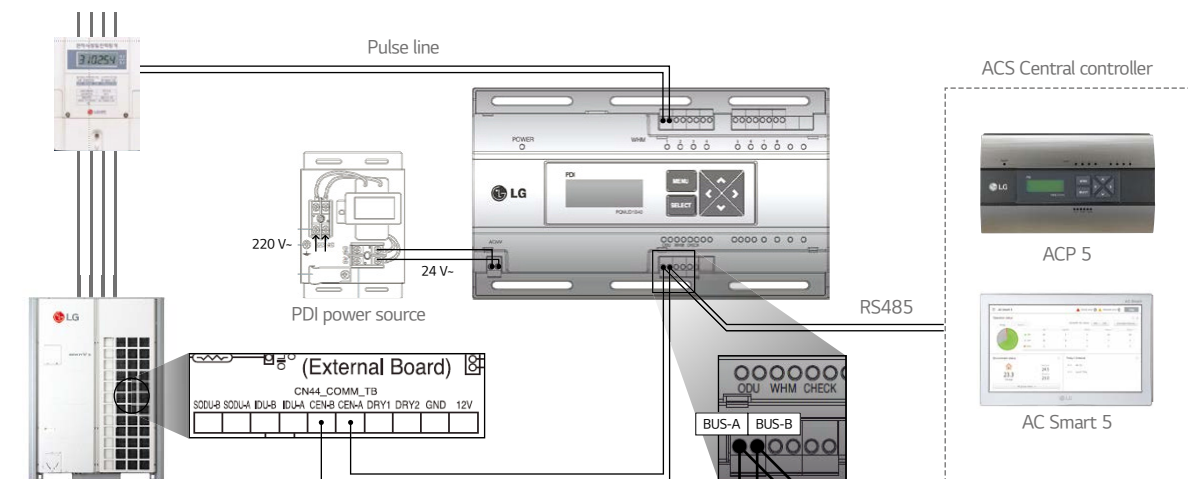

Note : 1. Power cable and type could be different from this scene depending on the Outdoor unit's specification
2. Measured power consumption could be different between PDI and Watt meter
3. Applicable Central Controller : ACP 5, ACP Lonworks, AC Smart 5, AC Ez Touch
(Combination : we recommend to connect separated watt meter for Outdoor units to have correct power distribution value)

ACS IO MODULE

This module can be connected with ACP 5 or AC Smart 5 controller if additional I/O points such as DI/DO and AI/AO for 3rd party devices control and monitoring are needed.



PEXPMB000

Model Name	PEXPMB000	
Linkable Products	PACS4B000 PACP4B000 PACS5A000 PACP5A000	
Communication	RS-485	1 ch.
I/O	Digital Input	3 port
	Digital Output	3 port
	Universal Input ¹⁾	4 port
	Analog Output	4 port

	Value Spec	Min.	Max.
Analog Input	NTC 10k	0.68k Ω	1.77k Ω
	PT 1000	803 Ω	1,573 Ω
	Ni 1000	871.7 Ω	1,675.2 Ω
	DC (Voltage)	0V	10V
Analog Output	DC (Current)	0mA	20mA
	-	0V	10V
Digital Input	Binary Input (Non Voltage)	-	-
Digital Output	Normal open	-	30VAC / 30VDC, 2A

※ ○ : Applied, - : Not Applied
1) The type of UI (Universal Input) is selectable among Digital Input and Analog Input

Features & Benefit

- Interlocking with 3rd party equipment LG Central controller can make operation scenario with 3rd party equipment by ACS IO Module.
- Control coverage is expanded.
(Air conditioner only → Sensors, Fans, Pumps, Switches...)

Key Application

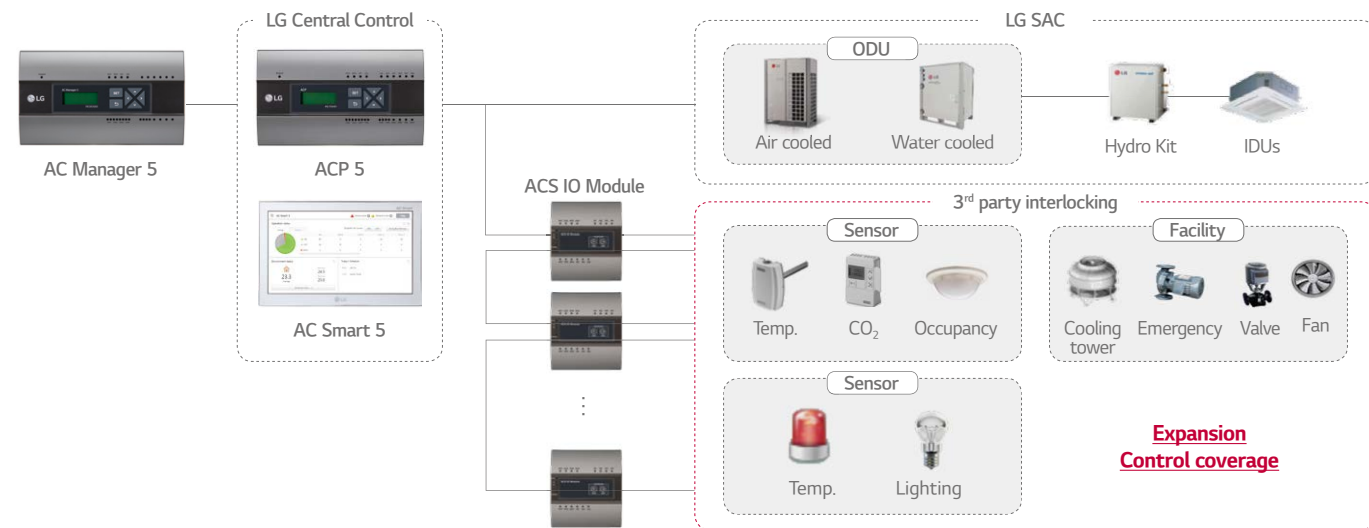

* DI : Digital Input, DO : Digital Output, UI : Universal Input, AO : Analog Output / Please contact our regional office to have connectable relay specification for analog output

ACU IO MODULE NEW

This module can be connected with ACP 5 or AC Smart 5 controller if additional I/O points such as UIO / UI / UO for 3rd party devices control and monitoring are needed.

ACU.UIO



PEXPMB300

ACU.UO



PEXPMB200

ACU.UI



PEXPMB100

Module Name	PEXPMB300	PEXPMB200	PEXPMB100
Linkable Products	PACS5A000, PACP5A000		
Communication RS-485	2 ch. ¹⁾	1 ch.	1 ch.
Digital Input	-	-	3port
Digital Output	2port	6port	-
Universal Input ²⁾	4port	-	6port
Analog Output	2port	4port	-

	Value Spec	Min.	Max.
Analog Input	DC (Voltage)	0V	10V
Analog Output	DC (Voltage)	0V	10V
Digital Input	Binary Input (Non Voltage)	-	-
Digital Output	Normal Open	-	30VDC, 1A

※ ○ : Applied, - : Not Applied
1) 1ch is reserved for internal communication
2) The type of UI (Universal Input) is selectable among Digital Input and Analog Input

Features & Benefit

- Interlocking with 3rd party equipment LG Central controller can make operation scenario with 3rd party equipment by ACU IO Module.
- Control coverage is expanded.
(Air conditioner only → Sensors, Fans, Pumps, Switches...)

CHILLER OPTION KIT

LG central controller 5 series with Chiller Option Kit can provide LG chiller remote control and cycle monitoring.



PCHLLN000

Model Name	PCHLLN000
Monitoring Points	Evaporator status / Compressor status (Scroll, Screw, Centrifugal chiller only) / Condenser status / Generator status (Abs. chiller only)
On / Off	○
Target Temp. setting	○
Mode Change	Scroll chiller only
Schedule	○
Interfaceable Products	Scroll, Screw, Centrifugal, Absorption (LG Only)

※ ○ : Applied, - : Not Applied

Cycle Display Example

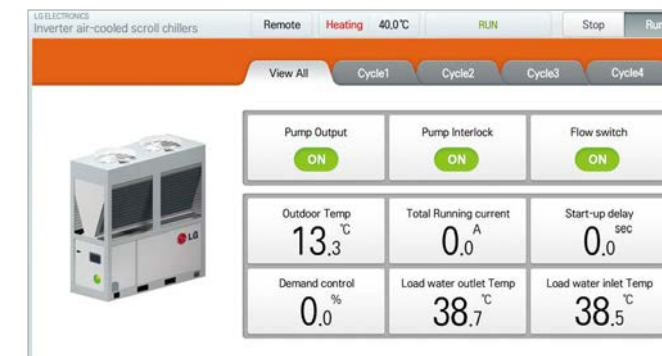

Installation Scene

- Chiller Option Kit installation of LG HVAC Solution product should be conducted by a specialized installation service engineer.
- Chiller Option Kit installation can be proceeded with a SD Card.
- The SD Card can install Chiller Option Kit in one LG HVAC Solution product.

Insert the SD Card in the LG HVAC Solution product. If a backup SD Card is inserted, replace it with a ChillerOption Kit SD Card.



DRY CONTACT

Connection between an indoor unit and external devices to control various functions.

Model Name	PDRYCB000	PDRYCB400	PDRYCB300	PDRYCB500
Case	○	○	○	○
Input Port	1	2	8	-
Comm. Protocol	-	-	-	Modbus RTU
Power	AC 220V	Connect to Indoor unit PCB (CN_CC)		
Aircon	On / Off	○	○	○
	Oper Mode	-	○	○
	Set Temp.	-	(Select & Fix)	(Select & Fix)
	Fan Speed	-	-	○
	Thermo-Off	-	(Select & Fix)	○
	Energy Saving	-	(Select & Fix)	-
	Lock/Unlock	-	(Select & Fix)	-
	On / Off	○	-	○
	DHW On / Off	-	-	○
	Thermo-Off	-	-	○
	Oper Mode	-	-	○
	Silent Mode	-	-	○
AWHP	Emergency Mode	-	○	-
	On / Off	○	-	○
	Oper Mode	-	-	○
Vent	Aircon Mode	-	-	○
	Additional Mode	-	-	○
	Fan Speed	-	-	○
Output	Operation Status	○	○	○
	Error	○	○	○
	Room Temp.	-	-	○

- ※ ○ : Applied, - : Not Applied
 Note: 1. Compatibility of PDRYCB300
 - Can use with all types of aircon indoor units after 2010 (Cassette, Ducted, Convertible, Applied PAC, Wall mounted, Console)
 - Can not use with Single package models
 - AWHP : 3 series split and monobloc models
 2. Compatibility of PDRYCB400
 - Can use with all types of aircon indoor units after 2010 (Cassette, Ducted, Convertible, Applied PAC, Wall mounted, Console)
 - Can not use with single package models
 - Can not use with AWHP, Hydrokit models
 3. (Select & Fix) : This function is preset by rotary switch.

PDRYCB000



PDRYCB400

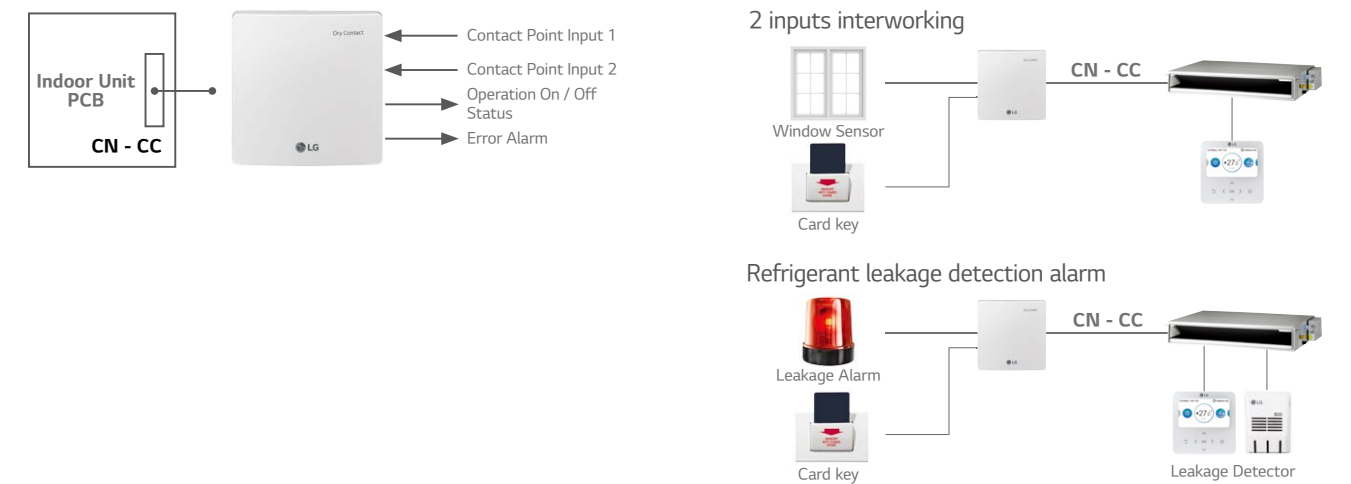

PDRYCB300



PDRYCB500

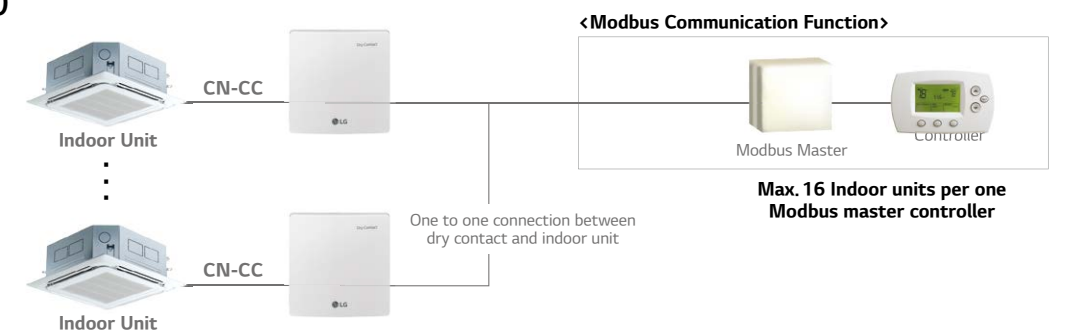

* Please contact our regional office to check the compatibility with 3rd party room controller

GROUP CONTROL WIRE

Cables used to connect a wired remote controller up to 16 indoor units.



PZCWRCG3

Model Name	PZCWRCG3
Y-type Cable	0.25m Length
Long Cable	9.6m Length

Installation Scene

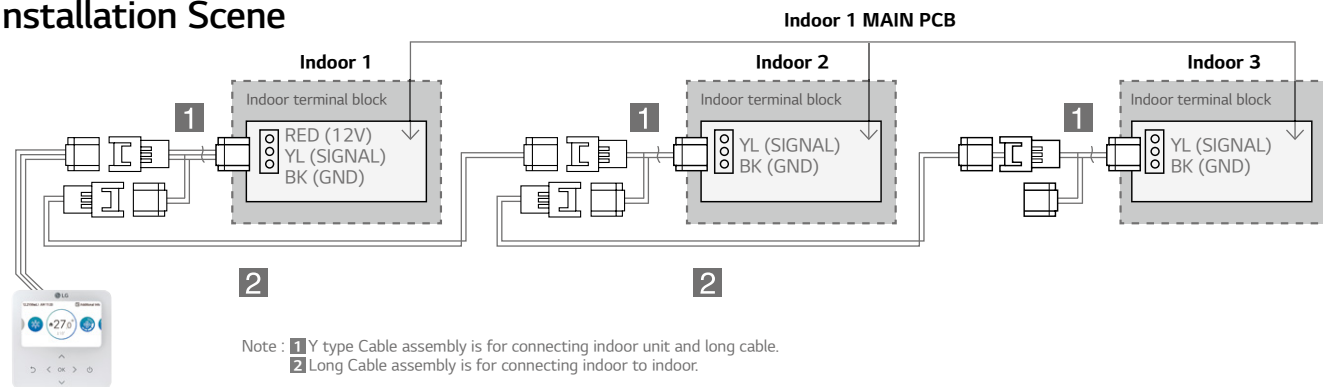

REMOTE TEMPERATURE SENSOR

Sensor for detecting the room temperature.



PQRSTAO

Features & Benefit

- It detects the exact room temperature instead of indoor unit's air temperature sensor
- Applied to Ceiling Mounted Cassette, Ceiling Concealed Duct, THERMA V and HYDRO KIT
- Extension cable (15m) is included

Installation Scene

1. Wire to the control box in the indoor unit by removing the existing thermistor and connect the extension cable its place.
2. Cut the extension cable to the appropriate length and connect the screw terminal of the remote sensor.

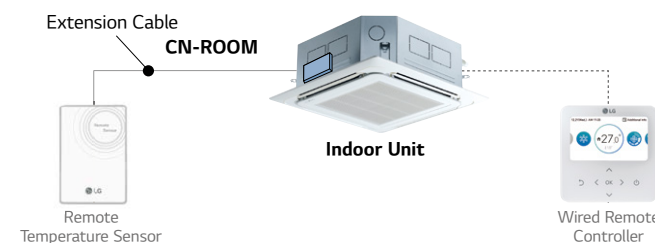

LOW PROFILE REMOTE TEMPERATURE BUTTON SENSOR

This installs easily and discreetly into a wall and then connects to indoor unit



ZRTBS01

Model Name	ZRTBS01
Operation Range	-40°C to 85°C (0 to 100%RH, Non-condensing)
Sensing Element	Thermistor
Sensing Element Accuracy	0.2°C (0 to 70°C)
Material	Etched Teflon
Wire Leads	Length: 15m Thickness: 0.33mm²
Mounting	10mm hole, push in plastic sheath with peel off tape strip
Enclosure Material Ratings	Plastic, NEMA 1, UL94

Features & Benefit

- Ideal for locations where aesthetics are as important as the temperature measurement.
- Inconspicuous wall sensor that mounts easily by pushing through a 10mm hole and secured with a peel off tape strip.
- Small flush sensor mounting.
- Accurate direct air measurement.
- Paintable with latex or oil base.

Key Application

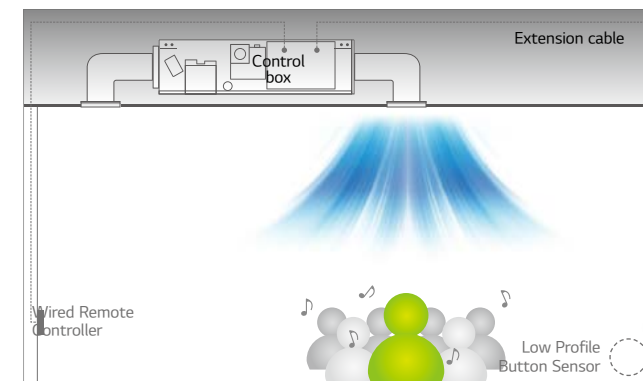

Models Applied

- LG indoor units excluding Wall-Mounted Type

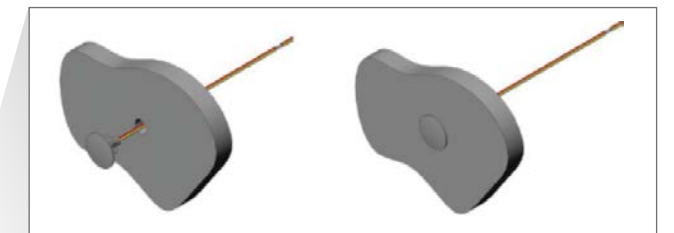

Installation Scene

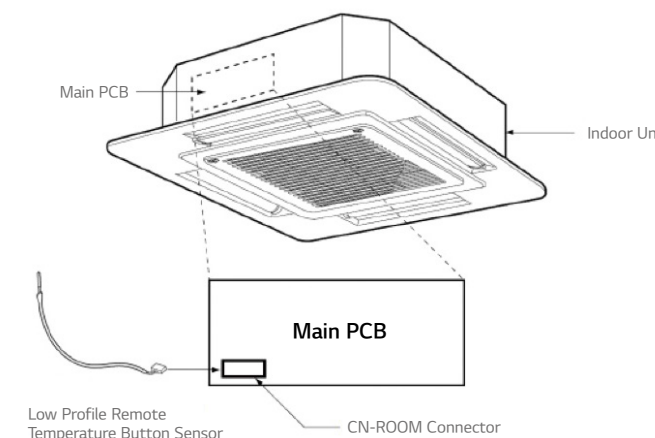

Drawing

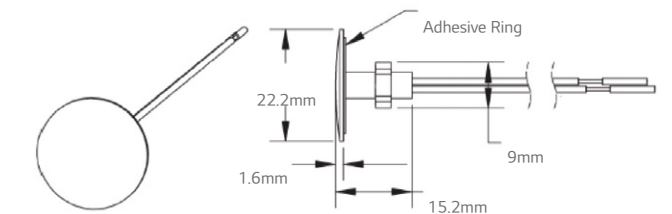

ZONE CONTROLLER

Controls air conditioning up to 4 zones by external thermostat.

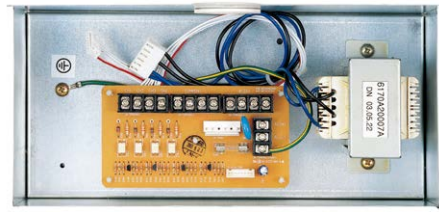

ABZCA

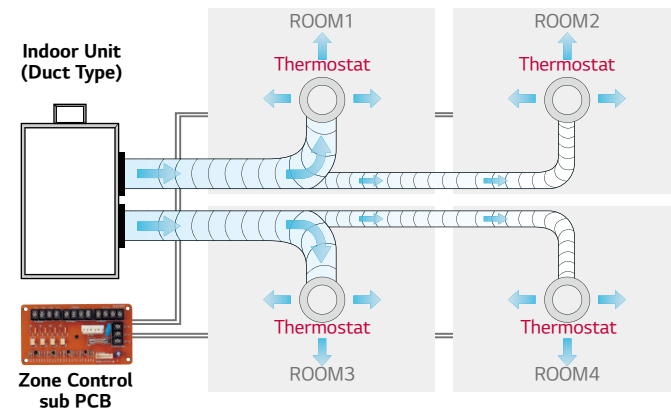

Features & Benefit

- Controls different zones (up to 4 zones) by external thermostat (AC 24V)
- Maintain proper air volume of each zone
- Auto variation of dampers
- Auto control of fan speed and On / Off operation

Models Applied

- Ceiling Concealed Duct (refer to Product Data Book for applicable models)

Wiring Diagram

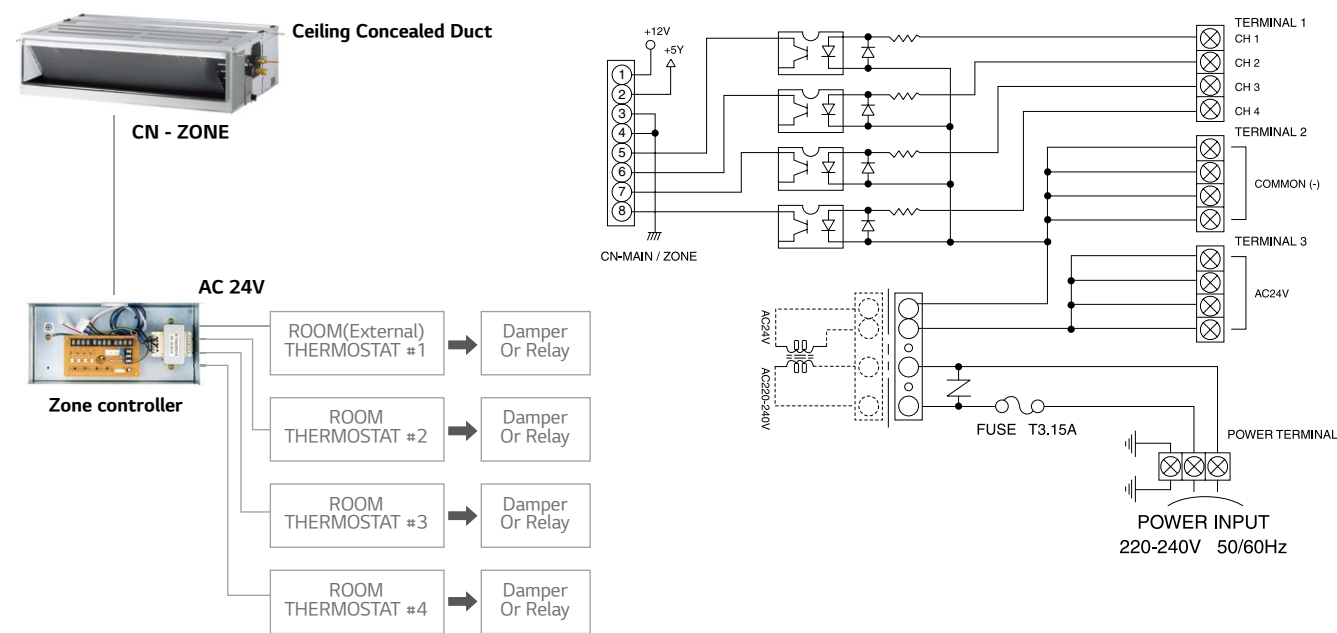

IO MODULE

Interface module between system air conditioner's outdoor unit and external device.



PVDSMN000

Features

- Demand control
- Low noise operation
- Output outdoor or indoor unit operation status
- Output error status

Description

• IO Module is communication interface module for connection between MULTI V 5 and external IO (Input / Output Module) devices.

Note : IO Module is not compatible for MULTI V III

Models Applied

- MULTI V 5
- MULTI V S
- MULTI V WATER IV

Part Description

- 1) Digital Input Part (DI : Dry Contact Input)
 - Demand control by contact input (3 Step)
 - Low Noise Operation input
 - Priority Setting input : Setting the priority of demand control command (Capacity control for external signal from DDC vs Peak control by LG Central controller)
 - Open : External signal has priority to central controller (Default)
 - Close : Central controller has priority to external signal
- 2) Analog Input Part (AI : DC 0 ~ 10V)
 - Demand control by analog input (10 Step)
- 3) Digital Output Part (DO : AC 250V, Max. 1A)
 - Error status relay output
 - Operation status relay output
 - Valve control

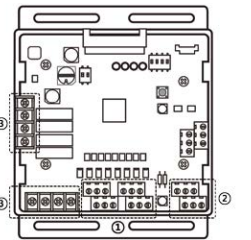

Key Application

Demand Control

Provides variable setting for demand control according to input method to reduce power consumption. This function supports 2 types of input signal : AI (0 ~ 10V, 10 Step) and contact signal (3 Step).

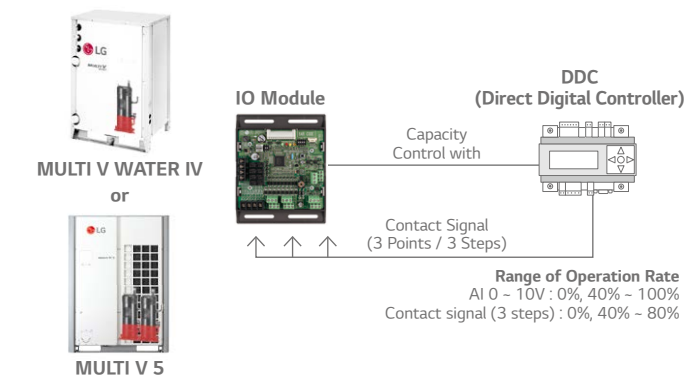

Low Noise Operation

To reduce noise level, control outdoor unit's fan speed by dry contact input.

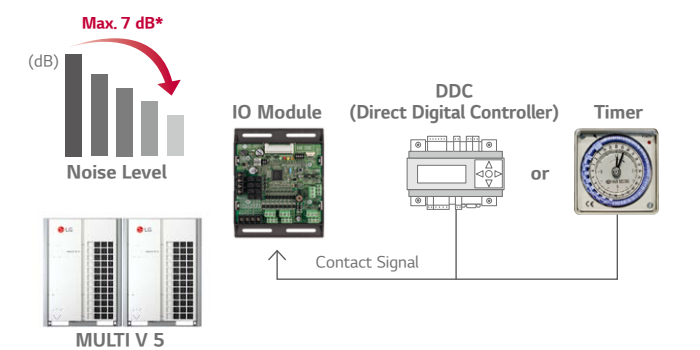

Refrigerant Leakage detection with Pump-down

For safety, IO module close refrigerant valve when Pump-down operation.

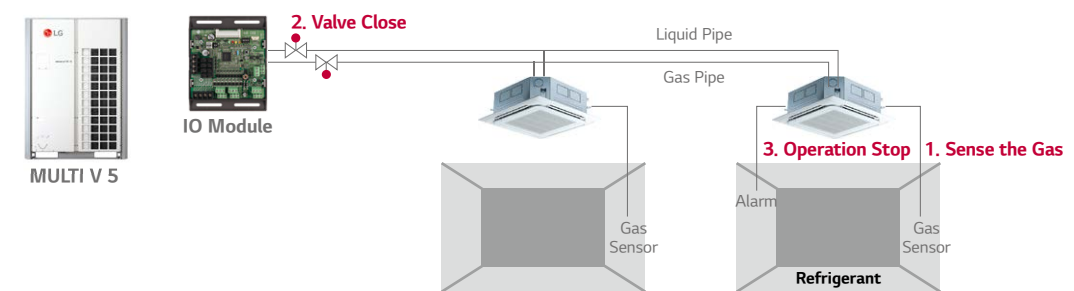

VARIABLE WATER FLOW CONTROL KIT

Accessory developed for controlling the water flow.

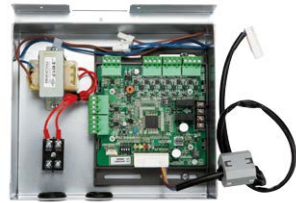

PWFCKN000
(MULTI V WATER IV)

Features

Function

- Water pump or valve control (0 ~ 10V)
- Minimum output voltage setting available
- Operation, error output (AC 250V, Max. 1A)
- Dry contact input and analog output for demand control
- Digital output for operation, error status (AC 250V, Max. 1A)

Advantage

- Water flow consumption reduction
- Pump electricity consumption reduction
- Including IO Module (Dry contact input, Analog input / output, Digital output)
- Using Dry contact and variable water flow control function simultaneously

Wiring Diagram

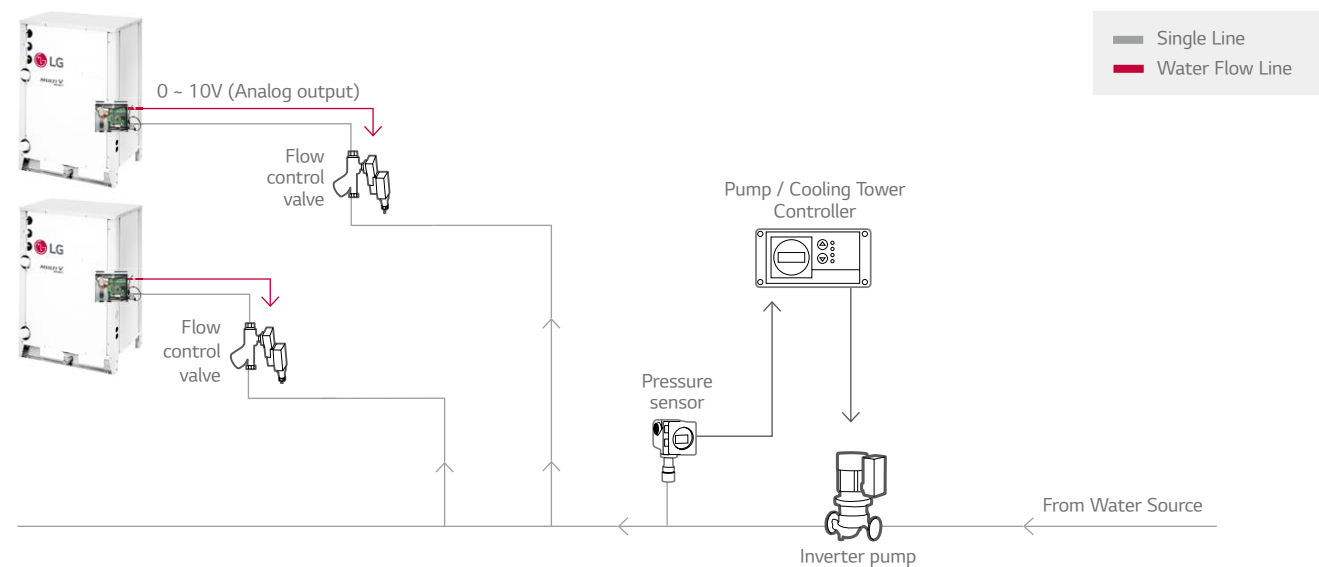

- Flow control valve : Regulates the flow or pressure of a fluid, normally responding to signals generated by independent devices.
- Flow Meter : Measures mass flow rate of a fluid traveling through a tube. (The mass flow rate is the mass of the fluid traveling past a fixed point per unit time.)
- Pressure Sensor : Measures the pressure.

LOW AMBIENT KIT

External integration module for cooling operation with -25°C low ambient temperature.

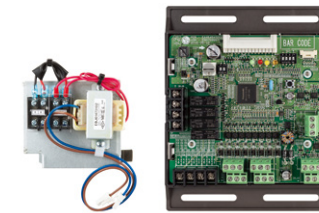

PRVC2

Features

Function

- 25°C Low ambient cooling operation by Low ambient kit and hood with damper (Analog output 0 ~ 10V)
- Demand contro
- Low noise operation
- Output outdoor or indoor unit operation status (AC 250V, Max. 1A)
- Output error status (AC 250V, Max. 1A)

Description

- Low ambient kit supports -25° C cooling operation by making stable condensing pressure with reducing air flow rate from hood and damper control given 0 ~ 10V proportional to condensing pressure.
- Low ambient kit provides IO Module function.
- External snow hood and air damper are required for this item.
- Transformer and terminal block are included.

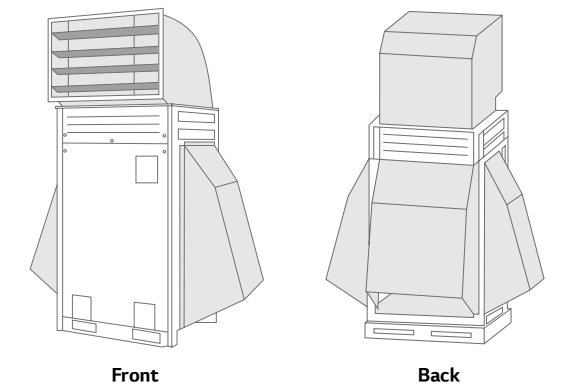

□ : Field Supply item

Models Applied

- MULTI V 5
- MULTI V IV

Installation Scene

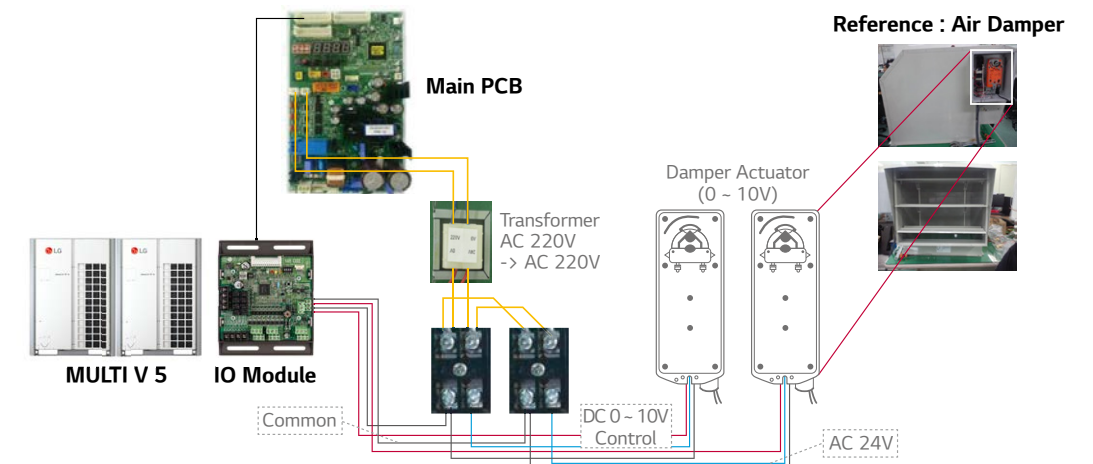

Note : The IO Module can control maximum three actuators. Please, review damper actuator's installation manual.

COOL / HEAT SELECTOR

Cooling, heating, or fan mode can be selected to prevent cooling and heating mixing errors during seasonal changes.



PRDSBM

Features

- Indoor unit mode control without central controller
- Select operation mode : Cooling, Heating, Fan mode
- Mode lock for cooling & heating mixing error-proof during the change of season

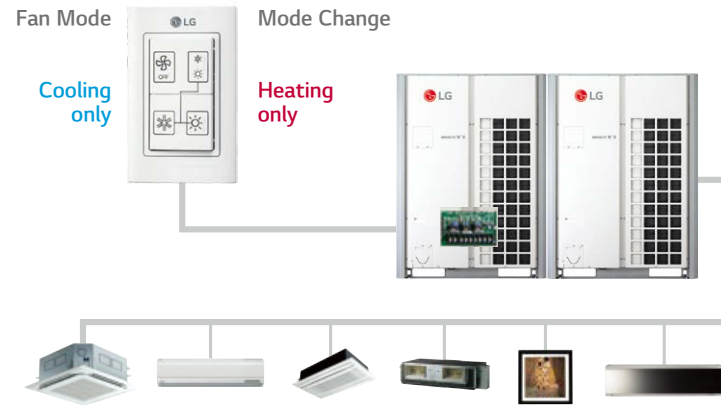

Models Applied

- MULTI V 5
- MULTI V WATER II
- MULTI V PLUS II, MULTI V PLUS
- MULTI V IV
- MULTI V S
- MULTI V WATER IV

Wiring Diagram

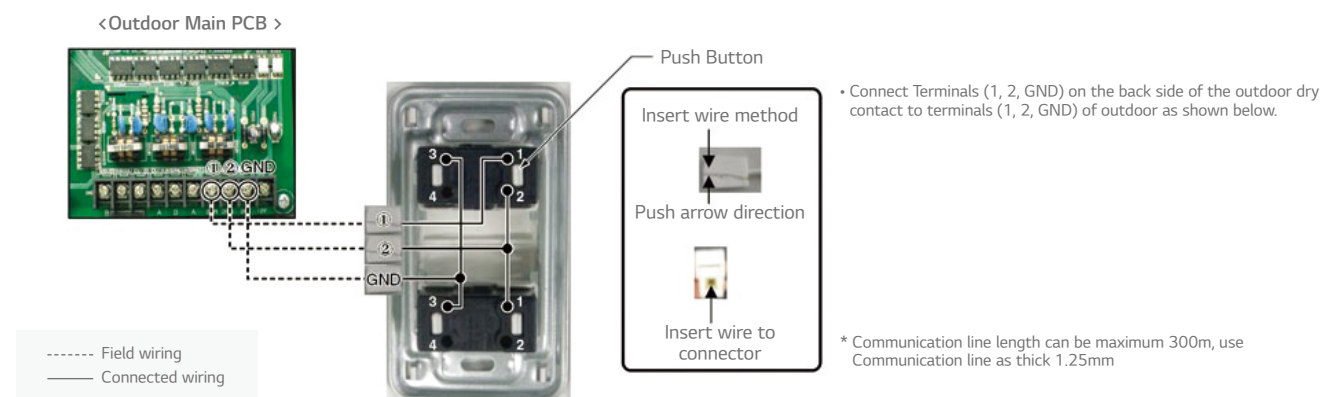

AHU KITS

A solution to connect LG's high efficiency system to the DX coil of an air handling unit for the maximum energy savings.



Specifications

Communication & Control Kit

Type	Model	Combination				Description	Dimensions (mm)		
		Outdoor Unit	EEV Kit	TXV Kit	Centralized Controller		W	H	D
Communication kit	PAHCMR000	Multi V	○	○	○	Return / Room air temperature control by DDC or LG individual / centralized controller	300	300	155
		Single Split	-	-	○				
	PAHCMS000	Multi V	○	○	○	Discharge air temperature control by DDC or LG individual / centralized controller	380	300	155
		Single Split	-	-	○				
Control kit	PRCKD21E	Multi V	-	○	○	Max. capacity 1 - 4 master outdoor unit	600	750	285
	PRCKD41E	Multi V	-	○	○	Max. capacity 5 - 8 master outdoor unit	600	750	285

※ ○ : Applied, - : Not Applied

Expansion Valves

Type	Model	Capacity Range	Pipe Diameter (mm)				Dimensions (mm)		
			Liquid (ODU)	Liquid (AHU)	Gas (ODU)	Gas (AHU)	W	H	D
EEV Kit (Electronic Expansion Valve)	PRLK048A0	1.3 - 10 HP	12.7	12.7	-	-	217	404	83
	PRLK096A0	12 - 20HP	12.7	12.7	-	-	217	404	83
TXV Kit (Thermal Expansion Valve)	PATX13A0E	8 - 16HP	15.88	15.88	22.22	22.22	491	238	174
	PATX20A0E	18 - 26HP	15.88	22.22	28.58	28.58	491	238	174
	PATX25A0E	28 - 36HP	22.22	28.58	34.92	34.92	491	238	174
	PATX35A0E	38 - 46HP	28.58	34.92	41.3	41.3	491	238	174
	PATX50A0E	48 - 56HP	28.58	34.92	41.3	41.3	561	291	192

※ ○ : Applied, - : Not Applied

AHU KITS

Communication Kit

HIGH ENERGY EFFICIENCY

LG's DX AHU solutions are capable of performing all indoor air conditioning tasks with success under all operating conditions thanks to their superior performance with high efficiency heat source system.

Solution benefits offer the following advantages:

- High energy efficiency inverter system
- Large range of expansion valves
: 1.3 ~ 20 HP EEV Kit, 8 ~ 56 HP TXV Kit
- Connected to various heat sources
: MULTI V, MULTI V WATER, MULTI V S, SINGLE SPLIT

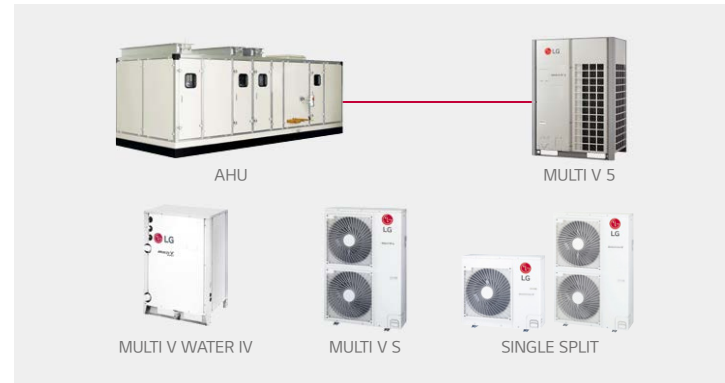

DIVERSE OPTIONS FOR CONTROL

AHU communication kit can be connected to various control system such as LG individual/central controller and DDC¹⁾. It can be directly connected to DDC without separated controller, so DDC can receive product control and monitor information through contact signal or Modbus protocol.

- LG Individual/Central controller supported
- LG controller stand alone or combination with DDC
- Direct wiring between DDC and AHU communication kit
- Embedded Digital I/O and Analog Input
- Modbus RTU protocol supported

1) DDC : Direct Digital Controller

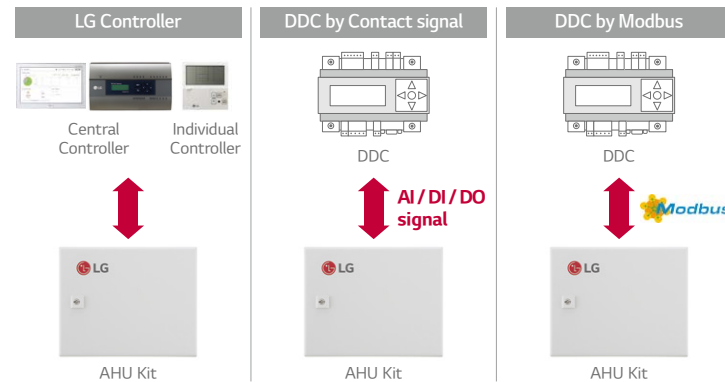

EXPANDABLE SYSTEM DESIGN

LG AHU system can be a suitable solution for various sites due to its application flexibility and wide range of line up with large capacity models. According to the required capacity, a single or multiple module combination is possible thanks to AHU communication kit's modular design.

- Multiple module combination for large capacity AHU

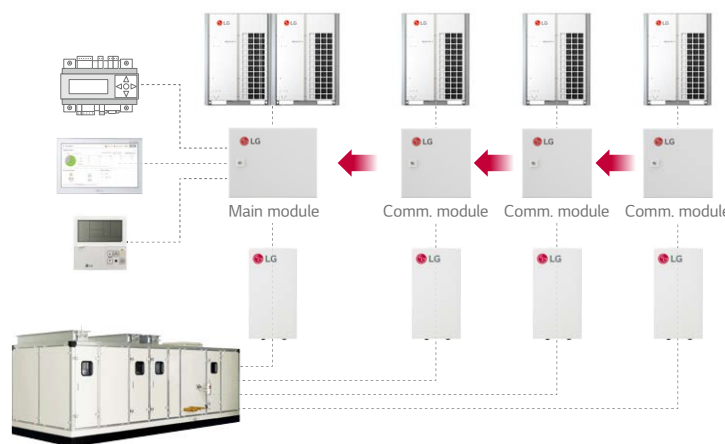

Communication Kit Application

Small Capacity with Single Split + Return / Room Air Temperature Control

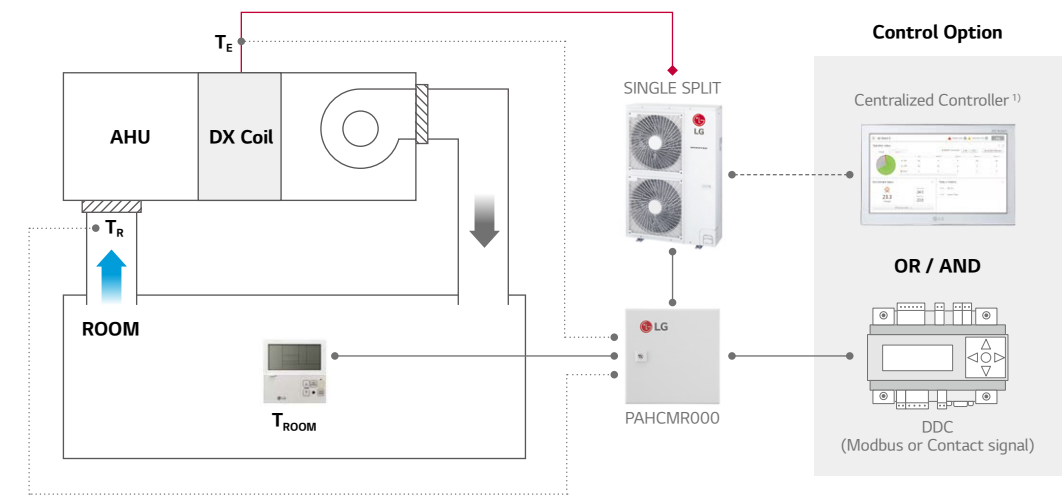
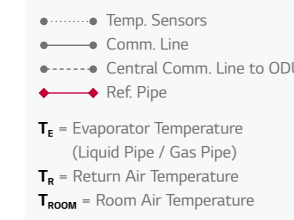

Small Capacity with Single Split + Discharge Air Temperature Control

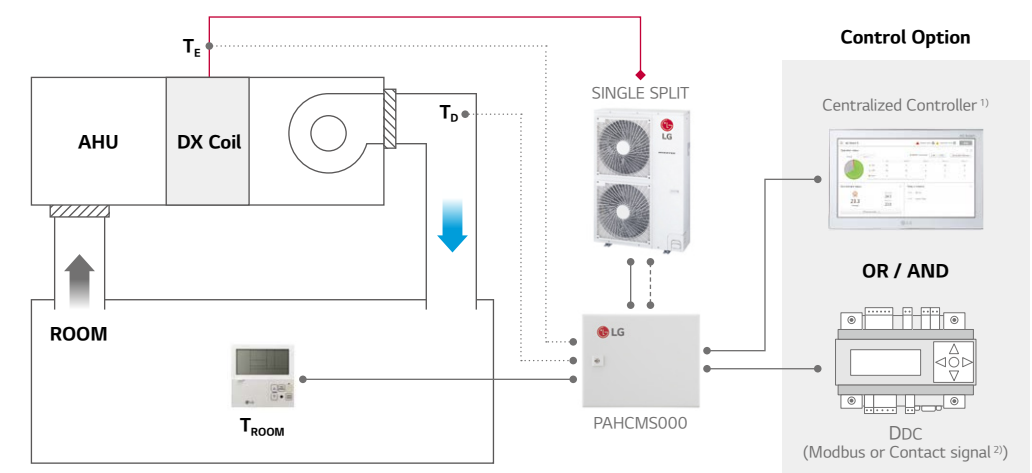
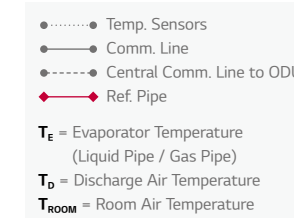

1) PI485 (PMNFP14A1) is required for centralized controller
2) In case of applying DDC with contact signal, discharge air temperature should be measured and controlled by DDC
Note : For more detail, please refer to the PDB

AHU KITS

Communication Kit Application

Small-Medium Capacity with Multi V + EEV Kit + IDU + Return / Room Air Temperature Control

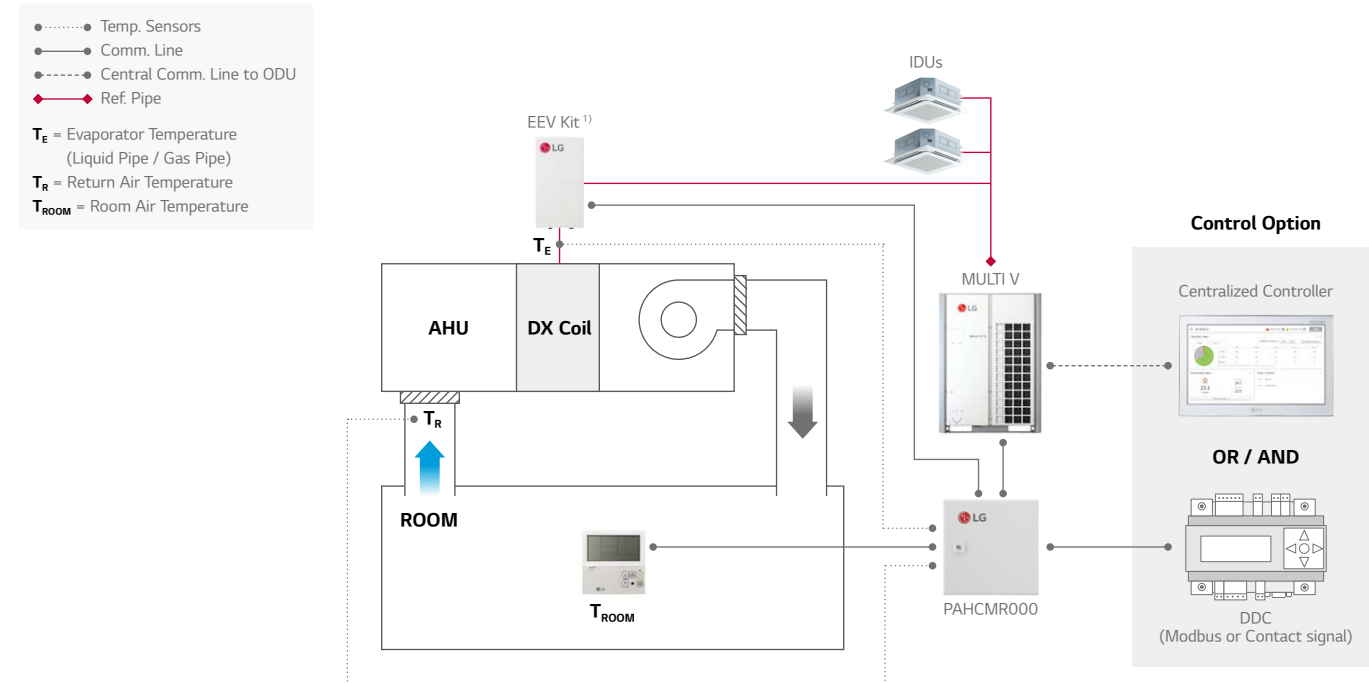

Communication Kit Application

Large Capacity with Multi V + TXV Kit + Return / Room Air Temperature Control

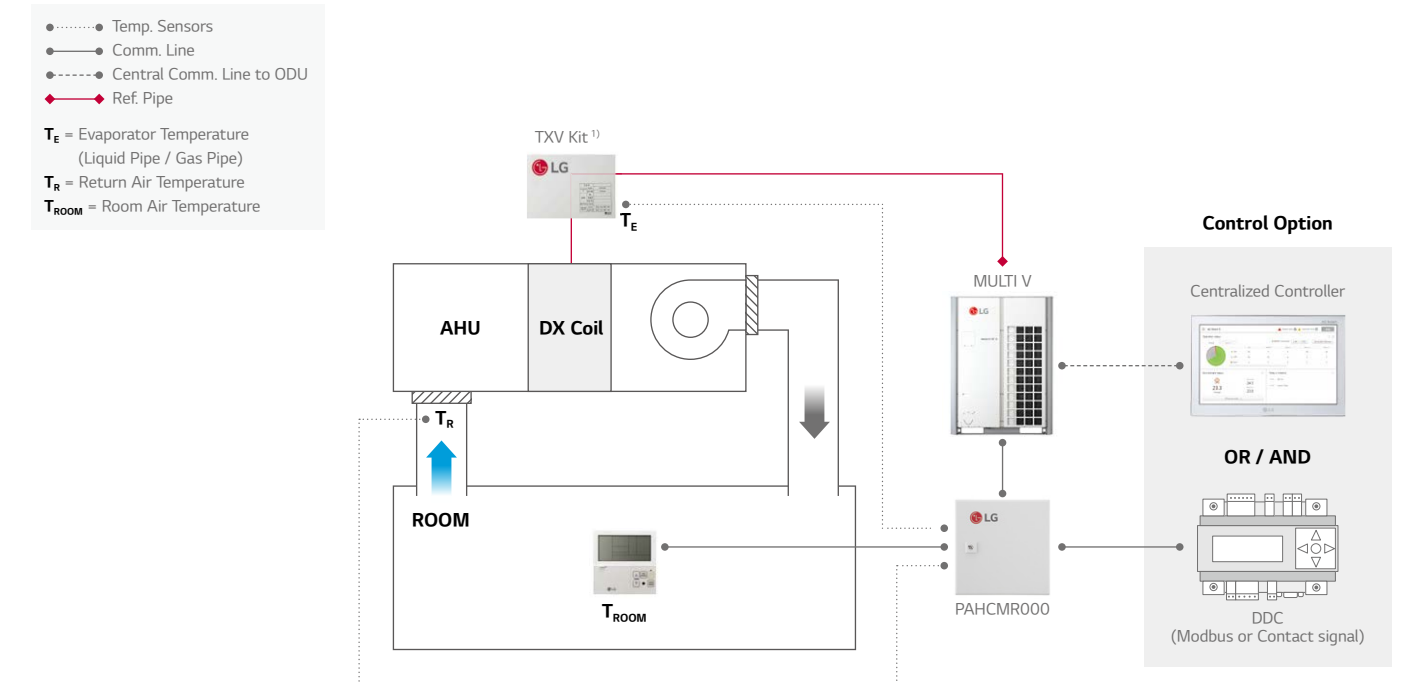

Small-Medium Capacity with Multi V + EEV Kit + Discharge Air Temperature Control

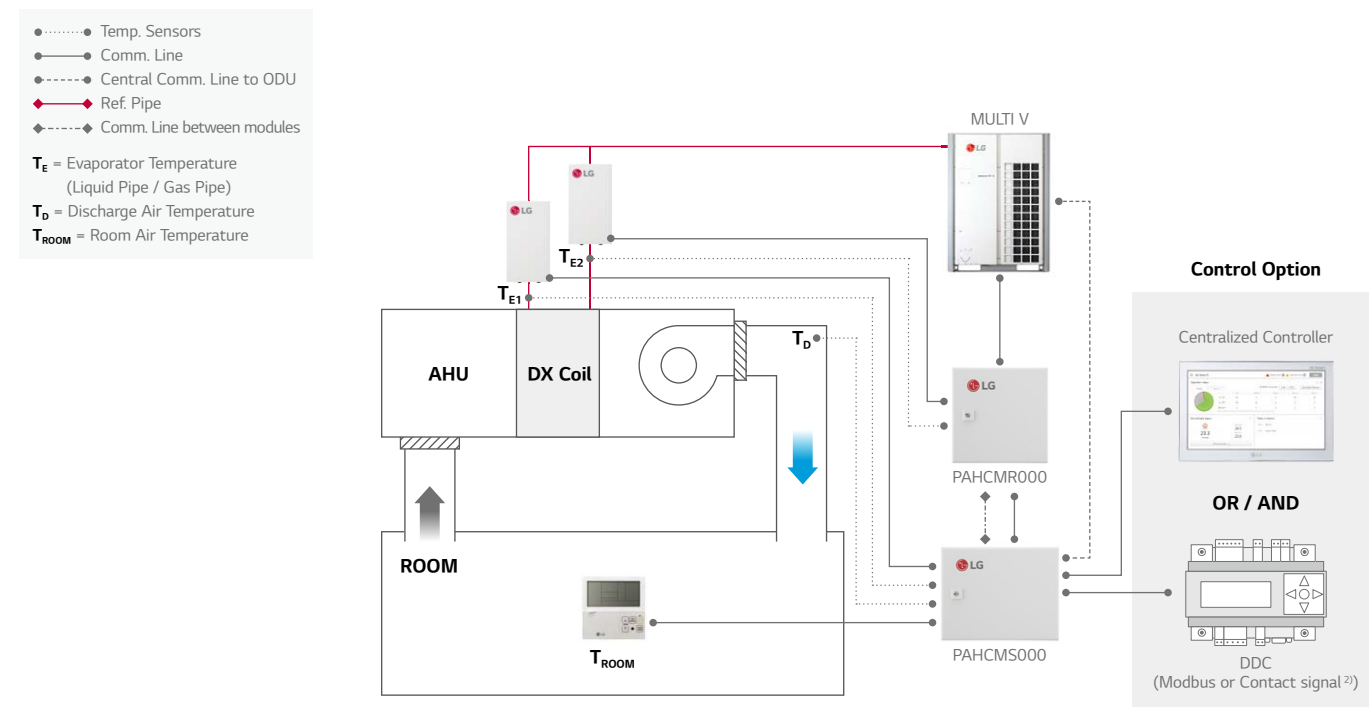

Large Capacity with Multi V + TXV Kit + Discharge Air Temperature Control

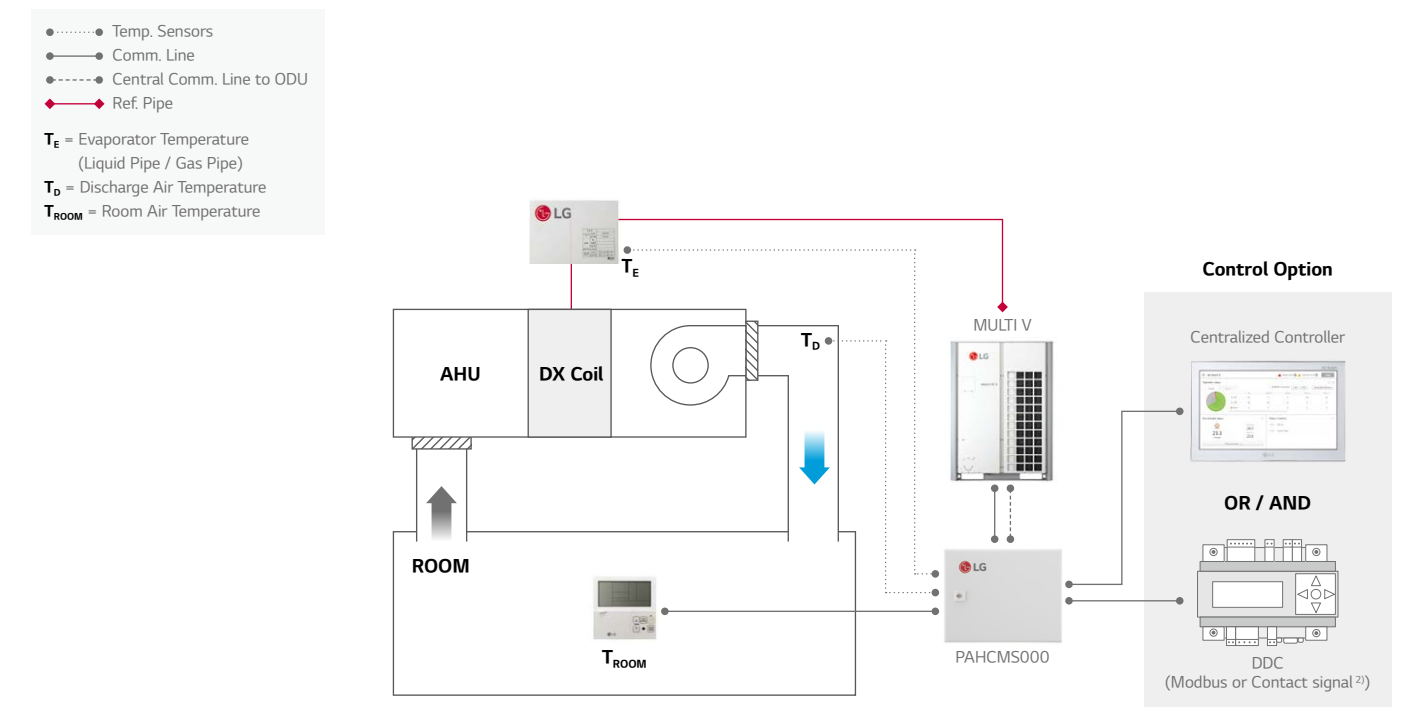

1) Multiple EEV kits can be applicable with multiple DX Coils and PAHCMR000s
 2) In case of applying DDC with contact signal, discharge air temperature should be measured and controlled by DDC
 Note : For more detail, please refer to the PDB

1) TXV Kit should be connected with outdoor unit 1:1
 2) In case of applying DDC with contact signal, discharge air temperature should be measured and controlled by DDC
 Note : For more detail, please refer to the PDB

Communication Kit Function

Communication with DDC via Contact Signal

Function List	PAHCMR000	PAHCMS000	Type	Electric Spec.
Comm. Kit Operation	On / Off		Digital Input	Non voltage
Operation Mode ¹⁾	Cooling / Heating		Digital Input	Non voltage
Return (room) Air Temperature ²⁾	16 - 30°C	-	Analog Input	DC 0 - 10V / 20mA
Discharge Air Temperature ³⁾	-	-	-	-
Fan Speed ⁴⁾	-	Low / Middle / High	Digital Input	Non voltage
Forced Thermal On / Off	On / Off	-	Digital Input	Non voltage
Capacity Control	-	○	Analog Input	DC 0 - 10V / 20mA
Comm. Kit Operation ²⁾	On / Off		Digital Output	Max. : DC 12V / 1A, AC 250V / 3A
Operation Mode	-		-	It needs to be checked through control signal
Return (room) Air Temperature	-	-	-	-
Discharge Air Temperature	-	-	-	-
Fan Speed ²⁾	Low / Middle / High	-	Digital Output	Max. : DC 12V / 1A, AC 250V / 3A
Defrost Operation ²⁾	Defrost / Normal	-	Digital Output	Max. : DC 12V / 1A, AC 250V / 3A
Error Alarm ²⁾	Error / Normal	-	Digital Output	Relay C contact (Max. : DC 30V / 5A, AC 250V / 5A)
Compressor On / Off	-	On / Off	Digital Output	Max. : DC 12V / 1A, AC 250V / 3A

※ ○ : Applied, - : Not Applied

1) Available operation mode can be varied depending on the setting of Communication Kit

2) This function may not be possible depending on the setting of Communication Kit. For more details, please refer to the product data book

3) Discharge air temperature should be controlled directly through DDC

4) To control the fan speed using contact signal, DO ports for the status of fan speed needs to be connected with the fan unit

Communication with DDC via Modbus protocol

Function List	PAHCMR000	PAHCMS000	Note
Comm. Kit Operation	On / Off		-
Operation Mode ¹⁾	Cooling / Heating		-
Return (room) Air Temperature	16 - 30°C	-	-
Discharge Air Temperature	-	16 - 30°C	-
Fan Speed ²⁾	Low / Middle / High	-	-
Forced Thermal On / Off	-	-	-
Capacity Control	-	○	-
Comm. Kit Operation	On / Off		-
Operation Mode ¹⁾	Cooling / Heating		-
Return (room) Air Temperature	-50 - 100°C	-	Corresponding air temperature sensor connected to AHU comm. kit is required
Discharge Air Temperature	-	-50 - 100°C	-
Fan Speed	Low / Middle / High	-	-
Defrost Operation	On / Off		-
Error Alarm	Error Alarm & Code		-
Compressor On / Off	On / Off		-

※ ○ : Applied, - : Not Applied

1) Available operation mode can be varied depending on the setting of Communication Kit

2) To control the fan speed using Modbus, DO ports for the status of fan speed needs to be connected with the fan unit

Note : For the Modbus memory map, please refer to the product data book

Communication Kit Function

With LG Control system (Individual & Centralized Controller)

Function List	PAHCMR000	PAHCMS000	Note
Comm. Kit Operation	On / Off	On / Off	-
Operation Mode ¹⁾	Cooling / Heating	Cooling / Heating	-
Return (room) Air Temperature	16-30°C	-	-
Discharge Air Temperature ²⁾	-	16 - 30°C	-
Fan Speed ³⁾	Low / Middle / High	-	-
Forced Thermal On / Off	-	-	-
Capacity Control	-	-	-
Comm. Kit Operation	On / Off	On / Off	-
Operation Mode ¹⁾	Cooling / Heating	Cooling / Heating	-
Return (room) Air Temperature	11-39.5°C / -50-100°C	-	By Individual controller : 11 - 39.5°C By Centralized controller : -50 - 100°C
Discharge Air Temperature	-	-50 - 100°C	Only with Centralized Controller
Fan Speed ³⁾	Low / Middle / High	-	-
Defrost Operation	On / Off	On / Off	Only with Individual Controller
Error Alarm	Error Code	Error Code	-
Compressor On / Off	On / Off	On / Off	Only with Individual Controller

※ ○ : Applied, - : Not Applied











1) Available operation mode can be varied depending on the setting of Communication Kit. For more details, please refer to the product data book

2) This range may differ depending on the type of controller

3) To control the fan speed using contact signal, DO ports for the status of fan speed needs to be connected with the fan unit

Note : Control function is unavailable in case of using together with DDC via contact signal

Compatibility with LG HVAC Controllers

Controller	Individual Controller			Centralized Controller				BMS Gateway	PDI	
	Premium	Standard III	Standard II	AC Ez	AC Ez Touch	AC Smart 5	ACP 5	AC Manager 5 ¹⁾	ACP Lonworks	Premium Standard
										
Model no.	PREMTA000 PREMTA000A PREMTA000B	PREMTB100 PREMTBB10	PREMTB001	PQCSZ250S0	PACEZA000	PAC5A000	PACP5A000	PACM5A000	PLNWK000	PQNUD1S40 PPWRDB000
PAHCMR000	○	○	○	○	○	○	○	○	○	○
PAHCMS000	-	-	○ ²⁾	-	-	○	○	○	-	-

※ ○ : Applied, - : Not Applied

1) AC Manager 5 is an integrator, so the installation with AC Smart 5 or ACP 5 is required

2) Set temperature range of this model shall be extended in the future

Note : 1. Dry contact for indoor unit (PDRYCB000 / 400 / 300 / 500) is not applied

2. For more details, please refer to the product data book

AHU KITS

Communication Kit Function

Outdoor Unit Compatibility

Multi V

Model		MULTI V				MULTI V WATER		
		S	IV	III	S	IV	II	S
AHU Controller	PAHCMR000	○	○	○	○	○	○	○
	PAHCMS000	○	○	○	○	○	○	-

Single Split

Standard Inverter (1-phase)									
Capacity	Cooling	kW	4.7	7.7	8.0	10.0	12.5	13.9	14.6
	Heating	kW	5.5	8.0	9.0	11.0	14.0	15.4	16.9
AHU Kit	PAHCMR000		○	○	○	○	○	○	○
	PAHCMS000		○	○	○	-	-	-	-

Standard Inverter (3-phase)								
Capacity	Cooling	kW	10.0	12.5	13.9	14.6	19.0	23.0
	Heating	kW	11.0	14.0	15.4	16.9	22.4	27.0
AHU Kit	PAHCMR000		○	○	○	○	○	○
	PAHCMS000		-	-	-	-	○	○

※ ○ : Applied, - : Not Applied
 Note : 1. Table of the outdoor unit compatibility is based on European regional model.
 2. When connecting outdoor units in other areas, please check whether they are compatible or not.

Expansion valves for MULTI V system

EEV Kit	PRLK048A0															PRLK096A0				
	1.3	1.6	2	2.5	3	3.5	4	5	6	8	10	12	14	16	18	20				
HP	3.6	4.5	5.6	7.1	8.2	10.6	12.3	14.1	15.8	22.4	28	33.6	39.2	44.8	50.4	56				
Cooling (kW)	4	5	6.3	8	9.2	11.9	13.8	15.9	18	25.2	31.5	37.8	44.1	50.4	56.7	63				
Heating (kW)																				

TXV Kit	PATX13A0E				PATX20A0E				PATX25A0E				PATX35A0E				PATX50A0E			
	8 - 16	18 - 26	28 - 36	38 - 46	48 - 56															
HP	22.4 - 44.8	50.4 - 72.8	78.4 - 100.8	106.4 - 128.8	134.4 - 156.8															
Cooling (kW)	25.2 - 50.4	56.7 - 81.9	88.2 - 112.1	118.4 - 143.6	148.5 - 175.1															
Heating (kW)																				

* Capacities are based on the following conditions :
 - Cooling : Indoor 27°C (80.6°F) DB / 19°C (66.2°F) WB Outdoor 35°C (95°F) DB / 24°C (75.2°F) WB
 Condensing temperature (tc) 46°C, Evaporating temperature (te) 6°C
 - Heating : Indoor 20°C (68°F) DB / 15°C (59°F) WB Outdoor 7°C (44.6°F) DB / 6°C (42.8°F) WB
 Hot gas inlet temperature 70°C, Condensing temperature (tc) 46°C
 - Piping Length : Interconnected Pipe Length = 7.5m
 - Difference Limit of Elevation (Outdoor - Indoor Unit) is zero

Control Kit

List	Required Item
Heating / Cooling	SA / RA temperature sensor (or SA / RA temperature & humidity sensor)
Automatic Ventilation	SA / RA temperature, CO ₂ sensor, Damper actuator (OA, EA, MA)
Energy Saving (Cooling Mode Only)	SA temperature, OA / RA temp&humidity sensor, Damper actuator (OA, EA, MA)
Humidification	SA temperature, RA temperature & humidity sensor, Humidifier
Inverter Fan Control	SA / RA temperature, Static pressure sensor, Inverter driver for fan control
Filter Alarm	Difference pressure sensor
Smoke Detecting	Smoke detection sensor

RA : Return Air, EA : Exhaust Air, OA : Outdoor Air, SA : Supply Air, MA : Mix air (RA + OA)

Field Supplied Item

List	Required Specification	Apply Location
Temperature Sensor	- Power : AC 24V, Output signal : DC 0 - 10V - Temperature boundary : -50 - 50°C	- Apply to MA, SA, RA
Temperature & Humidity Sensor	- Power : AC 24V, Output signal : DC 0 - 10V - Temperature boundary : -40 - 70°C - Humidity boundary : 0 - 95% RH	- Apply to SA, RA, OA - Can not be applied to MA
Damper Actuator	- Power : AC 24V, In/Output signal : DC 0 - 10V - Torque : 15 Nm, Operation time : 150sec. - Rotation angle : 90°	- Apply to OA, EA, MA damper
Difference Pressure Sensor (for Filter)	- Power : AC 24V, Output signal : DC 0 - 10V * Boundary : 0 - 1000Pa - Switch type : Relay Open / Close	- Apply to filter
Static Pressure Sensor	- Power : AC 24V, Output signal : DC 0 - 10V - Boundary : 0 - 1000pa	- Apply to SA (for inverter control)
CO ₂ Sensor	- Power : AC 24V, Output signal : DC 0 - 10V - Boundary : 0 - 2000ppm	- Apply to RA duct
Smoke Detection Sensor	- Power : AC 24V, From : Contact point type	- Apply to RA duct

Note : Boundary of specification can be changed through LGAV software. However, please make a specification referring to the above table

Various Control with Control kit – Multiple MULTI V + TXV Kits

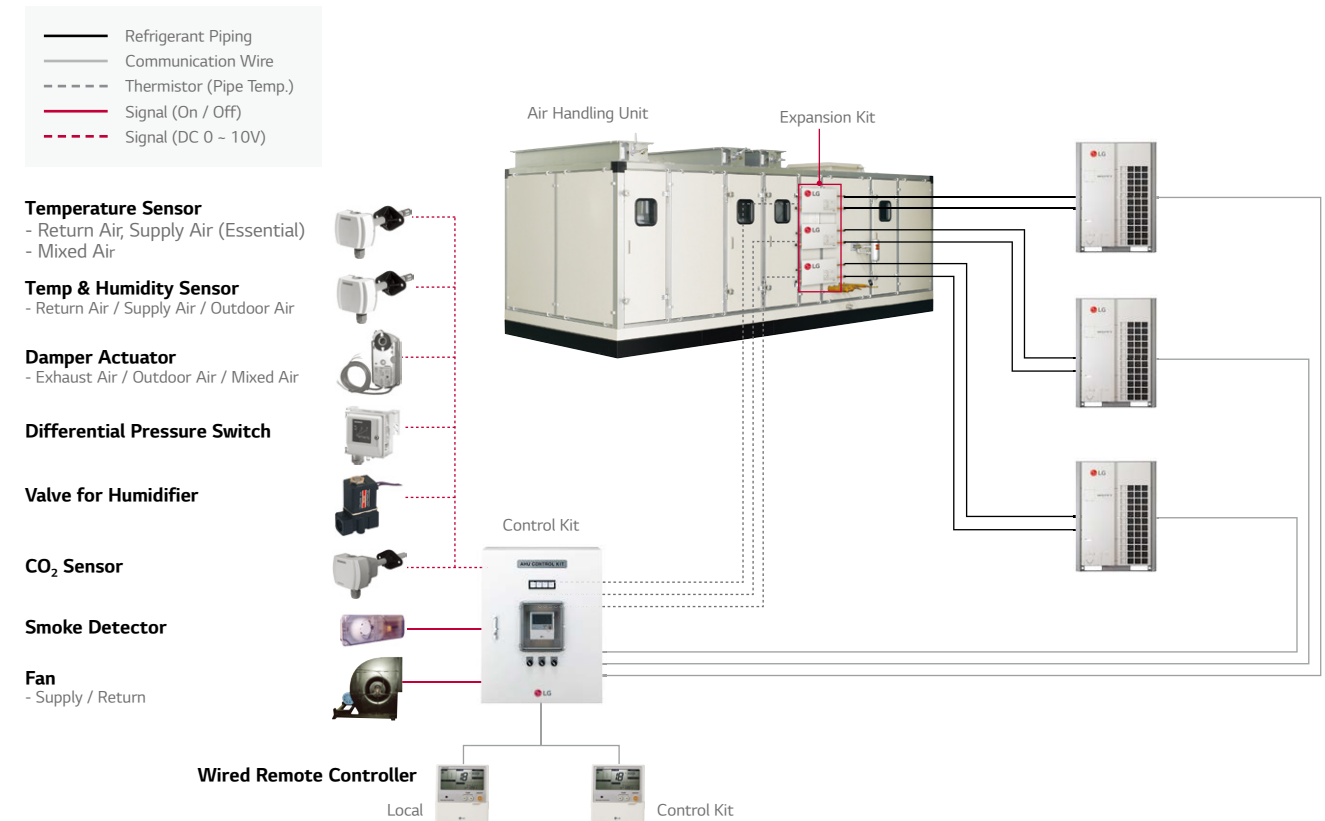

HOTEL

Hotel Control Solution



Guest Rooms

- The air conditioner automatically turn off when guests leave
 Dry contact
- Integrated control of air conditioner with the hotel room controller
 Dry contact
- Control the air conditioner with an existing hotel thermostat
 Dry contact For thermostat
- Guest safety is the first priority
 Refrigerant Leak detector







Reception

- Air conditioner control in conjunction with check-in or check out
 AC Smart 5 (Schedule)

Public Areas

- Centralized management of the public areas

Hotel Proposal / Design

Guest Room				Lobby
<p>The air conditioner automatically turn off when guests leave</p>  <p>PDRYCB400 2 contact point</p> <p>Input</p> <ul style="list-style-type: none"> Operation On / Off <p>Output</p> <ul style="list-style-type: none"> Operation On / Off status Error alarm 	<p>Integrated control of air conditioner with the hotel room controller</p>  <p>PDRYCB500 Modbus RTU(9,600bps)</p> <p>Function</p> <ul style="list-style-type: none"> Operation Indoor temperature Error alarm Set run mode Set temperature Set fan speed 	<p>Control with existing hotel thermostat</p>  <p>PDRYCB300 8 contact point</p> <p>Input</p> <ul style="list-style-type: none"> Operation On / Off Thermo On / Off Operation mode (Fan / Heat / Cool) Fan speed (Low / Middle / High) <p>Output</p> <ul style="list-style-type: none"> Operation On / Off status Error alarm 	<p>Guest safety is the first priority</p>  <p>PRLDNV50 Refrigerant leakage detector</p> <ul style="list-style-type: none"> 6000ppm  <p>PREMTB100 Wired remote controller</p> <ul style="list-style-type: none"> 4.3 inch color LCD Touch button 	<p>Air conditioner control in conjunction with check-in or check out</p>  <p>PACS5A000 AC Smart 5</p> <ul style="list-style-type: none"> BMS Integration (BACnet IP, Modbus TCP)  <p>PACP5A000 ACP 5</p> <ul style="list-style-type: none"> BMS Integration (BACnet IP, Modbus TCP)

SHOPPING MALL

Shopping Mall Control Solution



Retail

- Rationally distribute and manage the power consumption by tenants
 PDI
- Fast problem detection and alarms
 Central controller (Operation trend)







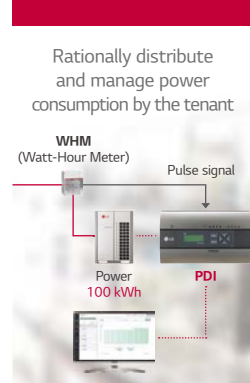

Maintenance Office

- Reduces energy by checking operational trends
 Central controller (Operation trend)

Atrium

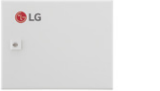
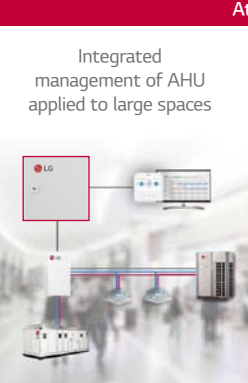
- Integrated management of AHU applied to large spaces
 Comm. Kit
- Chiller and VRF integrated control
 Central controller (Operation trend) +  Chiller option kit

Shopping Mall Reference

Retail	Maintenance Office	Atrium
<p>Rationally distribute and manage power consumption by the tenant</p>  <p>PPWRDB000 PDI Standard (2 port)</p> <ul style="list-style-type: none"> Max. 128 IDU  <p>PQNUD1S40 PDI Premium (8 port)</p> <ul style="list-style-type: none"> Max. 128 IDU 	<p>Fast problem detection and alarms</p>  <p>PACS5A000 AC Smart 5</p> <ul style="list-style-type: none"> BMS Integration (BACnet IP, Modbus TCP)  <p>PACP5A000 ACP 5</p> <ul style="list-style-type: none"> BMS Integration (BACnet IP, Modbus TCP) 	<p>Reduces energy by checking operational trends</p>  <p>PAHCMR000 AHU Comm. Kit</p> <ul style="list-style-type: none"> Return air  <p>PAHCMS000 AHU Comm. Kit</p> <ul style="list-style-type: none"> Discharge air
		<p>Integrated management of AHU applied to large spaces</p>  <p>PAHLLN000 Chiller option kit</p> <p>+  PACP5A000 ACP 5 +  PACS5A000 AC Smart 5</p> <p>Chiller and VRF integrated control</p>  <p>PCHLLN000 Chiller option kit</p>

HOSPITAL

Hospital Control Solution

Hospital Ward

- Proper airflow management for patients
- Monitor the comfort level for each hospital ward
- Control fan speed and air volume

Service Zone

- Energy savings based on flexible scheduling

Lobby

- Centralized management of AHU for large spaces

Wired remote controller
Central controller (Comfort level)
Dry contact
Central controller (Schedule)
Comm. Kit

Hospital Proposal / Design

Hospital Ward			Service Zone	Lobby
Proper airflow management for patients	Monitor the comfort level for each hospital ward	External device interlock control	Energy savings based on flexible scheduling	Centralized management of AHU for large space
PTVSM40 Human detection sensor	PACS5A000 AC Smart 5	PDRYCB400 2 contact point	PACS5A000 AC Smart 5	PAHCMR000 AHU Comm. Kit
	• BMS Integration (BACnet IP, Modbus TCP)	Input • Operation On / Off	• BMS Integration (BACnet IP, Modbus TCP)	• Return air
		Output • Operation On / Off status • Error alarm		
PREMTB100 Wired remote controller	PACP5A000 ACP 5		• BMS Integration (BACnet IP, Modbus TCP)	PAHCM5000 AHU Comm. Kit
• 4.3 inch color LCD • Touch button	• BMS Integration (BACnet IP, Modbus TCP)			• Discharge air

EDUCATION

Education Control Solution

Class Room

- Automatically save energy in the absence of students
- Central controls prevent students from arbitrary control

Lecture Room

- Schedule management according to academic plan

Maintenance Office

- Integrated management of distributed buildings
- Centralized management with multiple interfaces

Wired remote controller
Central controller (Lock)
Central controller (Schedule)
Central controller (Multiple management)
Central controller (HTML5)

Education Proposal / Design

Class Room		Lecture Room	Maintenance Office	
Automatically save energy in the absence of students	Central controls prevent students from arbitrary control	Schedule management according to academic plan	Integrated management of distributed buildings	Centralized management with multiple interfaces
PTVSM40 Human detection sensor	PREMTB100 Wired remote controller	PACS5A000 AC Smart 5	PACP5A000 ACP 5	PACM5A000 AC Manager 5
	• 4.3 inch color LCD • Touch button	• BMS Integration (BACnet IP, Modbus TCP)	• BMS Integration (BACnet IP, Modbus TCP)	

Office Control Solution

Maintenance Office

Energy savings and management throughout the building

Integrated management of HVAC with BMS system

Reduce costs by replacing BMS

Office Room

Reasonable power distribution to tenants

Server Room

Main equipment 24 hours back up management

Meeting Room

Energy savings based on occupancy detection

Central controller (Energy Nav)

Central controller (BMS Gateway)

Central controller (Operation trend) + ACS IO Module

PDI

Central controller (Backup operation)

Wired remote controller

Residential Control Solution

Home

Control your home air conditioner anytime, anywhere

Living Room

Build a smart house

Bed Room

Use a familiar residential thermostat

Apartment / Residence

Stable system operation

Wi-Fi Modem

Modbus RTU

Dry contact For thermostat

Wired remote controller

Independent power module

Office Proposal / Design

Maintenance Office	Office Room	Server Room	Meeting Room
<p>Energy savings and management throughout the building</p> <p>Integrated management of HVAC with BMS system</p> <p>Reduce costs by replacing BMS</p>	<p>Reasonable power distribution to tenants</p>	<p>Main equipment 24 hours back up management</p>	<p>Energy savings based on occupancy detection</p>
<p>BMS Protocol</p> <p>BACnet, Modbus</p> <p>BMS System</p> <p>SIEMENS, Honeywell, Johnson Controls</p>	<p>WHM (Watt-Hour Meter)</p> <p>Pulse signal</p> <p>Power 100 kWh</p> <p>PDI</p>	<p>Error</p> <p>24 HOURS</p>	<p>Human detection sensor</p>
<p>PACS5A000 AC Smart 5</p> <p>• BMS Integration (BACnet IP, Modbus TCP)</p> <p>PLNWKB000 LonWorks gateway</p> <p>PEXPMB000 ACS IO Module</p>	<p>PPWRDB000 PDI Standard (2 port)</p> <p>• Max. 128 IDU</p> <p>PQNUD1S40 PDI Premium (8 port)</p> <p>• Max. 128 IDU</p>	<p>PACS5A000 AC Smart 5</p> <p>• BMS Integration (BACnet IP, Modbus TCP)</p> <p>PACP5A000 ACP 5</p> <p>• BMS Integration (BACnet IP, Modbus TCP)</p>	<p>PTVMA0 Human detection sensor</p> <p>PREMTB100 Wired remote controller</p> <p>• 4.3 inch color LCD • Touch button</p>
<p>PACP5A000 ACP 5</p> <p>• BMS Integration (BACnet IP, Modbus TCP)</p> <p>PMBUSB00A Modbus RTU gateway</p> <p>PEXPM300 PEXPM200 PEXPM100 ACU IO Module</p>			

Residential Proposal / Design

Home	Living Room	Bed Room	Apartment
<p>Control your home air conditioner anytime, anywhere</p>	<p>Build a Smart house</p>	<p>Use a familiar residential thermostat</p>	<p>Stable system operation when indoor unit power is lost</p>
<p>PWFMD200 LG Wi-Fi modem</p>	<p>PDRYCB500 Modbus RTU (9,600bps)</p>	<p>PDRYCB300 8 contact point</p>	<p>PRIPO Independent power module</p> <p>• EEV full close function</p>
<p>Function</p> <ul style="list-style-type: none"> • On / Off • Fan speed • Operation mode • Vane control • Reservation (Sleep, Weekly On / Off) • Error check 	<p>Function</p> <ul style="list-style-type: none"> • Operation • Indoor temperature • Error alarm • Set operation mode • Set temperature • Set fan speed 	<p>Input</p> <ul style="list-style-type: none"> • Operation On / Off • Thermo On / Off • Operation mode (Fan / Heat / Cool) • Fan speed (Low / Middle / High) <p>Output</p> <ul style="list-style-type: none"> • Operation On / Off status • Error alarm 	

ACCESSORIES

MECHANICAL ACCESSORIES / PIPING ACCESSORIES



CASSETTE PANEL

Stylish designed panels make more unique space by various applications

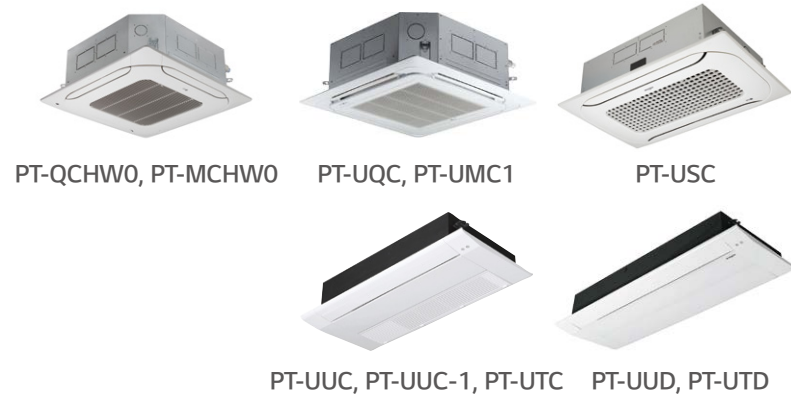

Model Name & Applied Products

- 4 Way Cassette
 - PT-MCHW0
 - PT-QCHW0
 - PT-UQC / PT-UMC1
- 2 Way Cassette
 - PT-USC
- 1 Way Cassette (Grill Type)
 - PT-UUC / PT-UUC1 / PT-UTC
- 1 way cassette (Panel Type)
 - PT-UUD / PT-UTD

Key Features

- Independent vane operation uses separate motors, making it Possible to control all 4 vanes independently.
- The detachable corner design makes it easy to adjust the hanger during installation and to check for leakages in the drain pipe and refrigerant pipes.

Compact and Stylish Design

- New 4 way cassette panel adapted unibody shape and matching with into the ceiling
- Panel size is fit into the ceiling tile

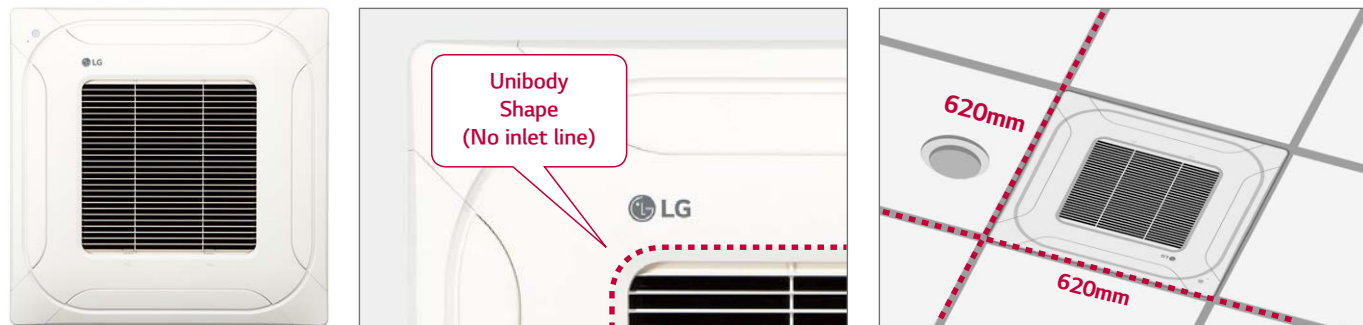

Specification

Model	Suction Type	Color (RAL)	Gloss	Weight (kg)	Dimension (mm)			Applied model capacity (kW)*					
					W	H	D	Single Split		Multi Split		Multi V	
								R32	R410A	R32	R410A	R410A	
4 way	PT-QCHW0	Grill	Morning Fog (RAL 9001)	-	3.0	620	35	620	2.5 - 5.0	2.5 - 5.0	1.5 - 5.3	1.5 - 5.3	1.6 - 6.2
	PT-MCHW0	Grill	Morning Fog (RAL 9001)	-	6.3	950	35	950	6.8 - 14.6	6.8 - 14.6	6.7	-	7.1 - 15.8
	PT-UQC	Grill	Morning Fog (RAL 9001)	-	3.0	700	22	700	2.5 - 5.0	2.5 - 5.0	-	1.5 - 5.3	1.6 - 6.2
	PT-UMC1	Grill	Morning Fog (RAL 9001)	-	5.6	950	25	950	6.8 - 14.6	6.8 - 14.6	-	6.7	7.1 - 15.8
2 way	PT-USC	Grill	Morning Fog (RAL 9001)	-	4.7	1,100	28	690	-	-	-	-	2.8 - 7.1
	PT-UUC	Grill	Noble White (RAL 9003)	○	4.6	1,100	34	500	-	-	-	-	2.2 - 3.6
1 way	PT-UUC1	Grill	Noble White (RAL 9003)	-	4.4	1,100	34	500	-	-	2.6 - 3.5	2.6 - 3.5	-
	PT-UTC	Grill	Noble White (RAL 9003)	○	5.5	1,420	34	500	-	-	-	-	5.6 - 7.1
	PT-UUD	Panel	Noble White (RAL 9003)	○	4.6	1,100	34	500	-	-	-	-	2.2 - 3.6
	PT-UTD	Panel	Noble White (RAL 9003)	○	5.5	1,420	34	500	-	-	-	-	5.6 - 7.1

* Based on cooling capacity
 ※ ○ : Applied, - : Not applied

CASSETTE COVER

Cover in case of exposed cassette installation

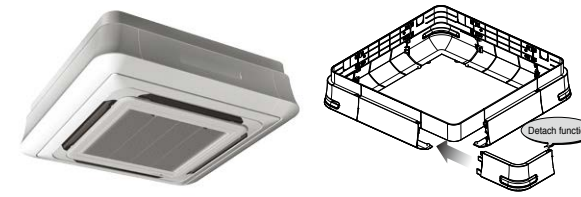

Model Name

PTDCM / PTDCQ

Applied Products

4 Way Cassette (for chassis TP, TN, TM, TQ, TR)

Key Features

- Specially designed for indoor unit
- Covers the side area of cassette
- Gives elegant looks
- Light weight

Included Parts

- Cover A, Cover B
- Cover C, Cover D
- Screws
- Installation Manual

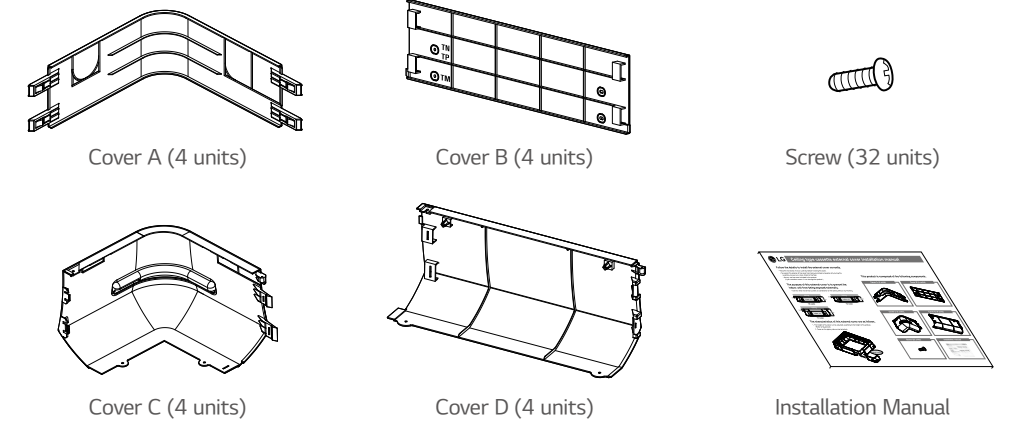

Specification

Model	Front Panel	Weight (kg)		Dimensions (mm)			
		NET	Gross	W	H	D	
PTDCM	PT-UMC / PT-UMC1	TP / TN	5.9	8.8	1,157	1,157	268
		TM	5.9	8.8	1,157	1,157	310
PTDCQ	PT-UQC	TR	5.0	7.2	907	907	268
		TQ	5.0	7.2	907	907	310

CO₂ SENSOR

CO₂ sensor in ventilation system

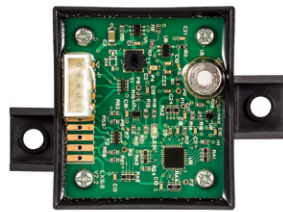

Model Name

AHCS100H0

Applied products

LZ-H025GBA4
LZ-H035GBA5 / LZ-H050GBA5 / LZ-H080GBA5
LZ-H100GBA5 / LZ-H150GBA5 / LZ-H200GBA5

Applicable products

LZ-H050GXN0 / LZ-H080GXN0 / LZ-H100GXN0
LZ-H050GXH0 / LZ-H080GXH0 / LZ-H100GXH0

Dimensions

(unit : mm)

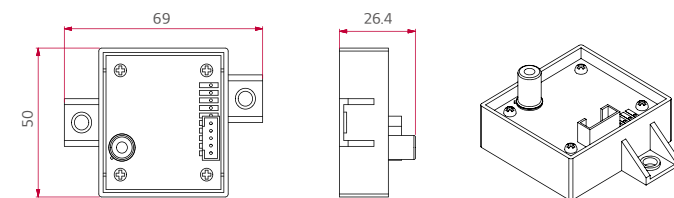

Key Features

Specification

- Applied Model : ERV (Embedded), ERV DX (Option)
- Supply voltage : DV12V ± 5%
- Output : 0.6 ~ 4.4V (Linear output, 240 ~ 1,760 ppm CO₂)
- Accuracy : ± 10% (2 days after installation)

Description

- The product is especially designed to detect CO
- This model requires Standard III Wired Remote Controller for display

Key Application

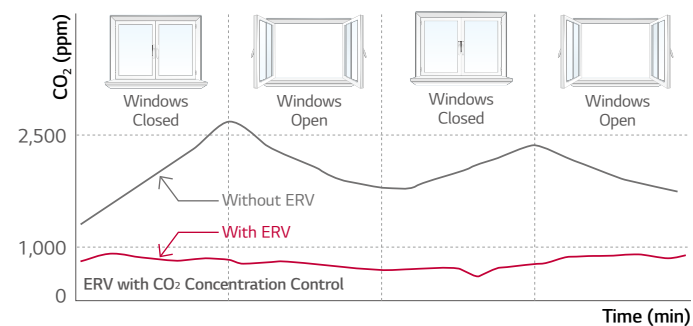
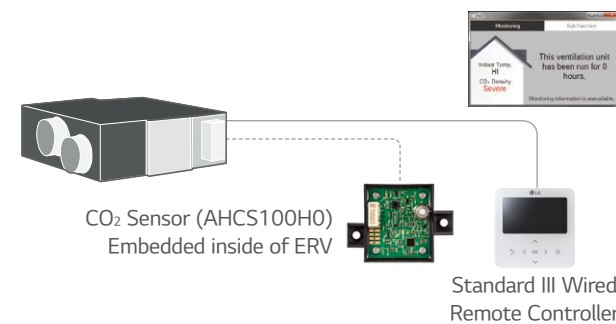

How to Install

1. Remove a screw on the service cover. Pull the service cover fixing bracket (①), then remove the service cover (②). Remove two elements (③) and two air filters (④).
2. Install the sensor with two screws.
3. Remove a screw, then remove the right side of element rail (⑤).
4. Press the holder (⑥) into the hole to fix the CO₂ sensor cable (⑦).
5. Connect the wire terminal to the CN-CO₂ port of PCB.

※ Airflow can be controlled by concentration of CO₂, after setting automatic operation mode at remote controller. ※ Use the screwdriver whose total length is less than 250mm.

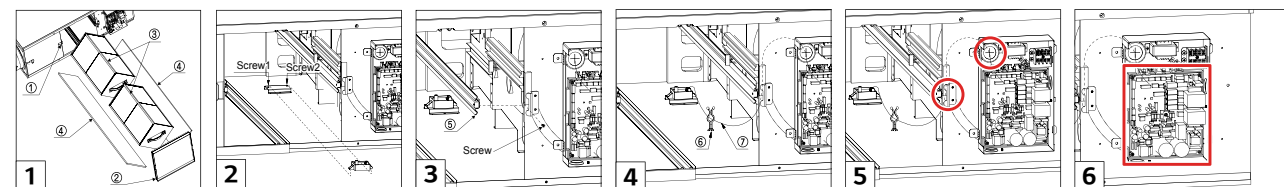

REFRIGERANT LEAKAGE DETECTOR

R410A refrigerant leakage detector makes our space safer



Model Name

PRLDNVSO

Applied Products

Multi V 5
Multi V IV Heat Pump & Heat Recovery
Multi V Water IV

Key Features

- This detector senses refrigerant leakage when the refrigerant concentration exceeds 6,000ppm. (The green and red LED lights blink simultaneously.)
- Alarm is "ON" over 6,000ppm has been maintained 5 seconds, and Alarm is "OFF" under 6,000ppm has been maintained 5 seconds.
- When the alarm of the refrigerant leak detector is switched on the user must ventilate the room until the alarm is disabled.
- The detector has to be installed inside the room and it should be installed 300 ~ 500mm above the floor.

Specification

Parts	Specifications	
Sensor	Rated Voltage (V)	DC 5.0 ±5%
	Dimensions (W x H x D, mm)	31 x 44 x 20
	Weight (g)	22
	Detectable Refrigerant	R410A
	Detected concentration (ppm)	0 / 6,000 Alarm Off / On
	Operating temperature range (°C)	-10 ~ 50
	Preserved temperature range (°C)	-40 ~ 60
Connecting Cable	Cable length (m)	10
	Dimensions of Front Plate (W x H x D, mm)	80 x 110 x 44.6
Sensor Protective Cover	Dimension of Backplate (W x H x D, mm)	80 x 110 x 6.5

This function available for ARU****L*5 and 4 (Multi V 5, Multi V IV H/P, H/R model)

Included Parts

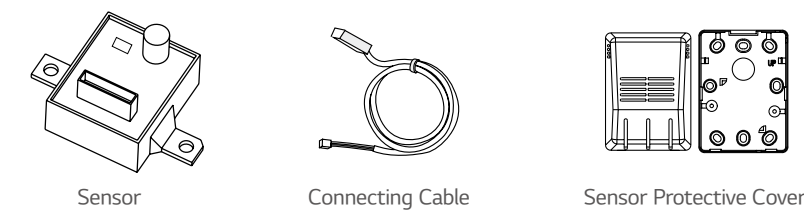

Key Application

Refrigerant Leakage Detector has three application methods.

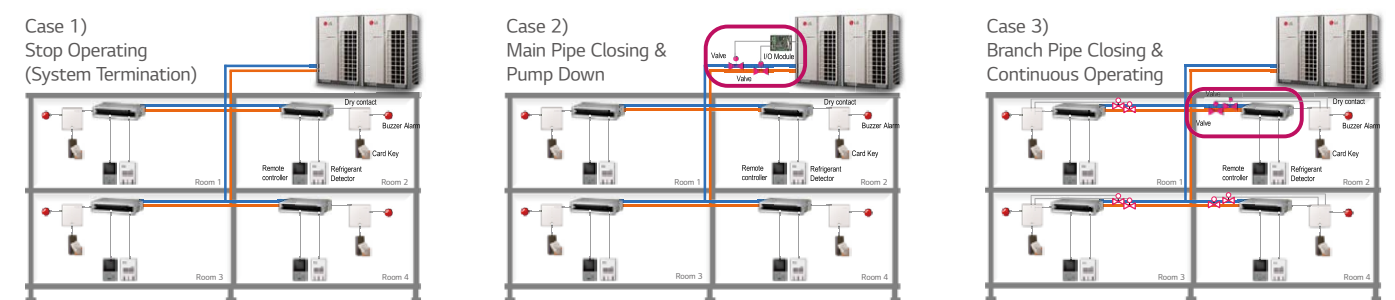

Accessory Specification (To realize the case 2 application)



EEV KIT

MULTI V EEV KIT is specially designed to reduce noise and make comfort environment



Model Name

PRGK024A0

Applied Products

Indoor Unt	Model	Chassis	Applicable	Indoor Unt	Model	Chassis	Applicable	
Cassette	1 Way Cassette	TU	○	Etc	Floor Standing	CE	○	
	2 Way Cassette	TT	N/A		Convertible	VE	○	
	4 Way Cassette	TS	○(-5.6kW)		○	Ceiling Suspended	V1	-
		TR	○		○	Wall Mounted	V2	-
		TQ	○(-4.5kW)		○	SJ	○	
		TP	N/A		○	SK	○	
	Duct	High Sensible	TN		N/A	SV	-	
			TM		-	Art Cool	SF	○
			BG		-	Console	QA	○
		High Static	BR		-	Hydro kit	K2	-
B8			-	K3	-			
Middle Static		M1	○(-5.6kW)	※ ○: Applied, -: Not applied, N/A: Not Applicable				
		M2	-					
		M3	-					
Low Static		L1	○					
		L2	-					
		L3	-					

Key Features

- Decreasing noise level of Multi V Indoor units and easy installation

Key Application

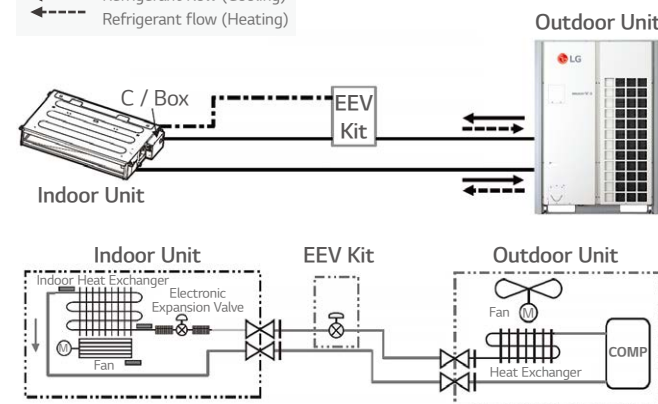
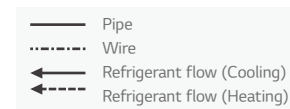

EEV Kit can be applied for the space which requires quiet and noise-sensitive



Note : If you don't use EEV of same specification, Cooling (Heating) capacity could be decreased.

How to Install

Open Indoor unit's control box cover.

- Open fully indoor unit's EEV through vacuum mode of ODU setting.
- Detach the Indoor unit's EEV connector from PCB and then push the reset button of Outdoor unit's PCB
- After connecting indoor unit's EEV CONNECTOR, repeat the process ① & ②. Then, connect the EEV CONNECTOR of EEV KIT in PCB of indoor unit.
- Finally connect the lead wire of the EEV Kit to the indoor unit's PCB.
- Assemble the control box cover.

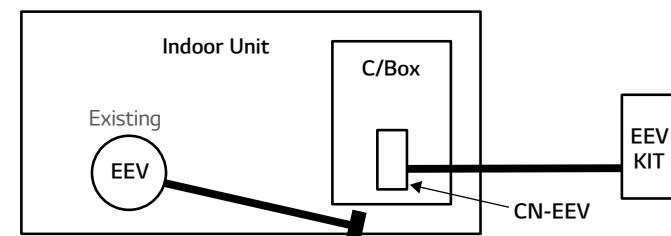

IR RECEIVER

IR RECEIVER can be connected to ceiling concealed duct and floor standing unit which the customer wants to control by wireless remote controller



Model Name

PWLRVN000

Applied Products

Multi V Indoors (Ceiling Concealed Duct, Floor Standing Units)

Key Features

- Designed for wireless control
- Indication lamps (3 colors) and Self-diagnosis function

Key Application

Note : Do not install both the IR Receiver and Wired Remote Controller. This may cause malfunctions.

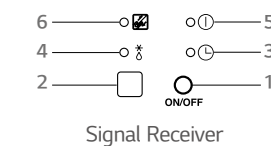
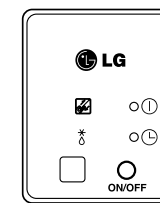
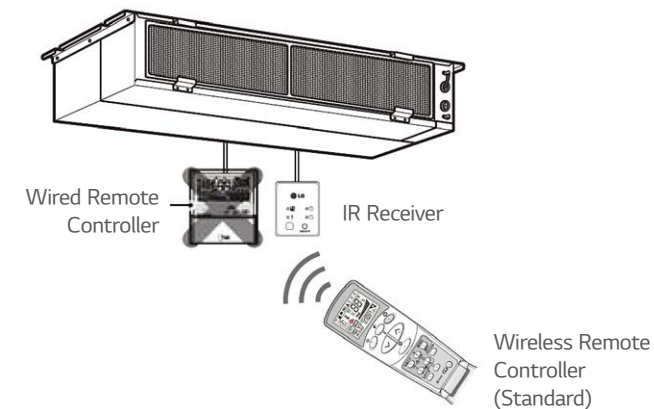

Operation of Indication Lamps

- Emergency Operation button :**
Turns the indoor unit on or off when remote controller is not working.
- Signal Detector :**
Receives the signal from remote controller.
- Timer lamp (Green) :**
Lights up during the timer operation.
- Hotstart lamp (Orange) :**
Lights up during the pre-heating operation, defrost operation as well as latent heat removal operation in heat mode. Available only for the heat pump models, not cooling only models.
- System On/Off lamp (Red) :**
Lights up during system controller operation.
- Filter Sign lamp (Green) :**
Lights up after 2,400 hours from the time of first power on operation.

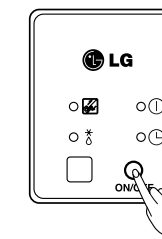

Test Run Mode

After installing the product, you must run a Test Run mode. Press the Emergency Operation button for 5 seconds, until the LED flickers. Then the indoor unit, duct runs cooling mode for 18 minutes, where the setting temperature is 18°C and the fan speed is high.

INDEPENDENT POWER MODULE

EEV fully close function in case of power cut



Model Name

PRIPO

Applied Products

Multi V Indoor Units

Key Features

- Independent Power Module is specially designed to close the Indoor EEV when power cut-off.
- Supply Voltage : DC 12V ± 50%

Included Parts

Model	PRIPO		
Item	Independent Power Kit	Screw	Clamp (Tie Wrap)
Q'ty	1	2	4
Figure			

(Others)

- Harness 1 (1m)
- Harness 2 (1m)
- Harness 3 (1m)
- Installation Manual
- Insulation (PE)

Key Application

If the EEV is opened due to power cut off, liquid refrigerant flow into compressor which could damage the compressor in cooling mode. Also condensing might happened for unclosed EEV's Indoor unit due to flow of refrigerant.

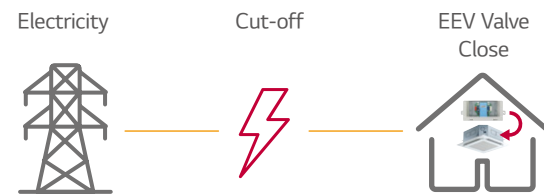

How to Install

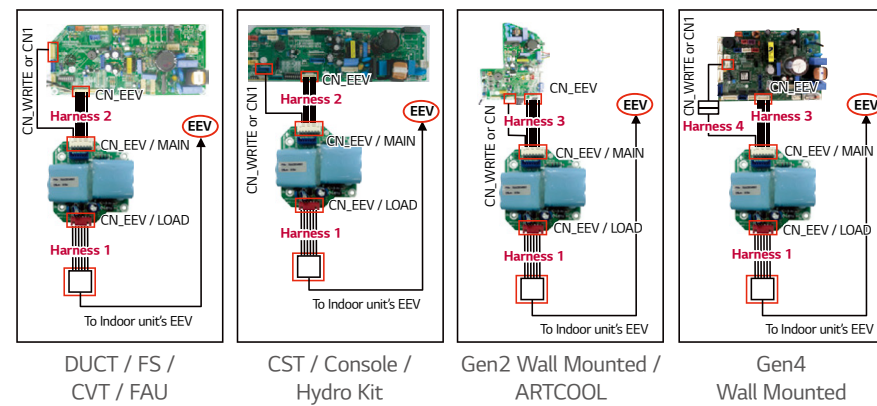

- ① Turn the power off using circuit breaker.
- ② Disconnect the EEV cable of the indoor unit's PCB (CN-EEV)
- ③ Connect the independent power module (CN-EEV/LOAD) to the indoor unit's EEV, using harness 1.
- ④ Connect the independent power module (CN-EEV/MAIN) to the indoor unit's PCB (CN-EEV/CN-WRITE), using harness 2 or 3.
- ⑤ Supply the power.

* FS : Floor Standing
* CVT : Convertible
* FAU : Fresh Air Intake Unit
* CST : Cassette

AUXILIARY HEATER RELAY KIT

Providing an efficient way to add auxiliary heat



Model Name

PRARS1

Applied Products

Wall Mounted, Art Cool Mirror, Art Cool Gallery

Model Name

PRARH1

Applied Products

1,2,4 Way Ceiling Cassette, High Static Ducted, Low Static Ducted, Ceiling Suspended

Key Features

- Provides two stages of auxiliary heat for indoor unit
- Provides ability to use the two stage auxiliary heater as the primary or secondary heating source

Included Parts

Model	PRARH1			
Item	Auxiliary Heater Relay Kit	Screw	Insulation	Installation Manual
Q'ty	1	2	2	1
Figure				

Model	PRARS1			
Item	Auxiliary Heater Relay Kit	Screw	Insulation	Installation Manual
Q'ty	1	2	2	1
Figure				

Key Application

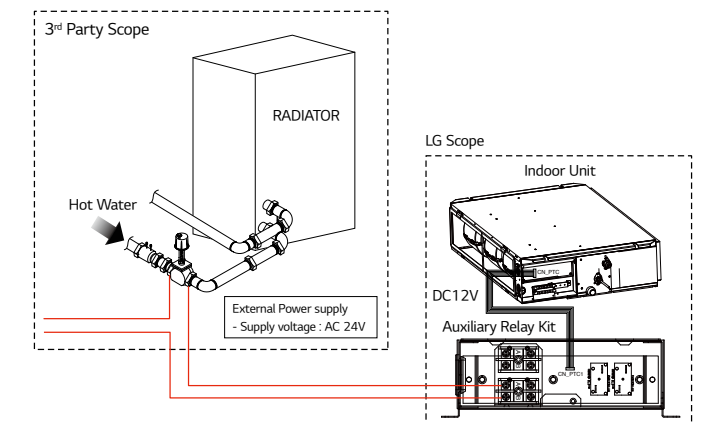

How to Install

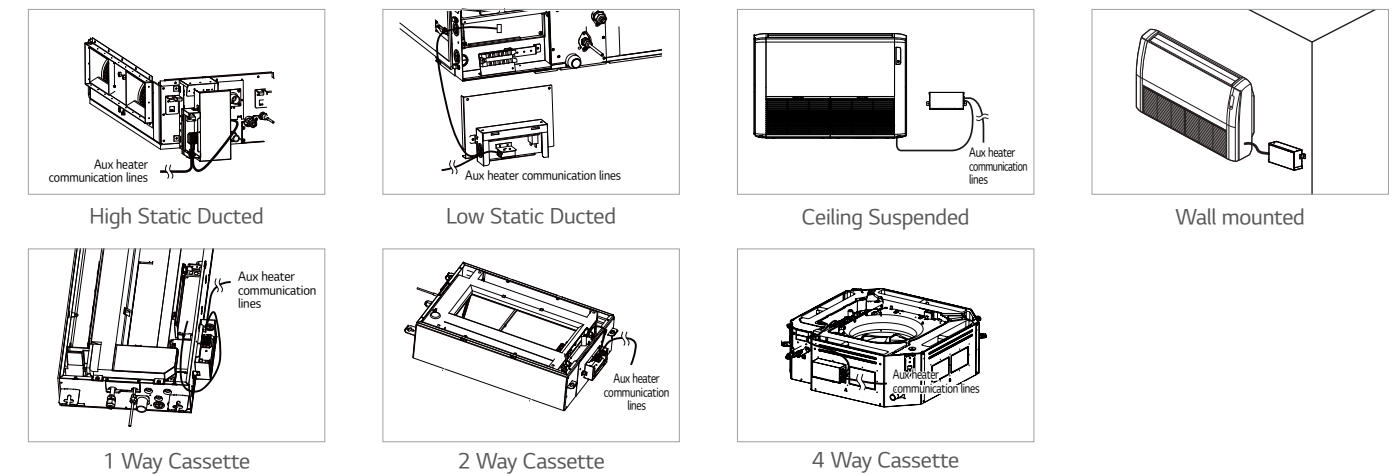

HEAT RECOVERY UNIT

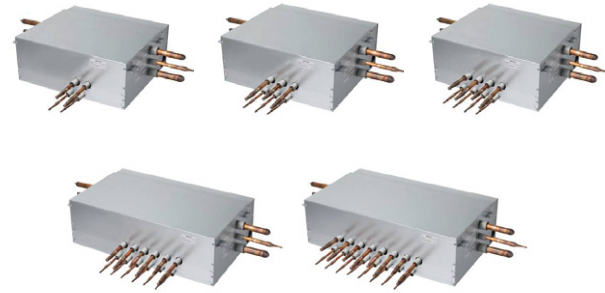

Model Name

PRHR023 (2 Branch Unit)
 PRHR033 (3 Branch Unit)
 PRHR043 (4 Branch Unit)
 PRHR063 (6 Branch Unit)
 PRHR083 (8 Branch Unit)

Applied Products

Multi V 5
 Multi V IV
 Multi V Water IV

Key Features

- Max. 64 indoor units can be connected (Max. 8 indoor units per branch)
- It is easy to install due to the automatic search algorithm for piping detection
- Subcooling cycle in HR unit makes the system efficiency maximum

Connection Capacity

Maximum number of connectable indoor units :
 64 IDUs/HR unit (in case of 8 ports model)

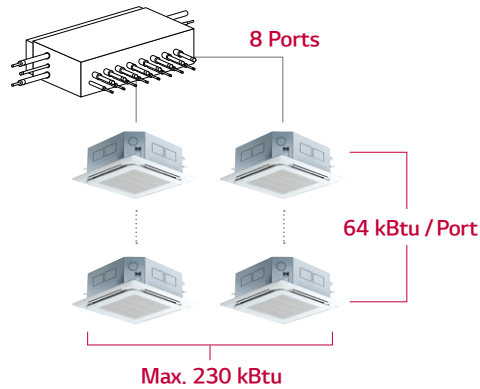

Flexible Connection

Series connection can be installed without pipes crossing.

New



Considering the direction for Indoor units and SVC port, connection for reverse direction makes much easier

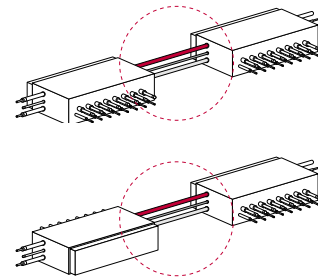

Reduce Noise

Heating → Cooling switching operation

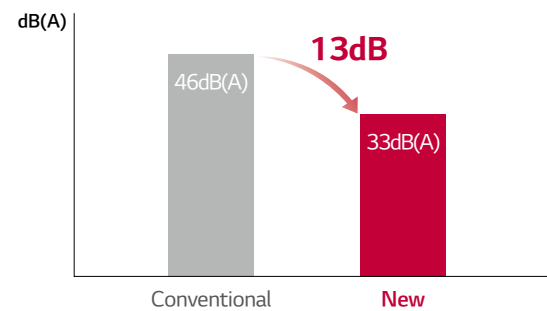

Test Condition (ISO Standard)

- Temp. : (Cooling) 27°C DB / 19°C WB, 35°C DB / 24°C WB
 (Heating) 20°C DB / 15°C WB, 7°C DB / 6°C WB
- Operating : Cooling → Heating switching operation

Included Parts

- HR unit (1EA)
- Hanging bolts M10 or M8 (4EA)
- Nut M8 or M10 (8EA)
- Washers M10 (8EA)
- Reducers

Specification

Model		PRHR023	PRHR033	PRHR043	PRHR063	PRHR083	
Number of Branch	EA	2	3	4	6	8	
Maximum Connectable Capacity of Indoor Units (Per branch / unit)	kW	17.5/35	17.5/52.5	17.5/69.5	17.5/69.5	17.5/69.5	
Maximum Number of Connectable Indoor units per Branch	EA	8	8	8	8	8	
Nominal Input	Cooling	kW	0.040	0.040	0.076	0.076	
	Heating	kW	0.038	0.038	0.072	0.072	
Net. Weight	kg	18.5	20.3	22.0	28.3	31.8	
Dimensions (W x H x D)	mm	786 x 218 x 657	786 x 218 x 657	786 x 218 x 657	1,113 x 218 x 657	1,113 x 218 x 657	
Piping connections	Indoor Unit	Liquid	mm (inch)	9.52 (3/8)	9.52 (3/8)	9.52 (3/8)	9.52 (3/8)
		Gas	mm (inch)	15.88 (5/8)	15.88 (5/8)	15.88 (5/8)	15.88 (5/8)
	Outdoor Unit	Low pressure	mm (inch)	22.2 (7/8)	28.58 (11/8)	28.58 (11/8)	28.58 (11/8)
		High Pressure	mm (inch)	19.05 (3/4)	22.2 (7/8)	22.2 (7/8)	22.2 (7/8)
Power supply	Ø / V / Hz	1 / 220-240 / 50 1 / 220 / 60	1 / 220-240 / 50 1 / 220 / 60	1 / 220-240 / 50 1 / 220 / 60	1 / 220-240 / 50 1 / 220 / 60	1 / 220-240 / 50 1 / 220 / 60	

Reducers for Indoor Unit and HR Unit

Model	Liquid	High Pressure	Low Pressure
Indoor unit reducer			
PRHR023			
HR unit reducer			

Y BRANCH AND HEADERBRANCH

For refrigerant distribution of indoor units



Model Name

Refer to specifications

Applied Products

- Multi V 5
- Multi V IV
- Multi V III, Multi V Plus II, Multi V Plus
- Multi V S
- Multi V Water IV
- Multi V Water II

Key Features

- Various Y Branch pipe of different capacities make Multi V installation much easier
- Y Branch and header branch for both gas and liquid are provided.
- Insulation material is also provided for covering the branches

Key Application

Heat Pump System

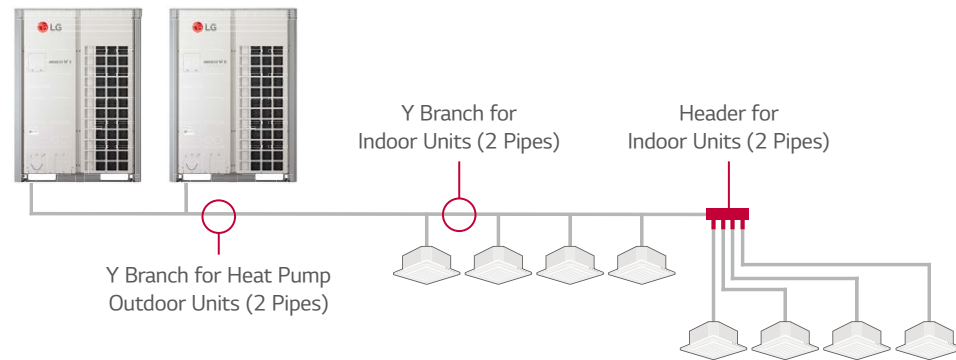

Heat Recovery System

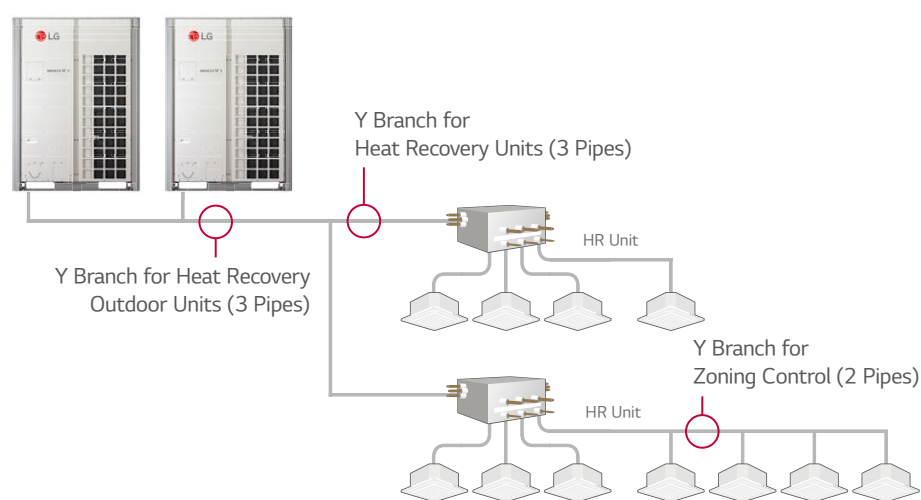

Specification

Header Branch

R410A

(Unit : mm)

Model	Gas Pipe	Liquid Pipe
ARBL054 (4 Branch)		
ARBL057 (7 Branch)		
ARBL104 (4 Branch)		
ARBL107 (7 Branch)		
ARBL1010 (10 Branch)		
ARBL2010 (10 Branch)		

PIPING ACCESSORIES

Y Branch pipe for connection of outdoor units

Specification

Heat Pump

R410A

Multi V 5, Multi V IV, Multi V III, Multi V Water IV, Multi V Water II

(Unit : mm)

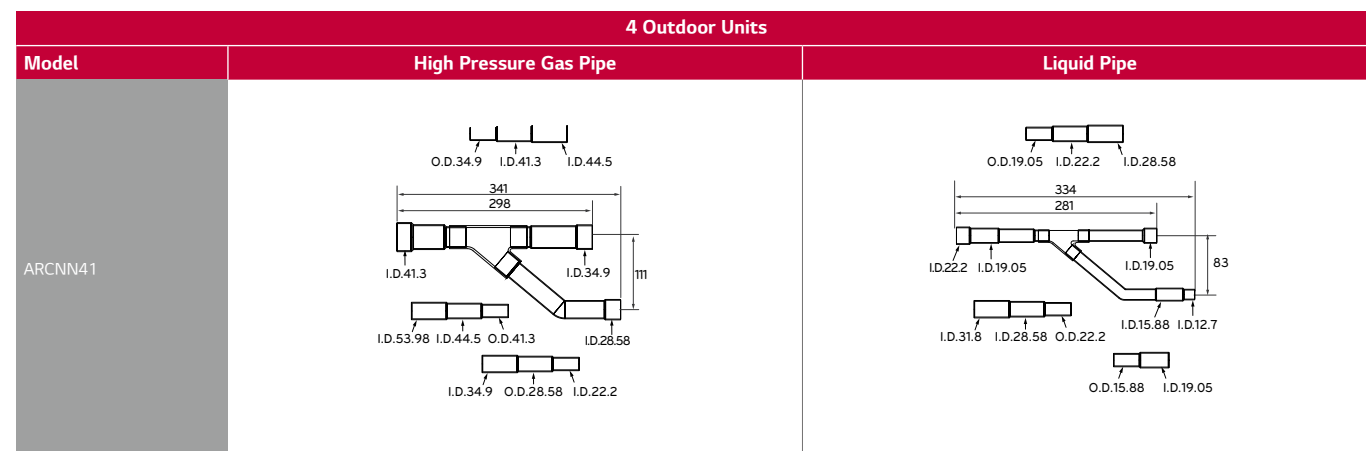
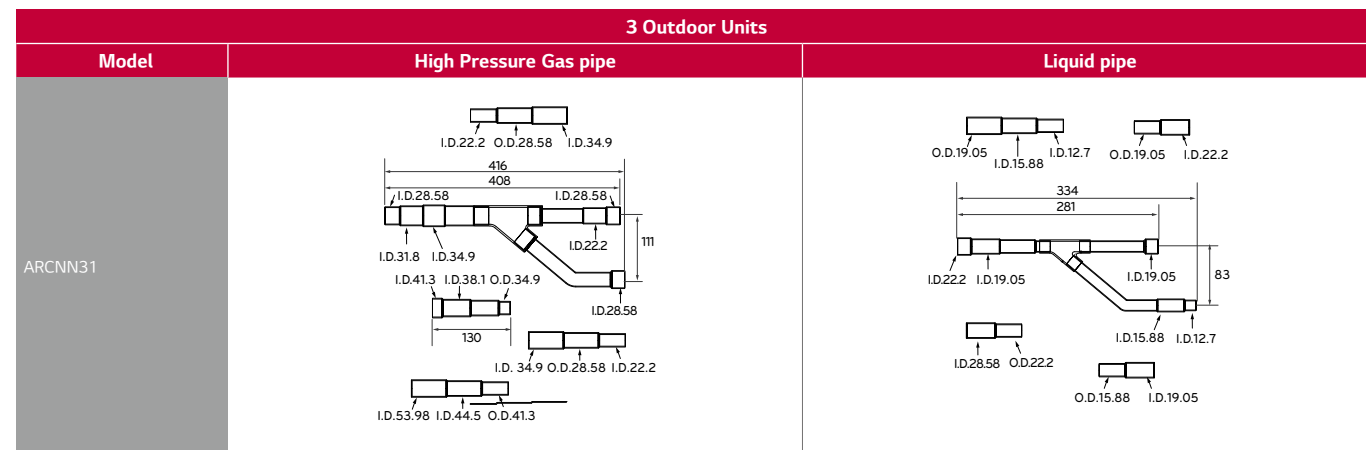
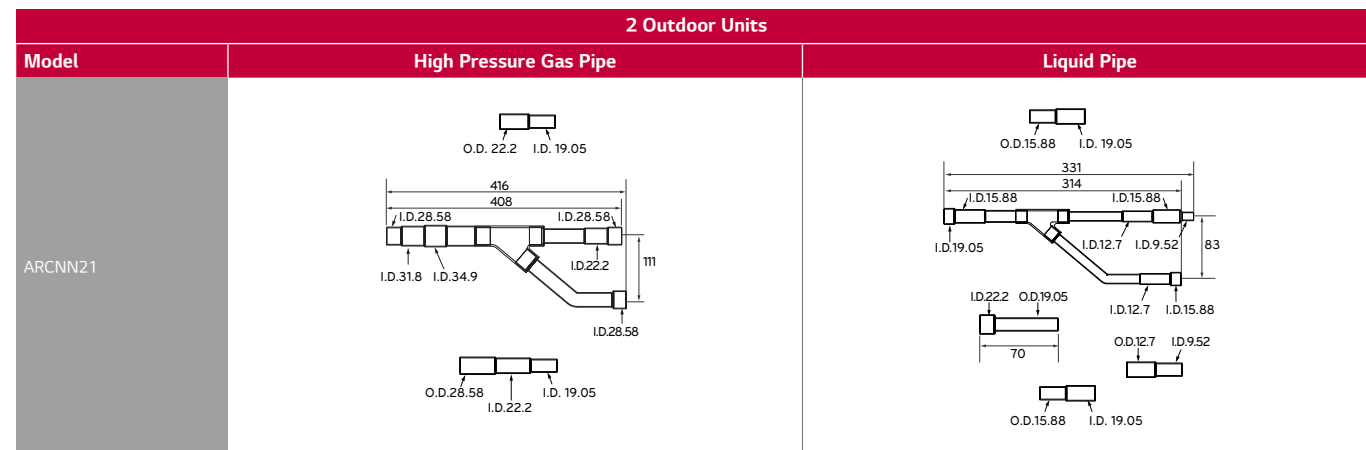

Specification

Heat Recovery

R410A

Multi V 5, Multi V IV Heat Recovery, Multi V III Heat Recovery, Multi V Water IV Heat Recovery, Multi V Water II Heat Recovery

(Unit : mm)

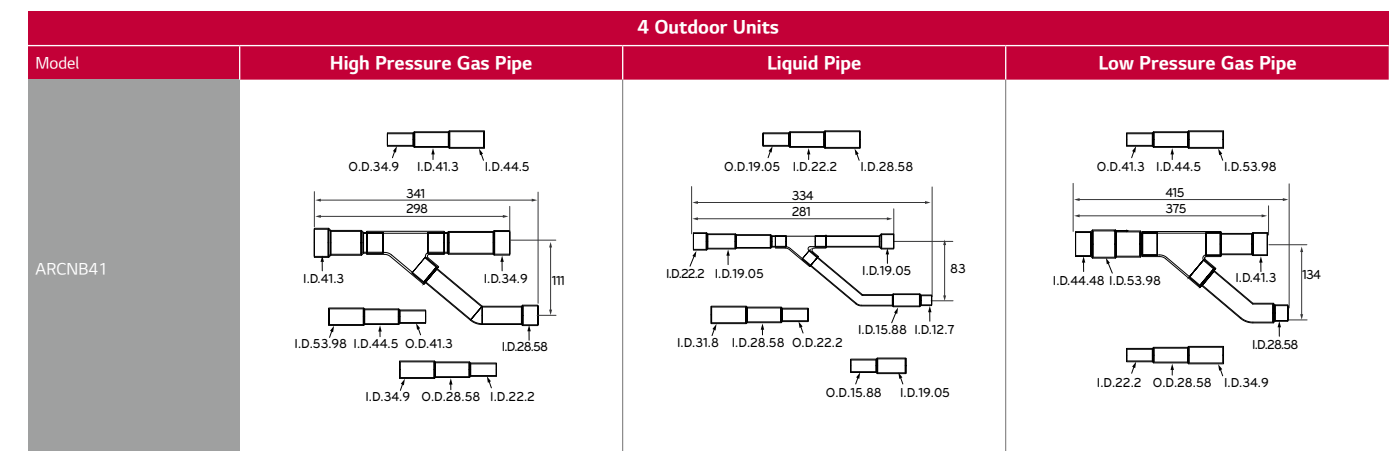
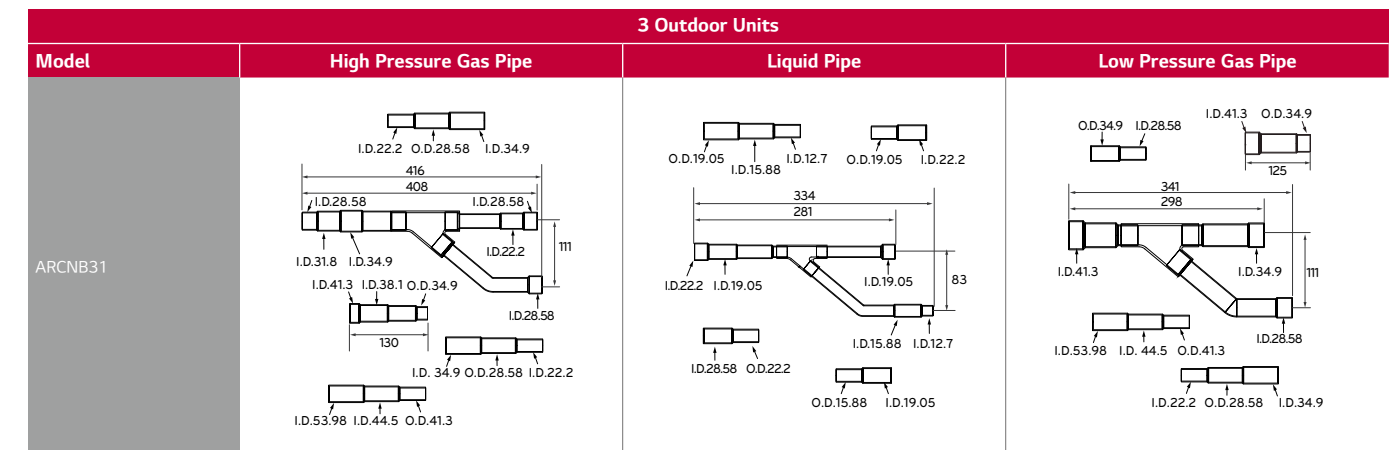
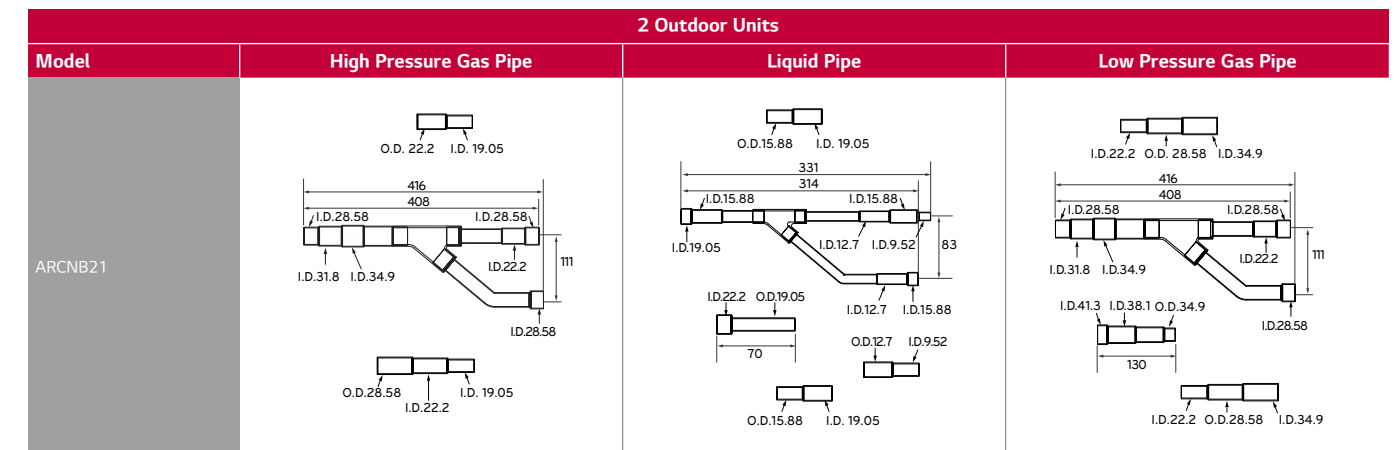

PIPING ACCESSORIES

Y Branch pipe for connection of outdoor units

Specification

Heat Pump, Heat Recovery Zone Control

R410A Multi V 5, Multi V IV, Multi V III, Multi V Plus II, Multi V Plus, Multi V S, Multi V Mini, Multi V Space II, Multi V Water IV, Multi V Water S, Multi V Water II

(Unit : mm)

Model	Gas Pipe	Liquid Pipe
ARBLN01621		
ARBLN03321		

Model	Gas Pipe	Liquid Pipe
ARBLN07121		
ARBLN14521		

Model	Gas Pipe	Liquid Pipe
ARBLN23220		

Specification

Heat Recovery

R410A Multi V 5, Multi V IV Heat Recovery, Multi V III Heat Recovery, Multi V Water IV Heat Recovery, Multi V Water II Heat Recovery

(Unit : mm)

Model	High Pressure Gas Pipe	Liquid Pipe	Low Pressure Gas Pipe
ARBLB01621			
ARBLB03321			
ARBLB07121			
ARBLB14521			
ARBLB23220			

REFRIGERANT CHARGING KIT

Recharging refrigerant after a pump down or when refrigerant is either insufficient or excessive

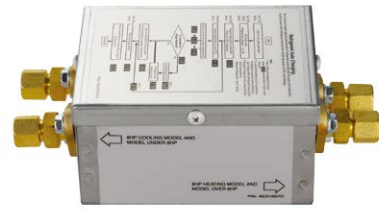

Model Name

PRAC1

Applied Products

- Multi V 5
- Multi V IV Heat Pump
- Multi V IV Heat Recovery
- Multi V III Heat Pump
- Multi V III Heat Recovery
- Multi V Plus II
- Multi V Sync II

How to use

- Arrange manifold, capillary assembly, refrigerant vessel and scale
- Connect manifold to the gas pipe service valve of outdoor unit as shown in the figure
- Connect manifold and capillary tube. Use designated capillary assembly only.
If designated capillary assembly isn't used, the system may get damaged
- Connect capillary and refrigerant vessel
- Purge hose and manifold
- After "568" is displayed, open the valve and charge the refrigerant

Key Application

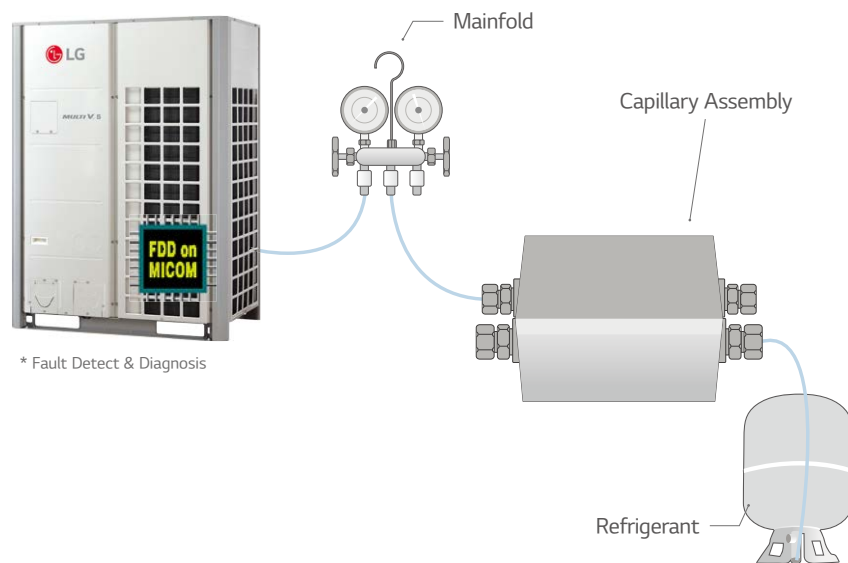

DRAIN HOSE

Easy drain installation

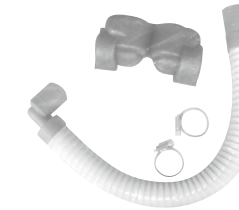

Model Name

- PHDHA05T
- PHDHA07T
- PHDHA05B
- PHDHA07B

Applied Products

Multi V Indoor units

Key Features

- It reduces the installation time by over 40% with elbow-less drain hose
- Drain pump covers maximum 700mm high, featuring easy piping installation

Key Application

- Ceiling Mounted Cassette and Ceiling Concealed Duct (refer to PDB for applicable model)

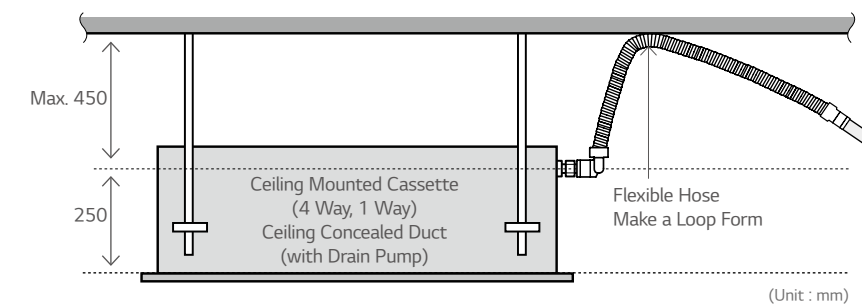

Specification

Model	Length	Quantity
PHDHA05T	500mm	30EA
PHDHA07T	700mm	30EA
PHDHA05B	500mm	5EA
PHDHA07B	700mm	5EA

STOPPER VALVES



Model Name

PRVT120 (Under 12.7mm)
 PMVT780 (Under 22.2mm)
 PMVT980 (Under 28.58mm)

Key Features

- This unit can be applied for the additional indoor unit's installation
- This unit can be applied for each indoor unit's service

Specification

Model	Specification
PRVT120	
PRVT780	
PRVT980	

How to Install

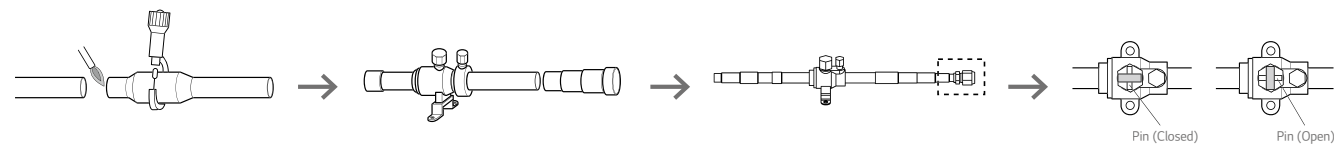

1. Cut the inlet side of the connector, and weld the pipe
2. If installing additional indoor units, the outlet side connector should be cut according to installation pipe.
3. When installing a stopper valve, the flare part should be facing towards additional indoor unit.
4. When installing an additional indoor unit, the SVC valve should be in closed state.

* When welding, service valve should be wrapped by wet cloth.

Application

(Room 3 & 4 : in use / Room 1 & 2 : need to install indoor units)

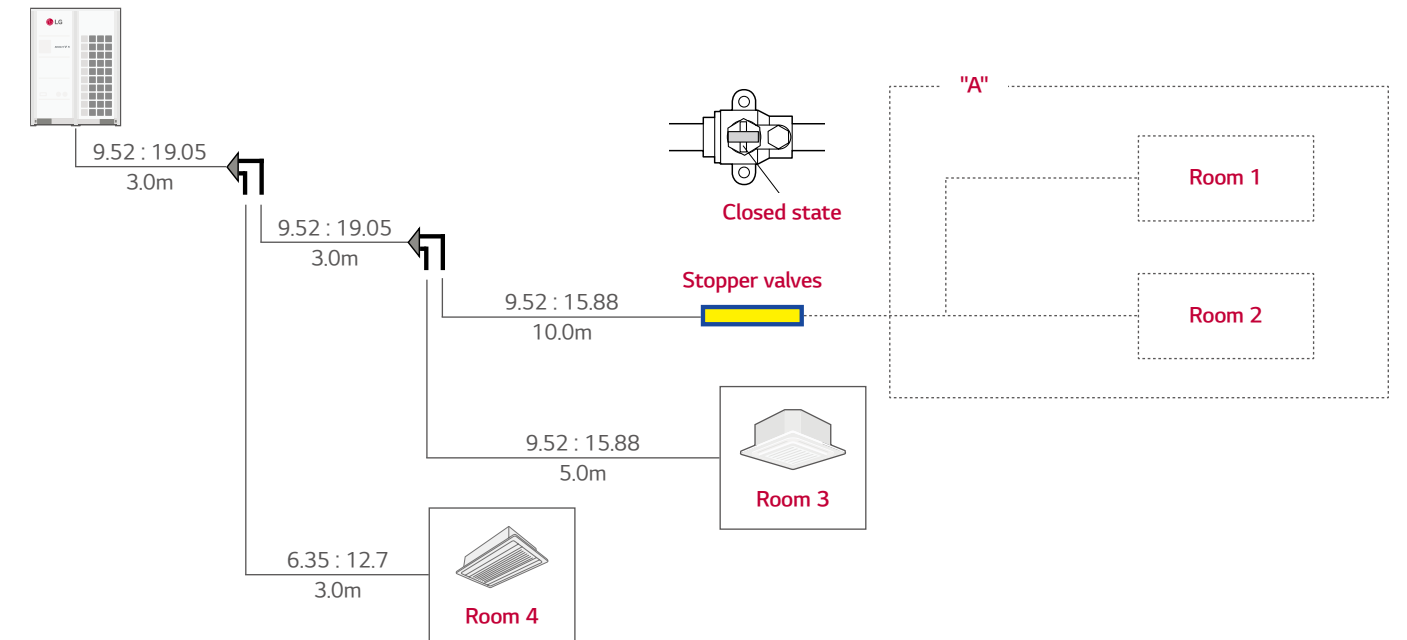

- In case of installation of additional indoor unit, refrigerant of used indoor unit must be discharged. (Room 3 & Room 4)
- If stopper valve is already installed, you can install additional indoor unit without refrigerant loss from the entire system.
- After installation of additional indoor unit, you just need refrigerant charging for "A" section.
- Then, open the Stopper Valve.

